

PHYSICS

Q.1 Force acting on a particle is $(2\hat{i} + 3\hat{j})$ N.

Work done by this force is zero, when a particle is moved on the line $3y + kx = 5$. Here value of k is -

- (A) 2 (B) 4 (C) 6 (D) 8

[A]

Sol. Force is parallel to a line $y = \frac{3}{2}x + c$

The equation of given line can be written as

$$y = -\frac{k}{3}x + \frac{5}{3}$$

Work done will be zero, when force is perpendicular to the displacement i.e., the above two lines are perpendicular or $m_1 m_2 = -1$

$$\text{or } \left(\frac{3}{2}\right) \left(-\frac{k}{3}\right) = -1$$

or $k = 2$

Q.2 boat travels upstream in a river and at $t = 0$ a wooden cork is thrown over the side with zero initial velocity. After 7.5 minutes the boat turns and starts moving downstream catches the cork when it has drifted 1 km downstream. Then the velocity of water current is -

- (A) 2 Km/hr (B) 4 Km/hr
(C) 6 Km/hr (D) 8 Km/h

Sol. [B] Assume observer standing on water of flowing river.

$$\text{Then, } V_r = \frac{d}{t} = 4 \text{ km/hr}$$

Q.3 Two vectors \vec{a} and \vec{b} lie in one plane. Vector

\vec{c} lies in different plane, then $\vec{a} + \vec{b} + \vec{c}$

- (A) may be zero
(B) must be zero
(C) must not be zero
(D) All of above are possible

Sol. [C]

sum of three non coplanar vectors can not be zero

Q.4 A man crosses the river perpendicular to river flow in time t seconds and travels an equal distance down the stream in T seconds. The ratio of man's speed in still water to the speed of river water will be :

- (A) $\frac{t^2 - T^2}{t^2 + T^2}$ (B) $\frac{T^2 - t^2}{T^2 + t^2}$
(C) $\frac{t^2 + T^2}{t^2 - T^2}$ (D) $\frac{T^2 + t^2}{T^2 - t^2}$

Sol. [C] Let velocity of man in still water be v and that of water with respect to ground be u .

Velocity of man perpendicular to river flow with respect to ground = $\sqrt{v^2 - u^2}$

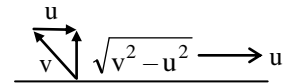

Velocity of man downstream = $v + u$

As given. $\sqrt{v^2 - u^2} t = (v + u)T$

$$\Rightarrow (v^2 - u^2)t^2 = (v + u)^2 T^2$$

$$\Rightarrow (v - u)t^2 = (v + u)T^2$$

$$\therefore \frac{v}{u} = \frac{t^2 + T^2}{t^2 - T^2}$$

Q.5 If \vec{a}_1 and \vec{a}_2 are two non collinear unit vectors

and if $|\vec{a}_1 + \vec{a}_2| = \sqrt{3}$, then the value of

$(\vec{a}_1 - \vec{a}_2) \cdot (2\vec{a}_1 + \vec{a}_2)$ is -

- (A) 2 (B) $\frac{3}{2}$ (C) $\frac{1}{2}$ (D) 1

Sol. [C]

$a_1 = a_2 = 1$ and

$$a_1^2 + a_2^2 + 2a_1 a_2 \cos\theta = (\sqrt{3})^2 = 3$$

$$\text{Or } 1 + 1 + 2\cos\theta = 3 \quad \text{or } \cos\theta = \frac{1}{2}$$

$$\text{Now } (\vec{a}_1 - \vec{a}_2) \cdot (2\vec{a}_1 + \vec{a}_2) = 2a_1^2 - a_2^2 - a_1 a_2 \cos\theta$$

$$= 2 - 1 - \frac{1}{2} = \frac{1}{2}$$

Q.6 If \vec{a} and \vec{b} are two unit vectors and $\vec{R} = \vec{a} + \vec{b}$

and also if $|\vec{R}| = R$, then -

- (A) $R < 0$
- (B) $R > 2$
- (C) $0 \leq R \leq 2$
- (D) R must be 2

Sol. [C]

if $|\vec{R}| = |\vec{a} + \vec{b}|$ then, $(a - b) \leq R \leq (a + b)$

Q.7 Two forces \vec{F}_1 and \vec{F}_2 are acting on a particle.

Magnitude of resultant of these force is $|\vec{F}_1|$.

Then :

- (i) $|\vec{F}_2|$ may be zero.
- (ii) $|\vec{F}_2|$ may not be zero.

Select correct one -

- (A) Only (i) is correct
- (B) Only (ii) is correct
- (C) Both (i) and (ii) will be correct
- (D) Neither (i) nor (ii) will be correct

[C]

Sol. If $|\vec{F}_1| = |\vec{F}_2|$ and angle between these two

forces is 120° then resultant is equal $|\vec{F}_1|$ or $|\vec{F}_2|$.

Q.8 A conveyor belt of width 10 m is moving along x-axis with speed 4 m/s as shown in the figure. Two points A and B are situated on the conveyor belt. A person want to move from A to B in least time. His speed with respect to belt is 2 m/s. The time taken by the person is

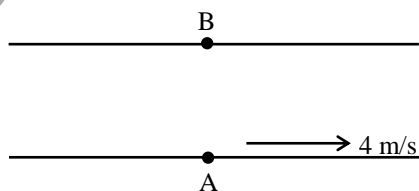

- (A) 2.5 s
- (B) 5 s

- (C) 4 s
- (D) 3 s

[B]

Sol.

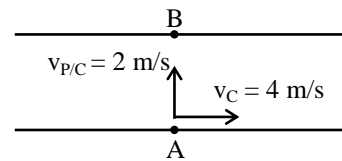

$$t_{\min} = \frac{AB}{v_{P/C}} = \frac{10}{2} = 5 \text{ s}$$

Q.9 There are two vectors $\vec{A} = 2\hat{i} + \hat{j} + \hat{k}$ and

$\vec{B} = \hat{i} + 2\hat{j} - 2\hat{k}$, then vector component of

\vec{A} along \vec{B} is -

- (A) $\frac{2\hat{i} + 2\hat{j} - 2\hat{k}}{9}$
- (B) $\frac{2}{3} (2\hat{i} + \hat{j} + \hat{k})$

- (C) $\frac{2}{3} (\hat{i} + 2\hat{j} - 2\hat{k})$
- (D) None of these

[A]

Sol. Component of \vec{A} along $\vec{B} = \frac{\vec{A} \cdot \vec{B}}{|\vec{B}|} \cdot \hat{B}$

Q.10 A billiards-ball is at point A on a billiards-table whose dimensions are given in fig. At what angle should the ball be struck so that it should rebound from two cushions and go into pocket B? Assume that in striking the cushion, the ball's direction of motion changes according to the law of reflection of light from a mirror, i.e., the angle of reflection equals the angle of incidence.

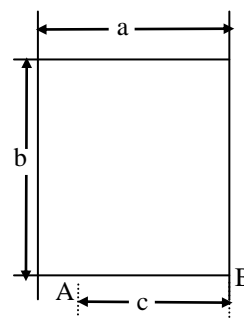

- (A) $\frac{a-2c}{b}$ (B) $\frac{2a-c}{b}$
 (C) $\frac{2a-c}{2b}$ (D) $\frac{a}{b} - \frac{a}{2c}$

[C]

Sol. Let us resolve the velocity v imparted to the ball into component parallel with the sides of the table and consider the path of a ball as shown, for example, in the diagram (fig.).

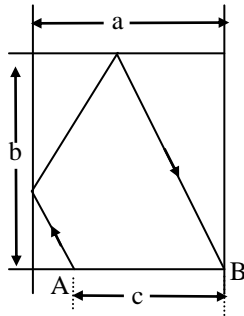

We obtain two equations, evident from the diagram :

$$\frac{2a-c}{t} = v \cos \alpha, \quad \frac{2b}{t} = v \sin \alpha,$$

From these equations we get :

$$\cot \alpha = \frac{2a-c}{2b},$$

i.e., we find angle α , at which the ball must be struck. The value for the velocity v which is imparted to the ball plays no part at all.

Q.11 A man is moving with constant velocity $v_2 = 20\text{m/s}$ in horizontal plane. At what angle to the horizontal should the man hold his umbrella so that he can protect himself from rain falling vertically with velocity 60m/sec .

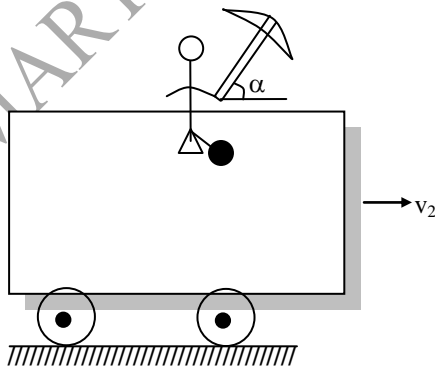

- (A) $\sin^{-1} 3$ (B) $\tan^{-1} 3$

- (C) $\cos^{-1} 3$ (D) $\tan^{-1} \frac{1}{\sqrt{3}}$

[B]

Sol. Man should hold the umbrella in direction in which rain appears to come i.e., \vec{v}_{rm}
 $\vec{v}_{rm} = \vec{v}_r - \vec{v}_m$; $v_{rm} \rightarrow$ Velocity of rain with respect to man.

$$\vec{v}_r = \vec{v}_{rm} + \vec{v}_m$$

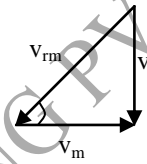

$$\tan \alpha = \frac{v_r}{v_m} = \frac{60}{20} = 3$$

$$\alpha = \tan^{-1} 3$$

Q.12 For the vectors \vec{a} and \vec{b} shown in figure,

$$\vec{a} = \sqrt{3} \hat{i} + \hat{j} \text{ and } |\vec{b}| = 10 \text{ units while } \theta =$$

23° , then the value of $R = |\vec{a} + \vec{b}|$ is nearly

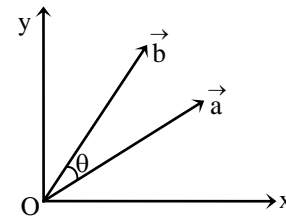

- (A) 12 (B) 13
 (C) 14 (D) 15

[A]

Sol.

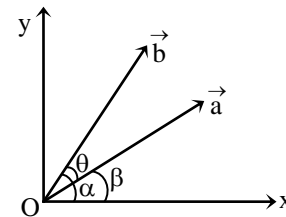

$$\tan \beta = \frac{1}{\sqrt{3}}$$

$$\Rightarrow \beta = 30^\circ$$

$$\therefore \alpha = \theta + \beta = 53^\circ$$

$$\therefore \vec{b} = 10 \cos 53^\circ \hat{i} + 10 \sin 53^\circ \hat{j} = 6\hat{i} + 8\hat{j}$$

$$\therefore \vec{a} + \vec{b} = (6 + \sqrt{3})\hat{i} + 9\hat{j}$$

Q.13 The sum, difference and cross product of two vectors \vec{A} and \vec{B} are mutually perpendicular if:

- (A) \vec{A} and \vec{B} are perpendicular to each other and $|\vec{A}| = |\vec{B}|$
- (B) \vec{A} and \vec{B} are perpendicular to each other
- (C) \vec{A} and \vec{B} are perpendicular but their magnitudes are arbitrary
- (D) $|\vec{A}| = |\vec{B}|$ and their directions are arbitrary

[D]

Sol. Let $\vec{A} = a_1\hat{i} + a_2\hat{j} + a_3\hat{k}$ and $\vec{B} = b_1\hat{i} + b_2\hat{j} + b_3\hat{k}$

Given that $\vec{A} + \vec{B}$ is perpendicular to $\vec{A} - \vec{B}$

$$\text{i.e., } (\vec{A} + \vec{B}) \cdot (\vec{A} - \vec{B}) = 0$$

$$\text{or } (a_1 + b_1)(a_1 - b_1) + (a_2 + b_2)(a_2 - b_2) + (a_3 + b_3)(a_3 - b_3) = 0$$

$$\text{or } a_1^2 + a_2^2 + a_3^2 = b_1^2 + b_2^2 + b_3^2$$

$$\text{or } |\vec{A}| = |\vec{B}|$$

cross product of \vec{A} and \vec{B} is perpendicular to the plane formed by \vec{A} and \vec{B} or $\vec{A} + \vec{B}$ and $\vec{A} - \vec{B}$.

Q.14 A particle moves in x-y plane. The position vector of particle at any time t is $\vec{r} = \{(2t)\hat{i} + (2t^2)\hat{j}\}$ m. The rate of change of θ at time t = 2 s. (where θ is the angle which its velocity vector makes with positive x-axis) is:

- (A) $\frac{2}{17}$ rad/s (B) $\frac{1}{14}$ rad/s

- (C) $\frac{4}{7}$ rad/s (D) $\frac{6}{5}$ rad/s

[A]

Sol. $x = 2t \Rightarrow v_x = \frac{dx}{dt} = 2$

$$y = 2t^2 \Rightarrow v_y = \frac{dy}{dt} = 4t$$

$$\therefore \tan \theta = \frac{v_y}{v_x} = \frac{4t}{2} = 2t$$

Differentiating with respect to time we get,

$$(\sec^2 \theta) \frac{d\theta}{dt} = 2$$

$$\text{or } (1 + \tan^2 \theta) \frac{d\theta}{dt} = 2$$

$$\text{or } (1 + 4t^2) \frac{d\theta}{dt} = 2$$

$$\text{or } \frac{d\theta}{dt} = \frac{2}{1 + 4t^2}$$

$$\frac{d\theta}{dt} \text{ at } t = 2 \text{ s is } \frac{d\theta}{dt} = \frac{2}{1 + 4(2)^2} = \frac{2}{17} \text{ rad/s}$$

Q.15 A 2 m wide truck is moving with a uniform speed $v_0 = 8$ m/s along a straight horizontal road. A pedestrian starts to cross the road with a uniform speed v when the truck is 4 m away from him. The minimum value of v so that he can cross the road safely is -

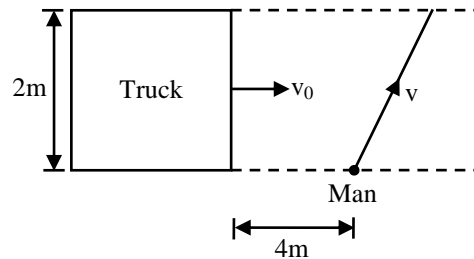

- (A) 2.62 m/s (B) 4.6 m/s
- (C) 3.57 m/s (D) 1.414 m/s

[C]

Sol. Let the man starts crossing the road at an angle θ as shown in figure. For safe crossing the condition is that the man must cross the road by the time the truck describes the distance $4 + AC$ or $4 + 2 \cot \theta$.

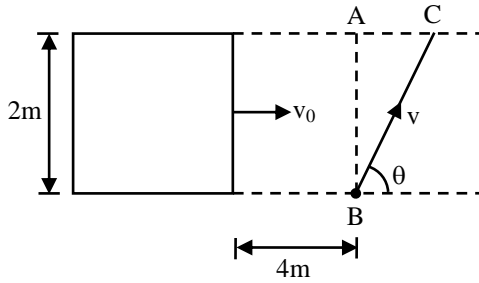

$$\therefore \frac{4 + 2 \cot \theta}{8} = \frac{2 / \sin \theta}{v}$$

$$\text{or } v = \frac{8}{2 \sin \theta + \cos \theta} \quad \dots (1)$$

For minimum v , $\frac{dv}{d\theta} = 0$

$$\text{or } \frac{-8(2 \cos \theta - \sin \theta)}{(2 \sin \theta + \cos \theta)^2} = 0$$

$$\text{or } 2 \cos \theta - \sin \theta = 0$$

$$\text{or } \tan \theta = 2$$

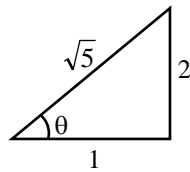

$$\text{From Eq. (1) } v_{\min} = \frac{8}{2 \left(\frac{2}{\sqrt{5}} \right) + \frac{1}{\sqrt{5}}} = \frac{8}{\sqrt{5}}$$

3.57 m/s

Q.16 A smooth square platform ABCD is moving towards right with a uniform speed v . At what angle θ must a particle be projected from A with speed u so that it strikes the point B –

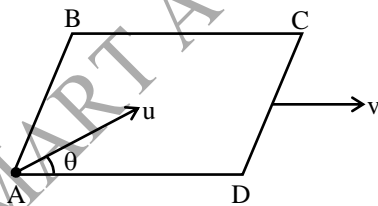

- (A) $\sin^{-1} \left(\frac{u}{v} \right)$ (B) $\cos^{-1} \left(\frac{v}{u} \right)$
 (C) $\cos^{-1} \left(\frac{u}{v} \right)$ (D) $\sin^{-1} \left(\frac{v}{u} \right)$

[B]

Sol. Particle will strike the point B if velocity of particle with respect to platform is along AB

or component of its relative velocity along AD is zero i.e.,

$$u \cos \theta = v$$

$$\text{or } \theta = \cos^{-1} \left(\frac{v}{u} \right)$$

Q.17 The vectors from origin to the points A

and B are $\vec{A} = 3\hat{i} - 6\hat{j} + 2\hat{k}$ and

$$\vec{B} = 2\hat{i} + \hat{j} - 2\hat{k}$$

respectively. The area of the triangle OAB will be -

(A) $\frac{5}{2} \sqrt{17}$ sq. unit (B) $\frac{2}{5} \sqrt{17}$ sq. unit

(C) $\frac{3}{5} \sqrt{17}$ sq. unit (D) $\frac{5}{3} \sqrt{17}$ sq. unit

3.[A] Area of $\Delta = \frac{1}{2} \left| \vec{OA} \times \vec{OB} \right|$

$$= \frac{1}{2} \begin{vmatrix} \hat{i} & \hat{j} & \hat{k} \\ 3 & -6 & 2 \\ 2 & 1 & -2 \end{vmatrix}$$

$$= \frac{1}{2} \left| (10\hat{i} + 10\hat{j} + 15\hat{k}) \right| = \frac{1}{2} \sqrt{425} = \frac{5}{2} \sqrt{17}$$

Q.18 The force $(3\hat{i} - \hat{j} + \hat{k})$ N displaces a body from (1, 2, 0) to (3, 4, 5). Coordinates are in metre. The work done is -

- (A) 9 J (B) 18 J
 (C) 11 J (D) 29 J

[A]

Sol. $\vec{F} = 3\hat{i} - \hat{j} + \hat{k}$

$$\vec{s} = 2\hat{i} + 2\hat{j} + 5\hat{k}$$

$$W = 6 - 2 + 5 = 9 \text{ J}$$

Q.19 12 forces, each equal to P, act on a body. If each force makes an angle of 30° with the next one, the resultant of all the forces is -

- (A) zero (B) 3 P
 (C) 6 P (D) 12 P

[A]

Sol. $N = 12, \theta = \frac{2\pi}{12} = 30^\circ$

Resultant force = 0

Q.20 A force of 6 kgf and another of 8 kgf can be applied to produce the effect of a single force equal to -

- (A) 16 kgf (B) 1 kgf
(C) 10 kgf (D) 0 kgf

[C]

Sol. 10 kgf

Q.30 The resultant of two vectors \vec{P} and \vec{Q} is \vec{R} . If the magnitude of \vec{Q} is doubled, the new resultant becomes perpendicular to \vec{P} , then the magnitude of \vec{R} is -

- (A) $\frac{P^2 - Q}{2PQ}$ (B) $\frac{P + Q}{P - Q}$
(C) Q (D) $\frac{P}{Q}$

[C]

Sol. $R = \sqrt{P^2 + 2PQ\cos\theta + Q^2}$... (1)

$$\tan 90^\circ = \frac{2Q\sin\theta}{P + 2Q\cos\theta} = \frac{1}{0}$$

$$P + 2Q\cos\theta = 0$$

from (1)

$$R = \sqrt{P(P + 2Q\cos\theta) + Q^2}$$

$$R = Q$$

Q.31 Given : $\vec{P} = \vec{A} - \vec{B}$ and $P = A + B$. The angle between \vec{A} and \vec{B} is -

- (A) 0° (B) 90°
(C) 180° (D) 270°

[C]

Sol. $(A + B) = \sqrt{A^2 + B^2 - 2AB\cos\theta}$

$$A^2 + B^2 + 2AB = A^2 + B^2 - 2AB\cos\theta$$

$$2AB(1 + \cos\theta) = 0$$

$$\cos\theta = -1$$

$$\theta = 180^\circ$$

Q.32 If $\vec{A} = \hat{i} + 2\hat{j} + 2\hat{k}$ and $\vec{B} = 3\hat{i} + 6\hat{j} + 2\hat{k}$, then the vector in the direction of \vec{A} and having same magnitude as $|\vec{B}|$, is -

- (A) $\frac{7}{3}(\hat{i} + 2\hat{j} + 2\hat{k})$ (B) $7(\hat{i} + 2\hat{j} + 2\hat{k})$
(C) $\frac{3}{7}(\hat{i} + 2\hat{j} + 2\hat{k})$ (D) $\frac{7}{9}(\hat{i} + 2\hat{j} + 2\hat{k})$

[A]

Sol. Vector in the direction of \vec{A} and having same magnitude as B is = $B\hat{A}$

$$= B \left(\frac{\vec{A}}{A} \right)$$

$$= \frac{7}{3}(\hat{i} + 2\hat{j} + 2\hat{k})$$

Q.33 Two forces of magnitudes F and $\sqrt{3}F$ act at right angles to each other. Their resultant makes an angle β with F. The value of β is -

- (A) 30° (B) 45°
(C) 60° (D) 135°

[C]

Sol. $\tan\beta = \frac{B\sin\theta}{A + B\cos\theta}$

$$= \frac{F\sqrt{3}\sin\theta}{F + F\sqrt{3}\cos\theta}$$

$$= \frac{\sqrt{3}\sin\theta}{1 + \sqrt{3}\cos\theta}$$

$$\tan\beta = \frac{\sqrt{3}}{1} \quad (\theta = 90^\circ)$$

$$\beta = 60^\circ$$

Q.34 A truck travelling due north at 20 m s^{-1} turns west and travels with same speed. What are the changes in velocity?

- (A) $20\sqrt{2} \text{ m s}^{-1}$ south-west
(B) 40 m s^{-1} south-west
(C) $20\sqrt{2} \text{ m s}^{-1}$ north-west
(D) 40 m s^{-1} north-west

[A]

Sol. $\vec{v}_1 = 20 \text{ m/s}$ due north

$$\vec{v}_2 = 20 \text{ m/s}$$
 due west

$$|\vec{v}_2 - \vec{v}_1| = \sqrt{v_1^2 + v_2^2 - 2v_1v_2\cos\theta}$$

$$= \sqrt{20^2 + 20^2 - 0} \quad [\because \theta = 90^\circ]$$

$$= 20\sqrt{2} \text{ m/s}$$

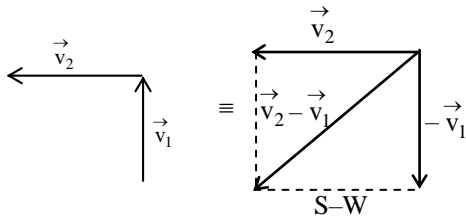

Direction of $\vec{v}_2 - \vec{v}_1$ is due South -West

Q.35 Let $\vec{A} = \frac{1}{\sqrt{2}} \cos \theta \hat{i} + \frac{1}{\sqrt{2}} \sin \theta \hat{j}$ be any vector.

What will be the unit vector \hat{n} in the direction of \vec{A} ?

- (A) $\cos \theta \hat{i} + \sin \theta \hat{j}$
 (B) $-\cos \theta \hat{i} - \sin \theta \hat{j}$
 (C) $1/\sqrt{2} (\cos \theta \hat{i} + \sin \theta \hat{j})$
 (D) $1/\sqrt{2} (\cos \theta \hat{i} - \sin \theta \hat{j})$

[A]

Sol. $\therefore \vec{A} = \frac{1}{\sqrt{2}} \cos \theta \hat{i} + \frac{1}{\sqrt{2}} \sin \theta \hat{j}$

$$\therefore |\vec{A}| = \frac{1}{\sqrt{2}} \sqrt{\cos^2 \theta + \sin^2 \theta} = \frac{1}{\sqrt{2}}$$

$$\Rightarrow \hat{n} = \frac{\vec{A}}{|\vec{A}|} = \cos \theta \hat{i} + \sin \theta \hat{j}$$

Q.36 The area of the triangle whose vertices are A (1, -1, 2), B(2, 1, -1) and C (3, -1, 2) is -

- (A) 26
 (B) $7\sqrt{13}$
 (C) $\sqrt{13}$
 (D) 8

[C]

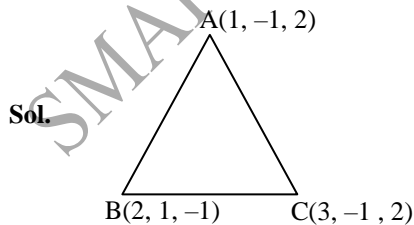

$$\vec{AB} = \hat{i} + 2\hat{j} - 3\hat{k}$$

$$\vec{BC} = \hat{i} - 2\hat{j} + 3\hat{k}$$

$$\vec{AB} \times \vec{BC} = \begin{vmatrix} \hat{i} & \hat{j} & \hat{k} \\ 1 & 2 & -3 \\ 1 & -2 & 3 \end{vmatrix} = -6\hat{j} - 4\hat{k}$$

$$|\vec{AB} \times \vec{BC}| = \sqrt{(-6)^2 + (-4)^2} = \sqrt{52} \text{ unit}$$

$$\therefore \text{Area of } \Delta = \frac{1}{2} |\vec{AB} \times \vec{BC}| = \sqrt{13} \text{ unit}$$

Q.37 An engine exerts a force $\vec{F} = (20\hat{i} - 3\hat{j} + 5\hat{k})\text{N}$

and moves with velocity $\vec{v} = (6\hat{i} + 20\hat{j} - 3\hat{k})\text{m/s}$. The power of the engine (in watt) is -

- (A) 45
 (B) 75
 (C) 20
 (D) 10

[A]

Sol. $\therefore P = \vec{F} \cdot \vec{v} = (20\hat{i} - 3\hat{j} + 5\hat{k}) \cdot (6\hat{i} + 20\hat{j} - 3\hat{k})$
 $= 120 - 60 - 15 = 45 \text{ W}$

Q.38 The maximum and the minimum magnitudes of the resultant of two given vectors are 17 unit and 7 unit respectively. If these two vectors are at right angles to each other, the magnitude of their resultant is -

- (A) 14
 (B) 16
 (C) 18
 (D) 13

[D]

Sol. $\therefore A + B = 17$

$$\& A - B = 7 \Rightarrow \begin{cases} A = 12 \\ B = 5 \end{cases}$$

$$\therefore \theta = 90^\circ$$

$$\therefore R = \sqrt{A^2 + B^2} = \sqrt{12^2 + 5^2} = 13 \text{ unit}$$

Q.39 A vector of magnitude a is rotated through an angle θ . What is the magnitude of the change in the vector?

- (A) $2a \sin \frac{\theta}{2}$
 (B) $2a \cos \frac{\theta}{2}$
 (C) $2a \sin \theta$
 (D) $2a \cos \theta$

[A]

Sol.

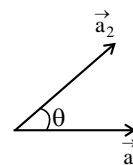

$$|\vec{a}_1| = |\vec{a}_2| = a$$

$$|\Delta \vec{a}| = |\vec{a}_2 - \vec{a}_1|$$

$$= \sqrt{a_1^2 + a_2^2 - 2a_1a_2 \cos\theta}$$

$$= \sqrt{a^2 + a^2 - 2a^2 \cos\theta}$$

$$= 2a \sin \theta/2$$

Q.40 Resultant of two vectors \vec{F}_1 and \vec{F}_2 is of magnitude

P. If \vec{F}_2 is reversed, then resultant is of magnitude Q. What is the value of $P^2 + Q^2$?

(A) $F_1^2 + F_2^2$

(B) $F_1^2 - F_2^2$

(C) $2(F_1^2 - F_2^2)$

(D) $2(F_1^2 + F_2^2)$

[D]

Sol. $\therefore |\vec{F}_1 + \vec{F}_2| = P$

$$\Rightarrow F_1^2 + F_2^2 + 2F_1F_2 \cos\theta = P^2 \dots(1)$$

& $|\vec{F}_1 - \vec{F}_2| = Q$

$$\Rightarrow F_1^2 + F_2^2 - 2F_1F_2 \cos\theta = Q^2 \dots(2)$$

$$(1) + (2), \quad \boxed{2(F_1^2 + F_2^2) = P^2 + Q^2}$$

Q.41 An athlete completes one round of a circular track of radius R in 40 second. What will be his displacement at the end of 2 minute 20 second?

(A) Zero

(B) 2R

(C) $2\pi R$

(D) $7\pi R$

[B]

Sol. 2 min 20 second = 140 second

\therefore He complete one round in 40 sec, thus he will complete 3 round in 120 sec. and half round in 20 sec, thus his displacement is 2R.

Q.42 A body covered a distance of 5 m along a semicircular path. The ratio of distance to displacement is -

(A) 11 : 7

(B) 12 : 5

(C) 8 : 3

(D) 7 : 5

[A]

Sol. In semi-circular path, Distance = πr

& Displacement = 2r

\therefore

$$\frac{\text{Distance}}{\text{Displacement}} = \frac{\pi r}{2r} = \frac{\pi}{2} = \frac{11}{7}$$

Q.43 For two vectors \vec{a} and \vec{b} , if $\vec{R} = \vec{a} + \vec{b}$ and

$\vec{S} = \vec{a} - \vec{b}$, if $2|\vec{R}| = |\vec{S}|$, when \vec{R} is

perpendicular to \vec{a} , then -

(A) $\frac{a}{b} = \sqrt{\frac{3}{7}}$

(B) $\frac{a}{b} = \sqrt{\frac{7}{3}}$

(C) $\frac{a}{b} = \sqrt{\frac{1}{5}}$

(D) $\frac{a}{b} = \sqrt{\frac{5}{1}}$

[A]

Sol. As \vec{R} is perpendicular to \vec{a} therefore

$$\cos \theta = \frac{-a}{b} \Rightarrow R = \sqrt{b^2 - a^2} \quad \text{and} \quad S = \sqrt{3a^2 + b^2}$$

As $2|\vec{R}| = |\vec{S}|$

$$\Rightarrow 4b^2 - 4a^2 = 3a^2 + b^2 \Rightarrow 3b^2 = 7a^2$$

Q.44 If $\vec{r} = bt^2 \hat{i} + ct^3 \hat{j}$, where b and c are positive constant, the time at which velocity vector makes an angle $\theta = 60^\circ$ with positive y-axis is -

(A) $\frac{c}{b}$

(B) $\frac{2b}{3\sqrt{3}c}$

(C) $\frac{2c}{\sqrt{3}b}$

(D) $\frac{2b}{\sqrt{3}c}$

[B]

Sol. $\frac{d\vec{r}}{dt} = 2bt \hat{i} + 3ct^2 \hat{j}$

$$\tan 60^\circ = \frac{2bt}{3ct^2}$$

$$\Rightarrow t = \frac{2b}{3\sqrt{3}c}$$

Q.45 Two vectors \vec{A} and \vec{B} are given in the figure :

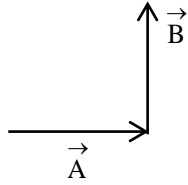

Then $\vec{A} - \vec{B}$ is given by -

- (A) (B)
 (C) (D) None of these
- [D]

Sol.

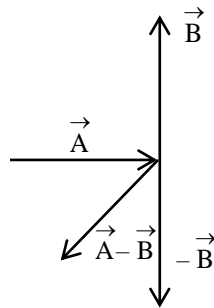

Q.46 Resultant of two vectors \vec{A} and \vec{B} is \vec{R} . Now magnitude of vector is doubled keeping direction same, then magnitude of the resultant becomes $|\vec{B}|$. Angle between vector \vec{A} and \vec{B} is 120° . Then magnitude of \vec{A} is equal to -

- (A) $|\vec{B}|$ (B) $2|\vec{B}|$
 (C) $\frac{|\vec{B}|}{2}$ (D) $4|\vec{B}|$
- [C]

Sol. $2|\vec{A}| = |\vec{B}|$

$$|\vec{A}| = \frac{|\vec{B}|}{2}$$

Q.47 A man can row a boat with speed v_{br} in still water, speed of river flow is v_r and v_r is two times of v_{br} . Man reach one bank to other bank and follow a path so that the path

traveled by boat is shortest. Then angle between velocity vector of boat in still water and current flow of water in river is -

- (A) 30° (B) 60°
 (C) 90° (D) 120°

[D]

Sol. For shortest path when $v_{br} < v_r$.

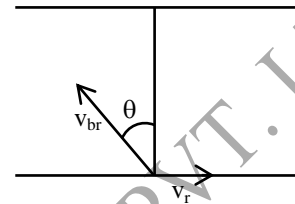

$$\sin \theta = \frac{v_{br}}{v_r}$$

Q.48 A man can row a boat with speed v_{br} in still water, speed of river flow is v_r and v_r is two times of v_{br} . Man reach one bank to other bank and follow a path so that the path traveled by boat is shortest. Then angle between velocity vector of boat in still water and current flow of water in river is -

- (A) 30° (B) 60°
 (C) 90° (D) 120° [D]

Sol. For shortest path when $v_{br} < v_r$.

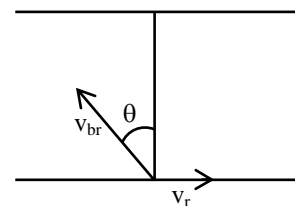

$$\sin \theta = \frac{v_{br}}{v_r}$$

Q.48 Vector \vec{R} is the resultant of the vectors \vec{A} and \vec{B} .

Ratio of minimum value of $|\vec{R}|$ and

maximum value of $|\vec{R}|$ is $\frac{1}{4}$. Then $\frac{|\vec{A}|}{|\vec{B}|}$ may

be -

- (A) $\frac{4}{1}$ (B) $\frac{2}{1}$

- (C) $\frac{3}{5}$ (D) $\frac{1}{4}$

[C]

Sol. $\frac{|\vec{R}|_{\min}}{|\vec{R}|_{\max}} = \frac{1}{4} = \frac{\|\vec{A} - \vec{B}\|}{\|\vec{A} + \vec{B}\|}$

$$|\vec{A} + \vec{B}| = 4 \|\vec{A} - \vec{B}\|$$

If $|\vec{A}| > |\vec{B}|$

$$|\vec{A} + \vec{B}| = 4 (|\vec{A}| - |\vec{B}|)$$

$$3 |\vec{A}| = 5 |\vec{B}| \Rightarrow \frac{|\vec{A}|}{|\vec{B}|} = \frac{5}{3}$$

If $|\vec{B}| > |\vec{A}|$

$$|\vec{A} + \vec{B}| = 4 (|\vec{B}| - |\vec{A}|)$$

$$\frac{|\vec{A}|}{|\vec{B}|} = \frac{3}{5}$$

Q.49 A launch takes 3 hours to go downstream from point A to point B and 6 hours to come back. Time taken by this launch to cover the distance AB downstream when its engine cut-off is –

- (A) 3 hr (B) 6 hr
(C) 9 hr (D) 12 hr

[D]

Sol. $T = \frac{2t_1 t_2}{t_2 - t_1} = 12 \text{ hr}$

Q.50 There are two vectors $\vec{A} = \hat{i} + \hat{j} + \hat{k}$ and

$\vec{B} = \hat{i} - \hat{j} + \hat{k}$, then component of \vec{A} along \vec{B}

(A) $\frac{1}{\sqrt{3}} (\hat{i} - \hat{j} + \hat{k})$ (B) $\frac{1}{\sqrt{3}} (\hat{i} + \hat{j} + \hat{k})$

(C) $\sqrt{3} (\hat{i} + \hat{j} + \hat{k})$ (D) $(\hat{i} - \hat{j} + \hat{k})$

[B]

Sol. Component of \vec{A} along $\vec{B} = \left(\frac{\vec{A} \cdot \vec{B}}{|\vec{B}|} \right) \hat{B}$

PHYSICS

Q.1 On a horizontal ground, rabbit is at origin and a cat is at position (46m, 28m). When the rabbit starts running with velocity $(7.5\hat{i} + 10\hat{j})$ m/s cat also starts running. If cat can run with maximum speed of 5 m/s. What is the minimum time in which cat can catch the rabbit ? (in seconds)

[0004]

Q.2 Two forces of magnitude 6 N and 10 N are acting at a point. Resultant of these force is perpendicular to 6N. Then find the magnitude of the resultant force.

[0008]

Q.3 Three forces are acting at a point as shown in figure. All forces are acting in a plane. Find the magnitude of resultant of these forces.

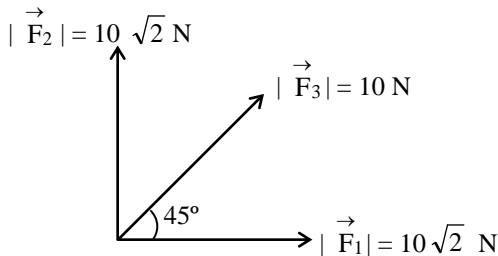

[0030]

Q.4 On an open ground, a motorist follows a truck that runs to his left by an angle 60° after every 500 m. Starting from a given turn specify the displacement (in meter) of motorist at the third turn.

[1000]

Q.5 Two forces of magnitude 6N and 10N are acting at a point. Resultant of these force is perpendicular to 6 N. Then find the magnitude of the resultant force.

[0008]

Q.6 Three forces are acting at a point as shown in figure.

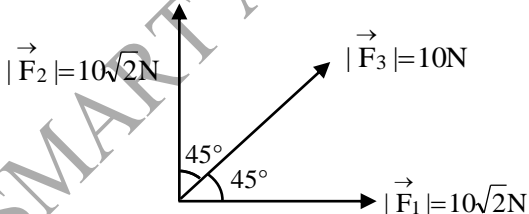

All forces are acting in a plane. Find the magnitude of resultant of these forces.

[0030]

Q.7 In the figure shown, the velocity of lift is 2m/s while string is winding on the motor shaft with velocity 2m/s and block A is moving downwards

with a velocity of 2m/s, the velocity of block B in m/s is-

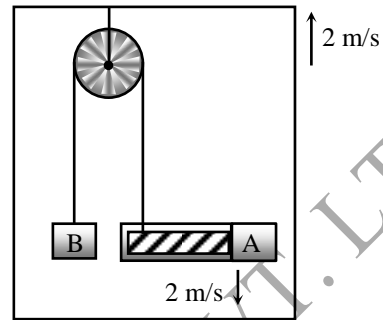

Sol.

$$\vec{V}_{B\ell} = 4 \text{ m/s } \uparrow$$

$$\vec{V}_{B\ell} = \vec{V}_B - \vec{V}_\ell$$

$$4 \text{ m/s} = \vec{V}_B - 2 \text{ m/s}$$

$$\vec{V}_B = 4 + 2 = 6 \text{ m/s.}$$

Q.8

Two men P & Q are standing at corners A & B of square ABCD of side 8 m. They start moving along the tank with constant speed 2m/s and 10 m/s respectively. The time when they will meet for the first time, in second is -

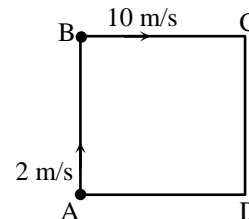

Sol.

Relative displacement = relative velocity \times time

$$8 \times 3 = (10 - 2)t$$

$$\Rightarrow t = 3 \text{ sec}$$

Q.9

Two motor vehicles run at constant speeds 5 m/s each along highways intersecting at an angle 60° . In what time after they meet at the intersection will the distance between the vehicles be $10\sqrt{3}$ m.

Sol.

u_{12} = Speed of second vehicle with respect to the first one

$$u_{12}^2 = v_1^2 + v_2^2 + 2v_1v_2 \cos \alpha$$

$$= (5^2 + 5^2 + 2 \times 5 \times 5 \cos 60^\circ) \text{ m}^2/\text{s}^2$$

$$u_{12} = 5\sqrt{3} \text{ m/s}$$

$$t = \frac{S}{v_{1/2}} = \frac{10\sqrt{3}}{5\sqrt{3}} \text{ s} = 2 \text{ s}$$

Q.10 Magnitude of resultant of two vector \vec{A} and \vec{B} is equal to 2. Angle between two vectors is 180° . If $|\vec{A}| = 3$ then find $|\vec{B}|$ ($|\vec{B}|$ must be less than 2)

Sol. [1] (Given $|A| = 3$)

$$|\vec{A}| - |\vec{B}| = 2 \quad |\vec{B}| > |\vec{A}|$$

$$|\vec{B}| = 1$$

Q.11 Magnitude of subtraction of two vector \vec{A} and \vec{B} is equal to 5. Angle between both is 180° . Find the magnitude of resultant of these two vectors. If

$$|\vec{A}| = 2. \quad [1]$$

Sol. $|\vec{A}| + |\vec{B}| = 5$

$$2 + |\vec{B}| = 5$$

$$|\vec{B}| = 3$$

resultant of $|\vec{A}|$ and $|\vec{B}|$

$$|\vec{B}| - |\vec{A}| = 3 - 2 = 1$$

Q.12 A swimmer jumps from a bridge over a canal and swims 1 km up stream. After that first km, he passes a floating cork. He continues swimming for half an hour and then turns around and swims back to the bridge. The swimmer and the cork reach the bridge at the same time. The swimmer has been swimming at a constant speed. How fast does the water in the canal flow in km/hr.

Sol.[1] Let $V_w = u$ & $U_{sw} = v$

Time taken by swimmer to go from M to O and O to B = time taken by float to reach B from M.

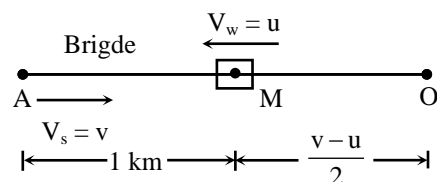

$$= \frac{1}{2} + \frac{1 + \frac{v-u}{2}}{v+u} = \frac{1}{u}$$

$$\Rightarrow \frac{1}{2} + \frac{2+v-u}{2(v+u)} = \frac{1}{u}$$

$$\Rightarrow \frac{(v+u+2+v-u)}{2(v+u)} = \frac{1}{u}$$

$$\Rightarrow (2v+2)u = 2(v+u)$$

$$\Rightarrow 2vu + 2u = 2v + 2u$$

$$u = 1 \text{ km/hr}$$

Q.16 Two particles are moving with velocity $\vec{v}_1 = \hat{i} - 2t\hat{j} \text{ m/s}$ and $\vec{v}_2 = 4\hat{i} + \hat{j} \text{ m/s}$ respectively. Time at which they are moving perpendicular to each other is.

Sol. [2] $\vec{v}_1 \cdot \vec{v}_2 = 0 \Rightarrow t = 2 \text{ sec}$

Q.17 Motion of a particle is defined by the position

$$\text{vector } \vec{r} = A(\cos t + t \sin t) \hat{i} + A(\sin t - t \cos t) \hat{j},$$

where t is time in sec. Value of 't' for which position vector and acceleration are perpendicular to each other is –

Sol. [1] $\vec{a} = \frac{d^2 \vec{r}}{dt^2}$

\vec{r} and \vec{a} are perpendicular if $\vec{r} \cdot \vec{a} = 0$

Q.18 Magnitude of resultant of two vector \vec{A} and \vec{B} is equal to 2. Angle between two vectors is 180° . If

$|\vec{A}| = 3$ then find $|\vec{B}|$ ($|\vec{B}|$ must be less than 2)

Sol.[1] (Given $|A| = 3$)

$$|\vec{A}| - |\vec{B}| = 2 \quad |\vec{B}| > |\vec{A}|$$

$$|\vec{B}| = 1$$

Q.19 Magnitude of subtraction of two vector \vec{A} and \vec{B} is equal to 5. Angle between both is 180° . Find the magnitude of resultant of these two vectors.

If $|\vec{A}| = 2.$

Sol.[1] $|\vec{A}| + |\vec{B}| = 5$

$$2 + |\vec{B}| = 5$$

resultant of $|\vec{A}|$ and $|\vec{B}|$

$$|\vec{B}| - |\vec{A}| = 3 - 2 = 1$$

SMART ACHIEVERS LEARNING PVT. LTD.