

PHYSICS

Q.1 Which one is showing the characteristics of a zener diode ?

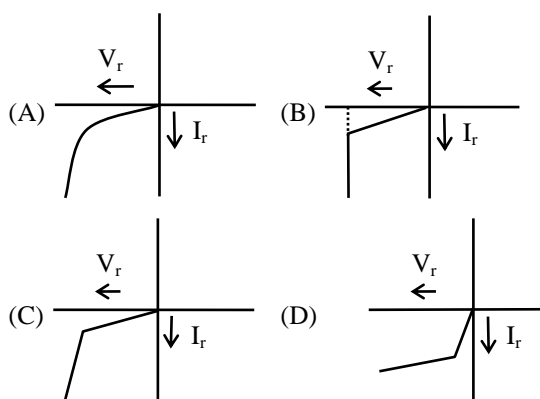

[B]

Q.2 A zener diode is to be used as a voltage regulator. Identify the correct set up –

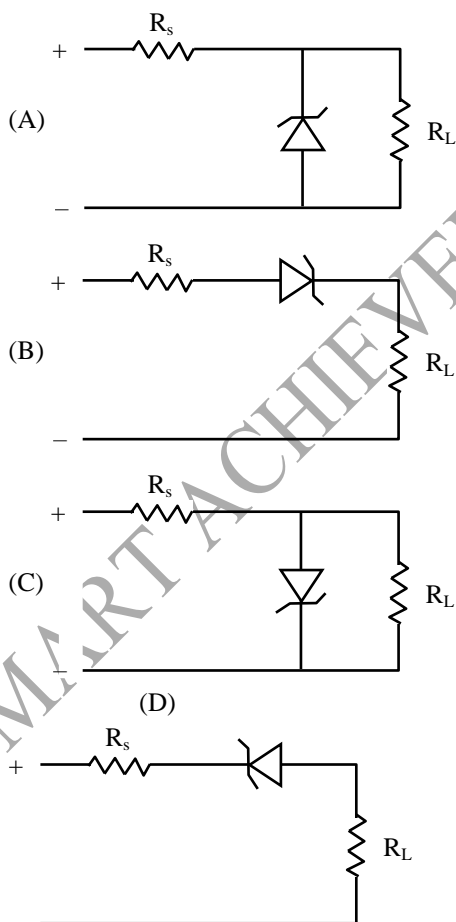

[A]

Sol. Zener diode is in parallel to load resistance and is connected in reverse bias.

Q.3 If a semiconductor has an intrinsic carrier concentration of $1.41 \times 10^{16} \text{ m}^{-3}$, when doped with 10^{21} m^{-3} phosphorus, then the concentration of holes at room temperature will be –

- (A) 2×10^{21} (B) 2×10^{11}
(C) 1.41×10^{10} (D) 1.41×10^{16} [D]

Sol. Phosphorus is pentavalent impurity. Its doping will not effect the concentration of holes. So number of holes will be equal to same as in intrinsic semiconductor. So $n_h = 1.41 \times 10^{16} \text{ m}^{-3}$

Q.4 If lattice parameter for a crystalline structure is 3.6 \AA , then atomic radius in fcc crystal in Å is –
(A) 7.20 \AA (B) 1.80 \AA
(C) 1.27 \AA (D) 2.90 \AA [C]

Sol. Atomic radius for fcc crystal is

$$r = \frac{a}{2\sqrt{2}} = \frac{3.6}{2\sqrt{2}} \text{ \AA} = 1.27 \text{ \AA}$$

Q.5 In a p-type semiconductor the acceptor level is situated 57 meV above the valence band. The maximum wavelength of light required to produce a hole will be –

- (A) 57 \AA (B) $57 \times 10^{-3} \text{ \AA}$
(C) 217100 \AA (D) $11.61 \times 10^{-33} \text{ m}$

[C]

Sol. $\lambda = \frac{hc}{eE} = \frac{6.62 \times 10^{-34} \times 3 \times 10^8 \times 10^{10}}{1.6 \times 10^{-19} \times 57 \times 10^{-3}} \text{ \AA}$
 $= 217100 \text{ \AA}$

Q.6 An $p-n$ junction (D) shown in the figure can act as a rectifier. An alternating current source (V) is connected in the circuit.

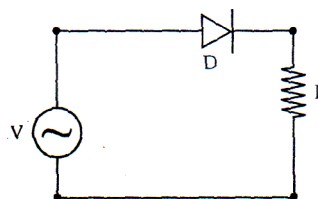

The current (I) in the resistor R can be shown by

[AIEEE-2009]

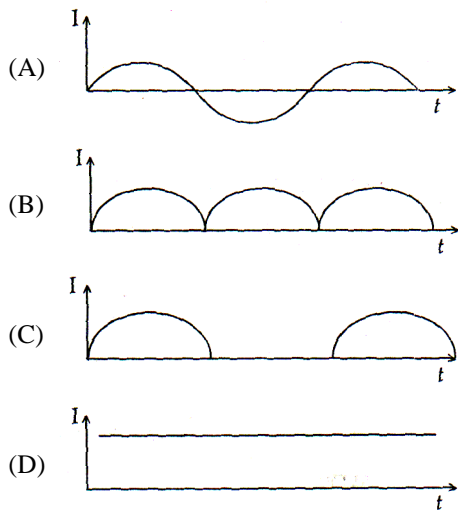

[C]

Sol. The diode will be forward biased in one half cycle and will conduct where as it will be reverse biased in negative half cycle and will not conduct.

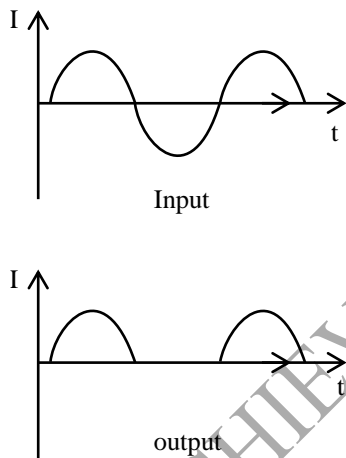

Q.7 What is out put Y of the gate circuit shown in figure?

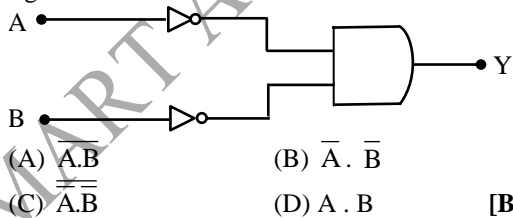

Q.8 A T.V. tower has a height of 150 m. The area of the region covered, the T.V. broadcast is (radius of earth = 6.4×10^6 m) -
 (A) $9.6 \pi \times 10^8 \text{ m}^2$ (B) $19.2\pi \times 10^8 \text{ m}^2$
 (C) $19.2 \pi \times 10^7 \text{ m}^2$ (D) $1.92\pi \times 10^3 \text{ km}^2$ [B]

Sol. Area of the region covered for broadcasting
 $= \pi d^2 = \pi(2hR)$
 $= \pi \times 2 \times 150 \times 6.4 \times 10^6$

$$= \pi \times 300 \times 6.4 \times 10^6$$

$$= 19.2 \times \pi \times 10^8 \text{ m}^2$$

Q.9 The logic circuit shown below has the input waveforms 'A' and 'B' as shown. Pick out the correct output waveform. [AIEEE-2009]

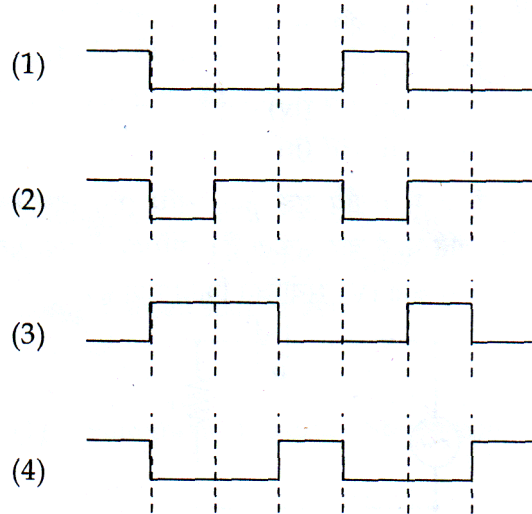
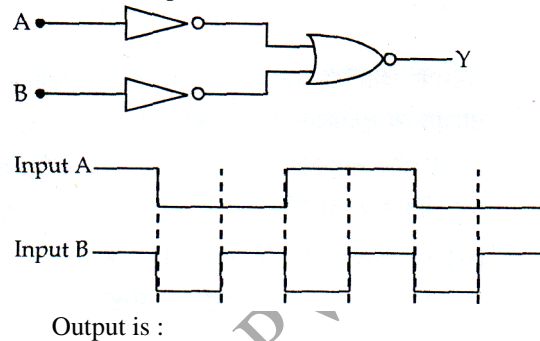

[1]

Sol.

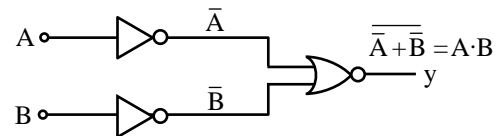

The out put will be of AND gate.

A	B	Y = A · B
0	0	0
0	1	0
1	0	0
1	1	1

The output will be high only when both the inputs are high hence correct .

Q.10 An n - p - n transistor circuit has $\alpha = 0.985$. If $I_c = 2\text{mA}$, then value of I_b is -

- (A) 0.03 mA (B) 0.003 mA
 (C) 0.66 mA (D) 0.015 mA [A]

Sol. $\alpha = \frac{I_c}{I_e} = \frac{I_c}{I_c + I_b} = 0.985$
 $I_c = 0.985 (I_c + I_b)$
 $I_c = 0.985 I_c + 0.985 I_b$
 $0.985 I_b = 0.015 I_c = 0.015 \times 2 \text{ mA}$
 $I_b = \frac{0.015 \times 2}{0.985} = 0.03 \text{ mA}$
 $I_b \approx 0.03 \text{ mA}$

- Q.11** If input in a full-wave rectifier is $e = 50 \sin 314t$ volt, diode resistance is 100Ω and load resistance is $1 \text{ K} \Omega$ then.
 (1) Pulse frequency output voltage is 100.
 (2) Input power is 1136 mw
 (3) Output power is 827 mw
 (4) Efficiency is 81.2 %
 (A) 1, 3 (B) 1, 2
 (C) 1, 2, 3 (D) 1,2,3,4 [C]

- Q.12** An n-p-n transistor circuit is arranged as shown, it is a –

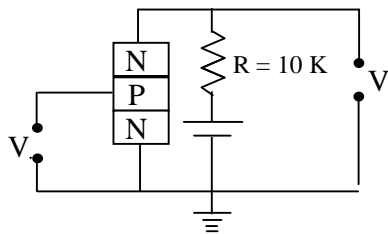

- (A) Common base amplifier circuit
 (B) Common-emitter amplifier circuit
 (C) Common-collector amplifier circuit
 (D) None [B]

- Q.13** In N-type semiconductors, the concentration of minority charge carriers mainly depends upon –
 (A) the doping technique
 (B) the doping ratio
 (C) the temperature of the material
 (D) None [C]

- Q.14** An P-N-P transistor circuit is arranged as shown. It is a –

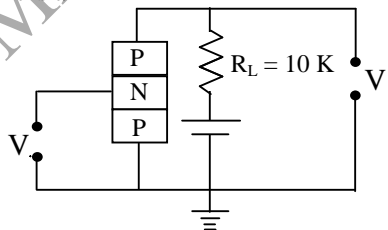

- (A) common base amplifier circuit
 (B) common-emitter amplifier circuit
 (C) common-collector circuit

- (D) None [C]
Q.15 Following circuit is equivalent to –

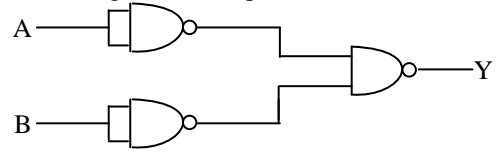

- (A) AND gate (B) OR gate
 (C) NOT gate (D) X-OR gate [B]

Sol. $Y = \overline{\overline{A} \cdot \overline{B}} = A + B$ i.e. OR gate

- Q.16** Refractive index of ionosphere is –
 (A) zero (B) less than one
 (C) one (D) more than one [B]

- Q.17** Current through the ideal diode is –

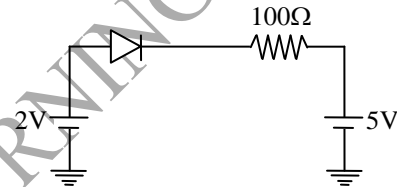

- (A) zero (B) 20 A (C) $\frac{1}{20}$ A (D) $\frac{1}{50}$ A

Sol.[A] PN Junction is in reverse bias.

- Q.18** 1 curie is equal to –
 (A) 3.7×10^{10} dps (B) 3×10^{10} dps
 (C) 5×10^{10} dps (D) none [A]

- Q.19** If n_e and n_h are the number of electrons and holes in a semi-conductor heavily doped with phosphorus, then –
 (A) $n_e \gg n_h$ (B) $n \leq n_h$
 (C) $n_e \ll n_h$ (D) none [A]

Sol. Phosphorus is V group element.

- Q.20** An n-type semi-conductor is –
 (A) negatively charged
 (B) positively charged
 (C) neutral
 (D) negatively or positively charged depending upon the amount of impurity [C]

Sol. n-type semi-conductor is neutral, net charge is zero.

- Q.21** In p-type semi-conductor the majority charge carriers are –
 (A) electrons (B) holes

(C) neutrons (D) protons [B]



- Q.22** Depletion layer in the p-n junction consists of -
 (A) electrons
 (B) holes
 (C) positive and negative ions fixed in their position
 (D) both electron and holes [C]

- Q.23** In a forward biased p-n junction, the current is of the order of -
 (A) ampere (B) milli-ampere
 (C) micro-ampere (D) nano-ampere [B]

- Q.24** The mobility of free electrons is greater than that of free holes because -
 (A) they carry negative charge
 (B) mutual collision in them is less
 (C) they require low energy to continue their motion
 (D) none of these [C]

- Q.25** The energy gap of a semiconductor is 1.10 eV. The maximum wavelength in Å at which it starts energy absorption will be -
 (A) 11.284 (B) 112.84
 (C) 1128.4 (D) 11284 [D]

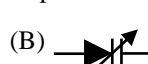
Sol. $E = \frac{hc}{\lambda}$
 $\lambda = \frac{19.8 \times 10^{-26}}{1.1 \times 1.6 \times 10^{-19}} = 11284 \text{ \AA}$

- Q.26** Symbolic representation of photodiode is -
 (A)  (B) 
 (C)  (D)  [C]

- Q.27** Zener diode is used as -
 (A) Half wave rectifier
 (B) Full wave rectifier
 (C) ac voltage stabilizer
 (D) dc voltage stabilizer [C]

- Q.28** The depletion layer in silicon diode is 1 μm wide and the knee potential is 0.6 V, then the electric field in the depletion layer will be -
 (A) Zero (B) 0.6V m⁻¹
 (C) 6 × 10⁴ V/m (D) 6 × 10⁵ V/m [D]

Sol. $E_{in} = \frac{\Delta V_b}{d} = \frac{0.6}{10^{-6}} = 6 \times 10^5 \text{ V/m}$

- Q.29** In the given figure, which of the diodes are forward biased?

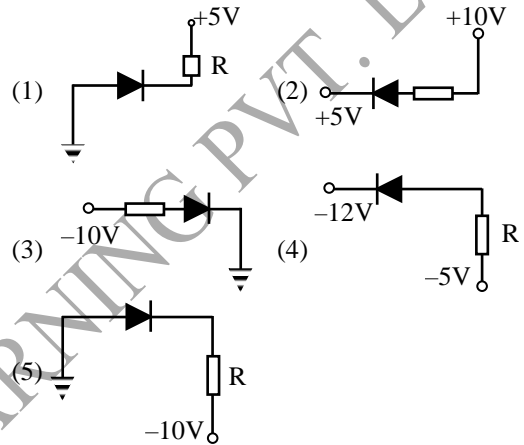

- (A) 1,2,3 (B) 2,4,5
 (C) 1,3,4 (D) 2,3,4 [B]

Sol. 2,4,5 → F.B., 1,3 → R.B.

- Q.30** The circuit shown in following figure contains two diode D₁ and D₂ each with a forward resistance of 50 ohms and with infinite backward resistance. If the battery voltage is 6V, the current through the 100 ohm resistance (in amperes) is -

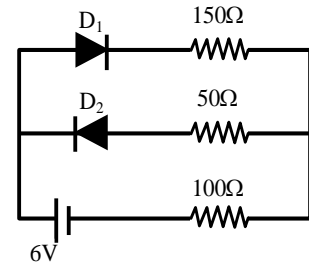

- (A) Zero (B) 0.02
 (C) 0.03 (D) 0.036 [B]

Sol. D₁ → F.B., D₂ → R.B

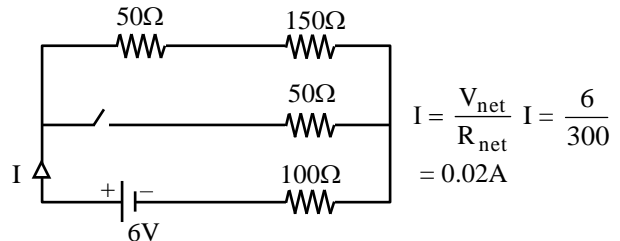

Q.31 A sinusoidal voltage of peak value 200 volt is connected to a diode and resistor R in the circuit shown so that half wave rectification occurs. If the forward resistance of the diode is negligible compared to R the rms voltage (in volt) across R is approximately -

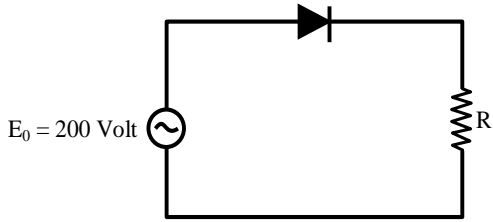

- (A) 200 (B) 100
(C) $\frac{200}{\sqrt{2}}$ (D) 280 [B]

Sol. $(V_{r.m.s.})_{H.W.R.} = \frac{V_0}{2} = \frac{200}{2} = 100$ volt

Q.32 Find V_{AB}

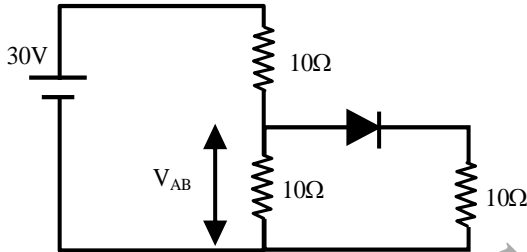

- (A) 10 V (B) 20 V
(C) 30 V (D) None of these [A]

Sol. Diode in F.B.

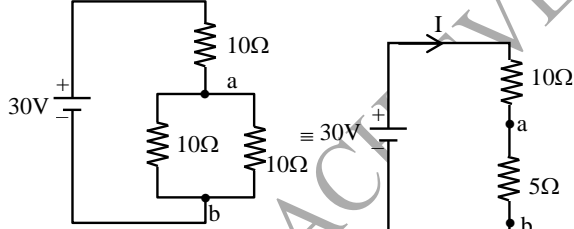

$$I = \frac{30}{15} = 2A, V_{ab} = IR_{ab} = 2 \times 5 = 10V$$

Q.33 In the following circuit find i_1 and i_2 -

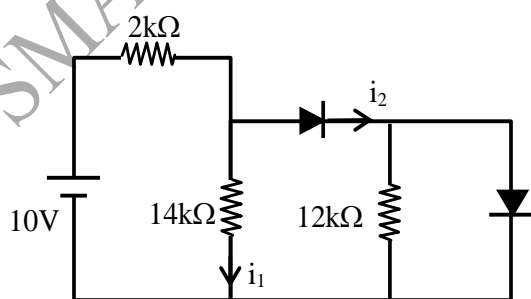

- (A) 0,0 (B) 5 mA, 5 mA
(C) 5 mA, 0 (D) 0.5 mA [D]

Q.34 Figure gives a system of logic gates. From the study of truth table it can be found that to produce a high output (1) at R, we must have -

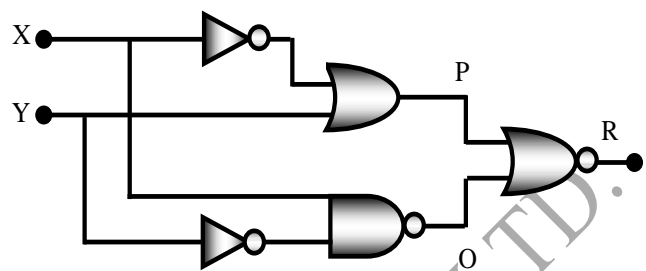

- (A) X = 0, Y = 1 (B) X = 1, Y = 1
(C) X = 1, Y = 0 (D) X = 0, Y = 0 [C]

Sol.

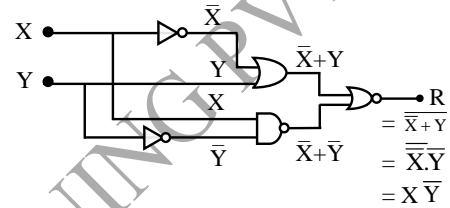

- * Out put R = X \bar{Y}
* If R = 1 it is possible when X = 1 & Y = 0

Q.35 In the circuit, if the forward voltage drop for the diode is 0.5V, the current will be -

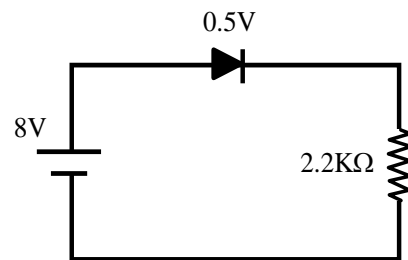

- (A) 3.4 mA (B) 2 mA
(C) 2.5 mA (D) 3 mA [A]

Sol. $I = \frac{V_{net}}{R_{net}} = \frac{8 - 0.5}{2.2 \times 10^{-3}} \text{ Amp.} = \frac{7.5}{2.2} \text{ mA} = 3.4 \text{ Ma}$

Q.36 In common base amplifier, the ratio of power gain and resistance gain is -

- (A) α (B) α^2 (C) $\frac{1}{\alpha}$ (D) $\frac{1}{\alpha^2}$

Sol.[B] $\frac{A_P}{A_R} = \frac{\alpha^2 A_R}{A_R} = \alpha^2$

Q.37 Given : $\beta = 80$ and $\Delta I_B = 250 \mu A$. The value of ΔI_C is -

- (A) $80 \times 250 \mu A$ (B) $(250 - 80) \mu A$

- (C) $(250 + 80) \mu\text{A}$ (D) $\frac{250}{80} \mu\text{A}$ [A]

Sol. $\Delta i_e = \beta \Delta i_B = 80 \times 250 \mu\text{A}$

- Q.38** To use a transistor as an amplifier -
 (A) emitter-base junction is forward biased and collector-base junction is reverse biased
 (B) both junctions are forward biased.
 (C) both junctions are reverse biased.
 (D) it does not matter how the transistor is biased, it always works as an amplifier.

Sol.[A] E – B junction is forward bias and C – B junction is reversed bias.

- Q.39** The forward biased diode is -

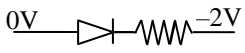
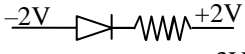
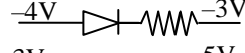
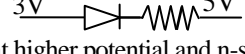
- (A)  (B) 
 (C)  (D) 

Sol. p-side at higher potential and n-side at lower potential. [A]

- Q.40** Broadcasting antennas are generally -

- (A) omnidirectional type
 (B) vertical type
 (C) horizontal type
 (D) none of these [A]

Sol. Broadcasting is done in all directions, so it is omni-directional.

- Q.41** In Fig., the current supplied by the battery is -

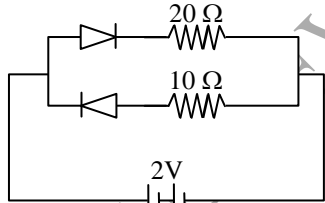

- (A) 0.1 A (B) 0.2 A (C) 0.3A (D) 0.4A [A]

Sol. Upper diode is in forward bias,
 So, $i = V/R = 2V/20\Omega = 0.1 \text{ A}$

- Q.42** The energy gap of silicon is 1.14eV. The maximum wavelength at which silicon will begin absorbing energy is -

- (A) 10855 Å (B) 1088.8 Å
 (C) 108.88 Å (D) 10.888 Å [A]

Sol. $\lambda = \frac{hc}{E} = \frac{12400}{1.41} \text{ Å} = 10877 \text{ Å}$

- Q.43** What should be height of transmitting antenna if the T.V. telecast is to cover a radius of 128 km ?

- (A) 1560 m (B) 1280 m
 (C) 1050 m (D) 79 m [B]

Sol. $h = \frac{d^2}{2R} = \frac{128 \times 128}{2 \times 6400} = 1.28 \text{ km}$

- Q.44** Which logic gate is represented by the following combination of logic gates ?

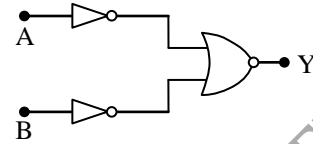

- (A) OR (B) NAND
 (C) AND (D) NOR [C]

Sol. $Y = \overline{(\overline{A} + \overline{B})} \Rightarrow$

A	B	Y
0	0	0
0	1	0
1	0	0
1	1	1

= AND

- Q.45** If the half-lives of a radioactive element for α and β decay are 4 year and 12 years respectively, then the percentage of the element that remains after 12 year will be -

- (A) 6.25 % (B) 5.25%
 (C) 4.25 % (D) 3.50 % [A]

Sol. $T = 4 \times 12/4 + 12 = 3 \text{ yrs.}$

$$\frac{N}{N_0} = \left(\frac{1}{2}\right)^{12/3} = \left(\frac{1}{2}\right)^4 = \frac{1}{16} = \frac{100}{16} \% = 6.25\%$$

- Q.46** In a common base transistor circuit, the current gain is 0.98. On changing emitter current by 5.00 mA, the change in collector current is -

- (A) 0.196 mA (B) 2.45 mA
 (C) 4.9 mA (D) 5.1 mA [C]

Sol. $\Delta i_c = \alpha \Delta i_e = 0.98 \times 5 \text{ mA} = 4.9 \text{ mA}$

- Q.47** Input waveforms A and B as shown in Fig-I are applied to the combination of gates as shown in Fig-II. Which of the waveforms shown in Fig. (i) to (iv) correctly represents the output waveform ?

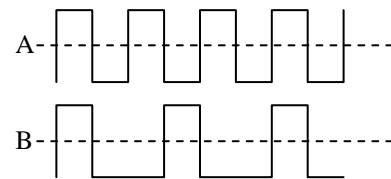

Fig-I

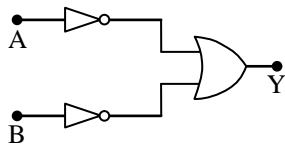

Fig-II

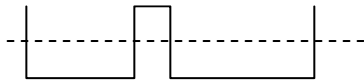

Fig-(i)

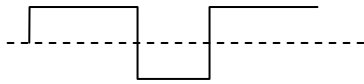

Fig-(ii)

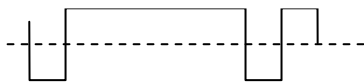

Fig-(iii)

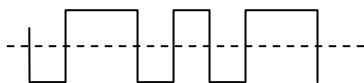

Fig-(iv)

- (A) Fig.(i) (B) Fig.(ii)
 (C) Fig.(iii) (D) Fig. (iv) [C]

Sol.

$$Y = \bar{A} + \bar{B}$$

A	B	Y
0	0	1
0	1	1
1	0	1
1	1	0

$$\Rightarrow \begin{array}{r} 10101010 \\ +10010010 \\ \hline 01111101 \end{array}$$

So, output is 'zero' when both inputs are 'one'. In all other cases output is one.

Q.48 The relation between α and β parameters of a transistor is given by -

- (A) $\alpha = \frac{1+\beta}{\beta}$ (B) $\alpha = \frac{1-\beta}{\beta}$
 (C) $\alpha = \frac{\beta}{1+\beta}$ (D) $\alpha = \frac{\beta}{1-\beta}$

Sol[C] α and β both are amplification factors

Q.49 If l_1, l_2, l_3 are the lengths of the emitter, base and collector of a transistor, then -

- (A) $l_1 = l_2 = l_3$ (B) $l_3 < l_2 > l_1$
 (C) $l_3 < l_1 < l_2$ (D) $l_3 > l_1 > l_2$

Sol. [D] From basic knowledge, l_2 is least

Q.50 Which one is reverse-biased?

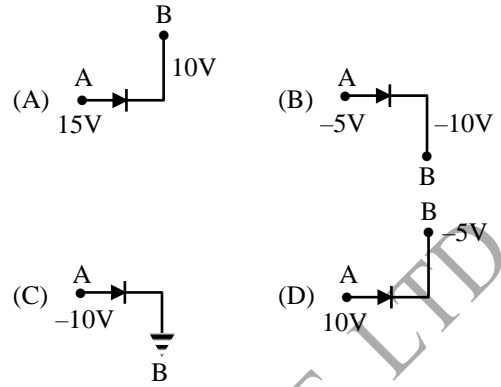

Ans. [C] For reverse bias P of diode should be at lower potential