

# PHYSICS

- Q.1** A, B and C are voltmeters of resistances  $R$ ,  $1.5 R$  and  $3 R$  respectively. When some potential difference is applied between X and Y, the voltmeter readings are  $V_A$ ,  $V_B$  and  $V_C$  respectively -

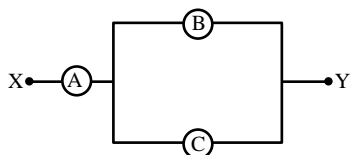

- (A)  $V_A = V_B = V_C$       (B)  $V_A \neq V_B = V_C$   
 (C)  $V_A = V_B \neq V_C$       (D)  $V_B \neq V_A = V_C$
- [A]

- Q.2** In the circuit, each resistance is  $20 \Omega$ . The readings of  $A_1$ ,  $A_2$  and  $A_3$  are respectively -

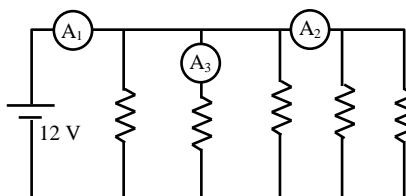

- (A) 3A, 1.8A, 1.2 A  
 (B) 3A, 1.2 A, 0.6A  
 (C) 3A, 0.6 A, 1.2 A  
 (D) 3A, 0.6 A, 0.6 A
- [B]

- Q.3** In the electric circuit shown in figure, the reading of voltmeter  $V_1$  is 26 volt, and the reading of ammeter  $A_1$  is 2 ampere. The value of resistance  $x$  is -

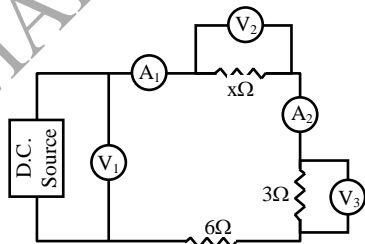

- (A)  $2 \Omega$     (B)  $4 \Omega$     (C)  $6 \Omega$     (D)  $8 \Omega$

[B]

- Q.4** In the figure, the potentiometer wire AB of length  $L$  and resistance  $9r$  is joined to the cell D of emf  $\epsilon$  and internal resistance  $r$ . The cell C's emf is  $\epsilon/2$  and its internal resistance is  $2r$ . The galvanometer G will show no deflection when the length AJ is -

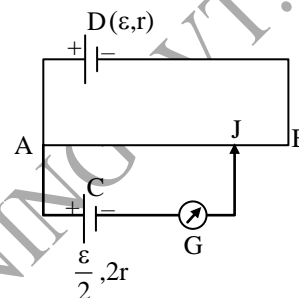

- (A)  $\frac{4L}{9}$       (B)  $\frac{5L}{9}$   
 (C)  $\frac{7L}{18}$       (D)  $\frac{11L}{18}$
- [B]

- Q.5** In the circuit shown the variable resistance  $R_h$  is so adjusted that ammeter reads the same in both positions of the key. The reading of ammeter is  $I$ . The emf of the cell in series with  $x$  is  $E$ , the value of  $x$  is -

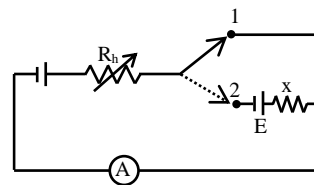

- (A)  $\frac{2E}{I}$       (B)  $\frac{E}{I}$   
 (C)  $EI$       (D)  $2EI$
- [B]

**Q.6** In the arrangement shown in figure when the switch  $S_2$  is open, the galvanometer shows no deflection for  $\ell = L/2$ . When the switch  $S_2$  is closed, the galvanometer shows no deflection for  $\ell = 5L/12$ . The internal resistance ( $r$ ) of 6 V cell, and the emf  $E$  of the other battery are respectively-

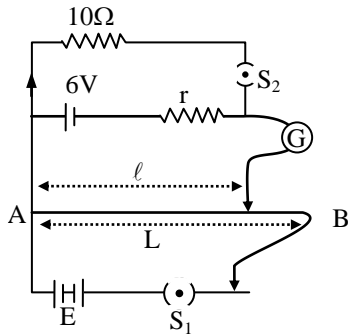

- (A)  $3\Omega, 8V$  (B)  $2\Omega, 12V$   
 (C)  $2\Omega, 24V$  (D)  $3\Omega, 12V$  [B]

**Q.7** In the circuit shown in figure reading of voltmeter is  $V_1$  when only  $S_1$  is closed, reading of voltmeter is  $V_2$  when only  $S_2$  is closed and reading of voltmeter is  $V_3$  when both  $S_1$  and  $S_2$  are closed. Then-

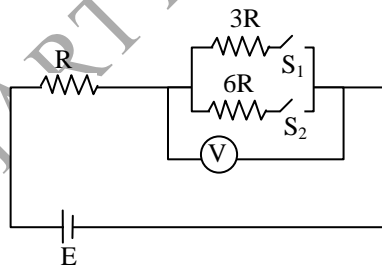

- (A)  $V_3 > V_2 > V_1$  (B)  $V_2 > V_1 > V_3$   
 (C)  $V_3 > V_1 > V_2$  (D)  $V_1 > V_2 > V_3$

[B]

**Q.8** In the circuit  $P \neq R$ , the reading of the galvanometer is same with switch  $S$  open or closed. Then – [IIT- JEE 99]

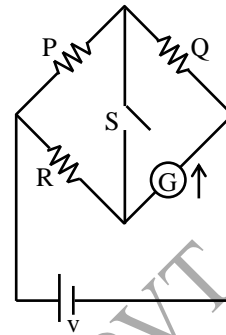

- (A)  $I_R = I_G$  (B)  $I_P = I_G$   
 (C)  $I_Q = I_G$  (D)  $I_Q = I_R$  [A]

**Q.9** Which of the following circuit is correct for verification of ohms law– [IIT- JEE 2003]

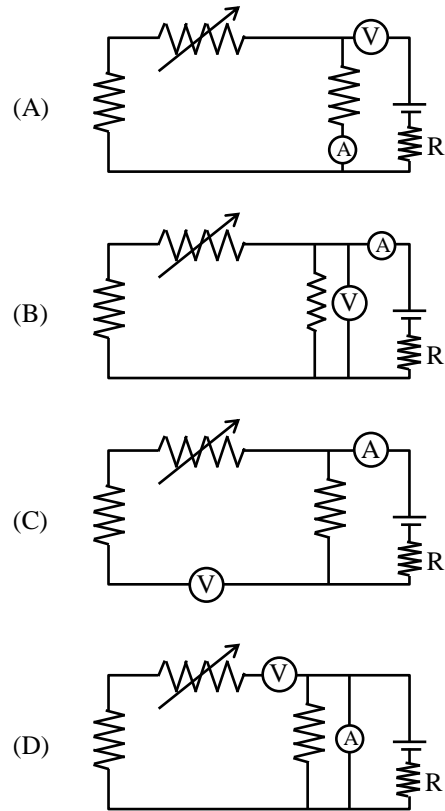

[B]

- Q.10** In this given circuit, no current is passing through the galvanometer. If the cross-sectional diameter of the wire AB is doubled then for null point of galvanometer the value of AC would— [IIT -JEE 2003]

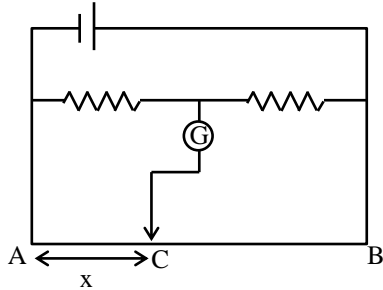

- (A)  $x/4$  (B)  $4x$   
(C)  $2x$  (D)  $x$  [D]

- Q.11** In the given post office box. Unknown resistance should be connected [IIT- JEE 2004]

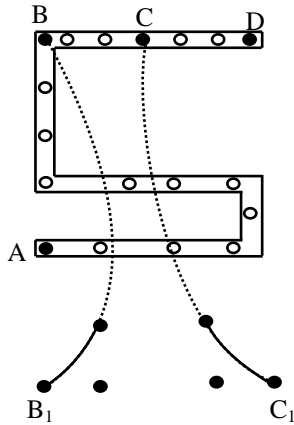

- (A) Between A & D  
(B) Between A & C  
(C) Between C & D  
(D) Between B<sub>1</sub> & C<sub>1</sub> [A]

- Q.12** A galvanometer gives a full deflection when a current of 0.2 mA is passed through it. The resistance of the galvanometer is 1000 Ω. To convert it to an ammeter of range 2 amp, the shunt resistance required is –

- (A) 0.1 Ω (B) 0.01 Ω  
(C) 1 Ω (D) 0.2 Ω [A]

- Q.13** A galvanometer of resistance 100 Ω gives a full scale deflection for a current to  $10^{-6}$  amp. To convert it into an ammeter capable of measuring up to one ampere, the shunt resistance should be—

- (A)  $10^{-5}$  Ω (B) 0.0001 Ω  
(C) 0.01 Ω (D) 1 Ω [B]

- Q.14** If the positions of an ideal voltmeter and the ammeter are interchanged in a D.C. circuit, then-

- (A) the voltmeter reads the emf of the source and the ammeter reading is zero  
(B) the voltmeter reads the emf of the source and the ammeter shows of maximum current  
(C) the voltmeter reading is zero and the ammeter reading is also zero  
(D) voltmeter reading is zero and the ammeter current is infinite [A]

- Q.15** A galvanometer is used in circuit of 9 volt. The value of current for full scale deflection is 2 mA if the resistance of the coil is 50Ω, then the value of necessary resistance in series for the full scale deflection in ohm is -

- (A) 2450 (B) 3450  
(C) 4450 (D) 5450 [C]

- Q.16** Internal electric connections of a multi range voltmeter are shown in the figure. The terminals are marked 3 volt, 5 volt, 150 volt, resistance of the galvanometer is 20 Ω and the value of current is 1 mA for the full scale deflection of the galvanometer. The resistance of R<sub>1</sub> in KΩ is-

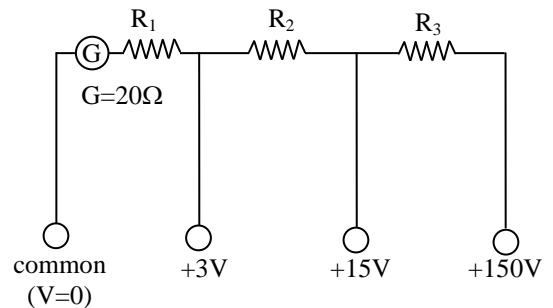

- (A) 12 (B) 15  
(C) 3 (D) 2.98 [D]

- Q.17** The resistance of galvanometer coil is 0.1 KΩ. The current for full scale deflection is 100 μA. The value of the resistance put in series to convert it into a voltmeter of range 0.1 volt is-

- (A) 1000 Ω (B) 100 Ω  
(C) 10 Ω (D) 900 Ω [D]

- Q.18** The resistance of  $100\ \Omega$  and  $200\ \Omega$  are connected in series with the  $220\ \text{V}$  mains. When a voltmeter of  $1000\ \Omega$  resistance is connected in parallel to  $100\ \Omega$ , then the reading of voltmeter is -  
 (A)  $68.75\ \text{volt}$  (B)  $6.87\ \text{volt}$   
 (C)  $587.5\ \text{volt}$  (D)  $58.75\ \text{volt}$  [A]
- Q.19** If only one hundredth part of total current flowing in the circuit is to be passed through a galvanometer of resistance  $G\ \Omega$ , then the value of shunt resistance required will be -  
 (A)  $\frac{G}{10}$  (B)  $\frac{G}{100}$   
 (C)  $\frac{G}{99}$  (D)  $\frac{G}{999}$  [C]
- Q.20** The shunt required for 10% of main current to be sent through the moving coil galvanometer of resistance  $99\ \Omega$ , will be -  
 (A)  $0.9\ \Omega$  (B)  $11\ \Omega$   
 (C)  $90\ \Omega$  (D)  $9.9\ \Omega$  [B]
- Q.21** A galvanometer of resistance  $100\ \Omega$  gives full scale deflection for  $10\ \text{mA}$  current. What should be the shunt required, so that it can measure  $100\ \text{mA}$  -  
 (A)  $11.11\ \Omega$  (B)  $9.9\ \Omega$   
 (C)  $1.1\ \Omega$  (D)  $4.4\ \Omega$  [A]
- Q.22** A galvanometer of resistance  $100\ \Omega$  gives full scale deflection for a current of  $10^{-5}\ \text{A}$ . The shunt required to convert it into an ammeter of  $1\ \text{ampere}$  range will be -  
 (A)  $10^{-2}\ \Omega$  (B)  $1\ \Omega$   
 (C)  $10^{-1}\ \Omega$  (D)  $10^{-3}\ \Omega$  [D]
- Q.23** A galvanometer of resistance  $100\ \text{ohm}$  gives a full scale deflection for a current of  $10\ \mu\text{A}$ . To convert it into an ammeter of one ampere range, required shunt resistance would be -  
 (A)  $10^{-2}\ \Omega$  (B)  $1\ \Omega$   
 (C)  $10^{-1}\ \Omega$  (D)  $10^{-3}\ \Omega$  [D]
- Q.24** The deflection in the galvanometer is reduced from 50 to 20 divisions when it is shunted by a resistance of  $12\ \text{ohm}$ . The resistance of galvanometer will be -  
 (A)  $18\ \Omega$  (B)  $24\ \Omega$   
 (C)  $30\ \Omega$  (D)  $36\ \Omega$  [A]
- Q.25** The resistance of a moving coil galvanometer is  $20\ \Omega$ . It requires  $0.01\ \text{ampere}$  current for full scale deflection. The value of resistance to convert it into a voltmeter of range  $20\ \text{volt}$  will be -  
 (A)  $198\ \Omega$  (B)  $1980\ \Omega$   
 (C)  $20\ \Omega$  (D)  $0\ \Omega$  [B]
- Q.26** The range of a voltmeter of resistance  $G\ \Omega$  is  $V\ \text{volt}$ . The resistance required to be connected in series with it in order to convert it into a voltmeter of range  $nV\ \text{volt}$ , will be -  
 (A)  $(n - 1)G$  (B)  $G/n$   
 (C)  $nG$  (D)  $G/(n - 1)$  [A]
- Q.27** The deflection of a moving coil galvanometer reduces to half on shunting it with a resistance of  $60\ \Omega$ . The resistance of galvanometer is -  
 (A)  $30\ \Omega$  (B)  $120\ \Omega$   
 (C)  $60\ \Omega$  (D)  $15\ \Omega$  [C]
- Q.28** When the current flowing in a galvanometer is  $(1/n)$  of the total current, the resistance of the shunt will be -  
 (A)  $G/n$  (B)  $(n - 1)G$   
 (C)  $G/(n - 1)$  (D)  $G/(n^2 - 1)$  [C]
- Q.29** A galvanometer can be converted into a voltmeter by connecting a -  
 (A) high resistance in parallel  
 (B) low resistance in series  
 (C) high resistance in series  
 (D) low resistance in parallel [C]
- Q.30** Potentiometer is such an apparatus whose effective resistance is -  
 (A) zero  
 (B) infinite  
 (C) uncertain  
 (D) depending on external resistance [B]
- Q.31** In every experiment with potentiometer in the null point state, the potential difference between the ends of the galvanometer is -  
 (A) zero  
 (B) infinite  
 (C) equal to the p.d. of the cell  
 (D) unknown [A]

- Q.32** The specific resistance per unit area of cross section of a wire is equivalent to -  
 (A) charge/current  
 (B) resistance/length  
 (C) potential gradient  
 (D) current/area [B]
- Q.33** If the length of the potentiometer wire is doubled, the sensitivity for obtaining null point will -  
 (A) increase  
 (B) remain unchanged  
 (C) decrease  
 (D) uncertain [A]
- Q.34** The potential gradient of the potentiometer wire depends on -  
 (A) only on the current that flows  
 (B) only the resistance per unit length of the wire  
 (C) both the above mentioned  
 (D) none of the above [C]
- Q.35** The potentiometer wire is replaced by another wire whose length thickness and specific resistance are double the previous one. The current strength flowing through it is also doubled. How many times will the potential gradient becomes ?  
 (A) 1 (B) 2  
 (C) 4 (D) 8 [A]
- Q.36** If the current in a potentiometer increases, the position of the null point will -  
 (A) be obtained at a larger than the previous one  
 (B) be equal to the previous length  
 (C) be obtained at a smaller length than the previous  
 (D) none of the above [C]
- Q.37** A battery of negligible internal resistance is connected to the ends of a potentiometer wire. The potential gradient can be changed by ( $r = R' = 0$  for wire) -  
 (A) increasing the length of wire  
 (B) increasing the thickness of wire  
 (C) changing the direction of the current  
 (D) increasing its resistance [A]
- Q.38** The length of a potentiometer wire is 10 m and a p.d. of 2 volt is applied to its ends. If the length of its wire is increased by 1 m, the value of potential gradient in volt/m will be -  
 (A) 0.18 (B) 0.22  
 (C) 1.3 (D) 0.9 [A]
- Q.39** If the specific resistance of a potentiometer is ( $\rho$ ) area of cross-section is A, and the current flowing in the wire is (I) then the potential gradient is -  
 (A)  $IA\rho$  (B)  $IA/\rho$   
 (C)  $I\rho/A$  (D)  $\rho/IA$  [C]
- Q.40** The potentiometer is an ideal apparatus for measuring potential differences because -  
 (A) its resistance is low  
 (B) at null position its resistance is zero  
 (C) its range is adjustable  
 (D) it does not draw any current when measuring p.d. [D]
- Q.41** A potentiometer is based on the principle -  
 (A) of wheatstone bridge  
 (B) that the fall of potential along a wire is proportional to its lengths  
 (C) that the resistance of potentiometer wire is large  
 (D) of post office box [B]
- Q.42** If the length of the potentiometer wire is increased, the sensitivity will -  
 (A) increase  
 (B) decrease  
 (C) be same  
 (D) none of the above [A]
- Q.43** In an ammeter calibration experiment, the potentiometer is used to measure in the secondary circuit, the -  
 (A) resistance  
 (B) potential difference  
 (C) current  
 (D) power [B]

- Q.44** In potentiometer the potential gradient is -  
 (A) resistance across the unit length of the wire  
 (B) current across the unit length of the wire  
 (C) potential difference across the unit length of the wire  
 (D) power across the unit length of the wire [C]
- Q.45** If the potentiometer wire having resistance  $\rho$  ohm/m and I amp. current is allowed to pass through it. The potential gradient produced on the potentiometer wire will be -  
 (A)  $I/\rho$  (B)  $I\rho$   
 (C)  $\rho/I$  (D)  $I^2\rho$  [B]
- Q.46** The principal of a potentiometer is -  
 (A) to compare two unknown resistances  
 (B) to compare two known resistance  
 (C) to find out unknown p.d. by comparing it with known p.d.  
 (D) to calibrate a voltmeter [C]
- Q.47** The wire of potentiometer is made of -  
 (A) copper (B) steel  
 (C) manganin (D) aluminium [C]
- Q.48** If the current in the primary circuit of a potentiometer wire of specific resistance is  $40 \times 10^{-8}\Omega\text{-m}$  and area of cross-section  $8 \times 10^{-6}\text{m}^2$  is 0.5 amp. Then potential gradient of wire is -  
 (A) 25mV/m (B) 2.5mV/m  
 (C) 2.5mV/m (D) 25V/m [A]
- Q.49** A cell of emf E and internal resistance r is balanced at length  $\ell$  of a potentiometer wire. If another resistance R is connected in parallel with this, the new balancing length will be -  
 (A)  $\frac{R}{R-r}\ell$  (B)  $\frac{R-r}{R}\ell$   
 (C)  $\frac{R}{r}\ell$  (D)  $\frac{R}{R+r}\ell$  [D]
- Q.50** The balancing length for a 1.2 volts cell of 5 ohm internal resistance is 900 cm. If a resistance of 10 ohm is connected to the terminals of the cell, the p.d. and balancing length at the ends of resistance will be -  
 (A) 0.8 volt, 600 cm (B) 0.3 volt, 300 cm  
 (C) 0.24 volt, 130 cm (D) 0.12 volt, 90 cm [A]