

**SECTION-A**

1. If  $\gcd(m, n) = 1$  and  
 $1^2 - 2^2 + 3^2 - 4^2 + \dots + (2021)^2 - (2022)^2 + (2023)^2 = 1012 m^2 n$   
 then  $m^2 - n^2$  is equal to :

- (1) 180                      (2) 220                      (3) 200                      (4) 240

**Sol.** (4)  
 $(1 - 2)(1 + 2) + (3 - 4)(3 + 4) + \dots + (2021 - 2022)(2021 + 2022) + (2023)^2 = (1012) m^2 n$   
 $\Rightarrow (-1)[1 + 2 + 3 + 4 + \dots + 2022] + (2023)^2 = (1012) m^2 n$   
 $\Rightarrow (-1) \frac{(2022)(2023)}{2} + (2023)^2 = (1012) m^2 n$   
 $\Rightarrow (2023)[2023 - 1011] = (1012) m^2 n$   
 $\Rightarrow (2023)(1012) = (1012) m^2 n$   
 $\Rightarrow m^2 n = 2023$   
 $\Rightarrow m^2 n = (17)^2 \times 7$   
 $m = 17, n = 7$   
 $m^2 - n^2 = (17)^2 - 7^2 = 289 - 49 = 240$   
 Ans. Option 4

2. The area bounded by the curves  $y = |x - 1| + |x - 2|$  and  $y = 3$  is equal to :

- (1) 5                      (2) 4                      (3) 6                      (4) 3

**Sol.** (2)  
 $y = |x - 1| + |x - 2|$

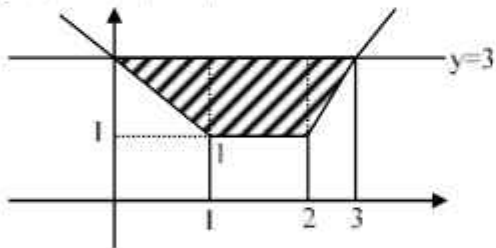

$$A = \frac{1}{2} [1+3] [2]$$

$$= 4$$

Ans. Option 2

3. For the system of equations  
 $x + y + z = 6$   
 $x + 2y + \alpha z = 10$   
 $x + 3y + 5z = \beta$ , which one of the following is NOT true :

- (1) System has a unique solution for  $\alpha = 3, \beta \neq 14$ .  
 (2) System has a unique solution for  $\alpha = -3, \beta = 14$ .  
 (3) System has no solution for  $\alpha = 3, \beta = 24$ .  
 (4) System has infinitely many solutions for  $\alpha = 3, \beta = 14$ .

**Sol.** (1)  
 $\Delta = \begin{vmatrix} 1 & 1 & 1 \\ 1 & 2 & \alpha \\ 1 & 3 & 5 \end{vmatrix}$

$$= (10 - 3\alpha) - (5 - \alpha) + (3 - 2)$$

$$= 6 - 2\alpha$$

$$\Delta x = \begin{vmatrix} 6 & 1 & 1 \\ 10 & 2 & \alpha \\ \beta & 3 & 5 \end{vmatrix}$$

$$= 6(10 - 3\alpha) - (50 - \alpha 13) + (30 - 2\beta)$$

$$= 40 - 18\alpha + \alpha\beta - 2\beta$$

$$\Delta y = \begin{vmatrix} 1 & 6 & 1 \\ 1 & 10 & \alpha \\ 1 & \beta & 5 \end{vmatrix}$$

$$= (50 - \alpha\beta) - 6(5 - \alpha) + (\beta - 10)$$

$$= 10 + 6\alpha + \beta - \alpha\beta$$

$$\Delta z = \begin{vmatrix} 1 & 1 & 6 \\ 1 & 2 & 10 \\ 1 & 3 & \beta \end{vmatrix}$$

$$= (2\beta - 30) - (\beta - 10) + 6(1)$$

$$= \beta - 14$$

for Infinite solution  $\Delta = 0, \Delta_x = \Delta_y = \Delta_z = 0$

$$\alpha = 3, \beta = 14$$

For unique solution  $\alpha \neq 3$

Ans. Option 1

4. Among the statements :

(S1):  $(p \Rightarrow q) \vee ((\sim p) \wedge q)$  is a tautology

(S2):  $(q \Rightarrow p) \Rightarrow ((\sim p) \wedge q)$  is a contradiction

(1) only (S2) is True

(2) only (S1) is True

(3) neither (S1) and (S2) is True

(4) both (S1) and (S2) are True

Sol. (3)

S1

P	Q	$\sim p$	$\sim p \wedge q$	$p \Rightarrow q$	$(p \Rightarrow q) \vee (\sim p \wedge q)$
T	T	F	F	T	T
T	F	F	F	F	F
F	T	T	T	T	T
F	F	T	F	T	T

S2

P	Q	$q \Rightarrow p$	$\sim p$	$(\sim p) \wedge q$	$(q \Rightarrow p) \Rightarrow (\sim p \wedge q)$
T	T	T	F	F	F
T	F	T	F	F	F
F	T	F	T	T	T
F	F	T	T	F	F

Ans. Option 3

5.  $\lim_{n \rightarrow \infty} \left\{ \left( 2^{\frac{1}{2}} - 2^{\frac{1}{3}} \right) \left( 2^{\frac{1}{2}} - 2^{\frac{1}{3}} \right) \dots \left( 2^{\frac{1}{2}} - 2^{\frac{1}{2n+1}} \right) \right\}$  is equal to

(1)  $\frac{1}{\sqrt{2}}$

(2)  $\sqrt{2}$

(3) 1

(4) 0

Sol. (4)

$$P = \lim_{n \rightarrow \infty} \left( 2^{\frac{1}{2}} - 2^{\frac{1}{3}} \right) \left( 2^{\frac{1}{2}} - 2^{\frac{1}{5}} \right) \dots \left( 2^{\frac{1}{2}} - 2^{\frac{1}{2n+1}} \right)$$

Let

$$2^{\frac{1}{2}} - 2^{\frac{1}{3}} \rightarrow \text{Smallest}$$

$$2^{\frac{1}{2}} - 2^{\frac{1}{2n+1}} \rightarrow \text{Largest}$$

Sandwich th.

$$\left( 2^{\frac{1}{2}} - 2^{\frac{1}{3}} \right)^n \leq P \leq \left( 2^{\frac{1}{2}} - 2^{\frac{1}{2n+1}} \right)^n$$

$$\left( \text{lie b/w} \right)^n$$

$$(0 \text{ and } 1)$$

$$\lim_{n \rightarrow \infty} \left( 2^{\frac{1}{2}} - 2^{\frac{1}{3}} \right)^n = 0$$

$$\lim_{n \rightarrow \infty} \left( 2^{\frac{1}{2}} - 2^{\frac{1}{2n+1}} \right)^n = 0$$

$$\therefore P = 0$$

6. Let  $P$  be a square matrix such that  $P^2 = I - P$ . For  $\alpha, \beta, \gamma, \delta \in \mathbb{N}$ , if  $P^\alpha + P^\beta = \gamma I - 29P$  and  $P^\alpha - P^\beta = \delta I - 13P$ , then  $\alpha + \beta + \gamma - \delta$  is equal to :

- (1) 40                      (2) 22                      (3) 24                      (4) 18

Sol. (3)

$$P^2 = I - P$$

$$P^\alpha + P^\beta = \gamma I - 29P$$

$$P^\alpha - P^\beta = \delta I - 13P$$

$$P^4 = (I - P)^2 = I + P^2 - 2P$$

$$P^4 = I + I - P - 2P = 2I - 3P$$

$$P^8 = (P^4)^2 = (2I - 3P)^2 = 4I + 9P^2 - 12P$$

$$= 4I + 9(I - P) - 12P$$

$$P^8 = 13I - 21P \quad \dots(1)$$

$$P^6 = P^4 P^2 = (2I - 3P)(I - P)$$

$$= 2I - 5P + 3P^2$$

$$= 2I - 5P + 3(I - P)$$

$$= 5I - 8P \quad \dots(2)$$

$$(1) + (2) \quad \quad \quad (1) - (2)$$

$$P^8 + P^6 = 18I - 29P \quad \quad \quad \boxed{P^8 - P^6 = 8I - 13P}$$

From (A)       $\alpha = 8, \beta = 6$

$$\gamma = 18$$

$$\delta = 8$$

$$\alpha + \beta + \gamma - \delta = 32 - 8 = 24$$

7. A plane  $P$  contains the line of intersection of the plane  $\vec{r} \cdot (\hat{i} + \hat{j} + \hat{k}) = 6$  and  $\vec{r} \cdot (2\hat{i} + 3\hat{j} + 4\hat{k}) = -5$ . If  $P$  passes through the point  $(0, 2, -2)$ , then the square of distance of the point  $(12, 12, 18)$  from the plane  $P$  is :

- (1) 620                      (2) 1240                      (3) 310                      (4) 155

Sol. (1)

eq<sup>n</sup> of plane       $P_1 + \lambda P_2 = 0$

$$(x + y + z - 6) + \lambda (2x + 3y + 4z + 5) = 0$$

pass th. (0, 2, -2)

$$(-6) + \lambda (6 - 8 + 5) = 0$$

$$(-6) + \lambda [3] = 0 \quad \Rightarrow \lambda = 2$$

eq<sup>n</sup> of plane

$$5x + 7y + 9z + 4 = 0$$

distance from (12, 12, 18)

$$d = \frac{|60 + 84 + 162 + 4|}{\sqrt{25 + 49 + 81}}$$

$$d = \frac{310}{\sqrt{155}}$$

$$d^2 = \frac{310 \times 310}{155}$$

$$\boxed{d^2 = 620}$$

Ans. Option 1

8. Let  $f(x)$  be a function satisfying  $f(x) + f(\pi - x) = \pi^2$ ,  $\forall x \in \mathbb{R}$ . Then  $\int_0^\pi f(x) \sin x \, dx$  is equal to :

(1)  $\frac{\pi^2}{2}$

(2)  $\pi^2$

(3)  $2\pi^2$

(4)  $\frac{\pi^2}{4}$

Sol. (2)

$$I = \int_0^\pi f(x) \sin x \, dx \quad \dots\dots(1)$$

Apply king property

$$I = \int_0^\pi f(\pi - x) \sin(\pi - x) \, dx \quad \dots\dots(1)$$

Add

$$2I = \int_0^\pi f(x) + f(\pi - x) \sin x \, dx$$

$$2I = \int_0^\pi \pi^2 \sin x \, dx$$

$$2I = \pi^2 (2)$$

$$\boxed{I = \pi^2}$$

Ans. Option 2

9. If the coefficients of  $x^7$  in  $\left(ax^2 + \frac{1}{2bx}\right)^{11}$  and  $x^7$  in  $\left(ax - \frac{1}{3bx^2}\right)^{11}$  are equal, then :

(1)  $64 ab = 243$

(2)  $32 ab = 729$

(3)  $729 ab = 32$

(4)  $243 ab = 64$

Sol. (3)

$$\left(ax^2 + \frac{1}{2bx}\right)^{11}$$

$$r = \frac{11 \times 2 - 7}{3} = 5$$

$$\text{Coefficient of } x^7 \text{ is } = {}^{11}C_5 (a)^6 \left(\frac{1}{2b}\right)^5$$

$$\left(ax - \frac{1}{3bx^2}\right)^{11}$$

$$r = \frac{11 \times 1 - (-7)}{3} = 6$$

$$\text{Coefficient of } x^{-7} \text{ is } = {}^{11}C_6 \cdot \frac{a^5}{3^6 b^6}$$

$$\therefore {}^{11}C_5 (a^6) \left(\frac{1}{2^5 b^5}\right) = {}^{11}C_6 \cdot \frac{a^5}{3^6 b^6}$$

$$\Rightarrow ab = \frac{2^5}{3^6}$$

$$\Rightarrow \boxed{729 ab = 32}$$

Ans. Option 3

10. If the tangents at the points P and Q are the circle  $x^2 + y^2 - 2x + y = 5$  meet at the point  $R\left(\frac{9}{4}, 2\right)$ , then the area of the triangle PQR is :

(1)  $\frac{5}{4}$

(2)  $\frac{13}{4}$

(3)  $\frac{5}{8}$

(4)  $\frac{13}{8}$

Sol.

(3)  
 $x^2 + y^2 - 2x + y = 5$

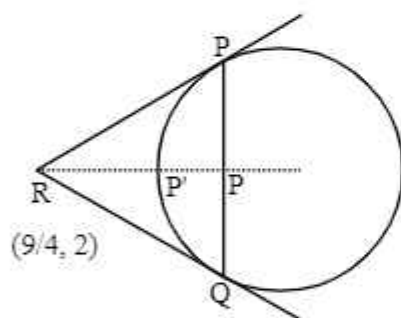

with respect to R PQ is C.O.C

eq<sup>n</sup> of C.O.C is  $T = 0$

$$\frac{9}{4}x + 2y - \left(x + \frac{9}{4}\right) + \frac{1}{2}(y + 2) - 5 = 0$$

$$\frac{5}{4}x + \frac{5}{2}y - \frac{25}{4} = 0$$

$$5x + 10y - 25 = 0$$

$$\boxed{x + 2y = 5}$$

$$\text{Area} = \frac{1}{2}(P')(PQ)$$

$$= \frac{1}{2} \left[ \frac{\sqrt{5}}{4} \right] (\sqrt{5})$$

$$= \frac{5}{8}$$

$$(PQ) = 2\sqrt{r^2 - p^2} = \sqrt{5}$$

$$P' = \frac{\frac{9}{4} + 4 - 5}{\sqrt{5}}$$

$$= \left( \frac{5}{4\sqrt{5}} \right) = \frac{\sqrt{5}}{4}$$

Method II

$$\text{area} = \frac{RL^4}{R^2 + L^2}$$

$$R = \frac{5}{2}$$

$$L = \sqrt{\frac{81}{16} + 4 - \frac{9}{2} + 2 - 5}$$

$$= \frac{5}{4}$$

$$\text{area} = \frac{5}{8}$$

Ans. Option 3

11. Three dice are rolled. If the probability of getting different numbers on the three dice is  $\frac{p}{q}$ , where p and q are

co-prime, then q - p is equal to :

- (1) 1                      (2) 2                      (3) 4                      (4) 3

Sol. (3)

$$\text{Fav.} = \frac{{}^6C_3(3!)}{6 \times 6 \times 6}$$

$$= \frac{(20)(6)}{6 \cdot 6 \cdot 6} = \frac{20}{36} = \frac{5}{9} = \frac{p}{q}$$

$$\left. \begin{array}{l} p = 5 \\ q = 9 \end{array} \right\} \Rightarrow \boxed{q - p = 4}$$

Ans. Option 3

12. In a group of 100 persons 75 speak English and 40 speak Hindi. Each person speaks at least one of the two languages. If the number of persons, who speak only English is  $\alpha$  and the number of persons who speak only Hindi is  $\beta$ , then the eccentricity of the ellipse  $25(\beta^2x^2 + \alpha^2y^2) = \alpha^2\beta^2$  is :

- (1)  $\frac{\sqrt{129}}{12}$                       (2)  $\frac{\sqrt{117}}{12}$                       (3)  $\frac{\sqrt{119}}{12}$                       (4)  $\frac{3\sqrt{15}}{12}$

Sol. (3)

$$n(A \cup B) = n(A) + n(B) - n(A \cap B)$$

$$n(A \cap B) = 75 + 40 - 100$$

$$n(A \cap B) = 15$$

$$\text{Only E} \rightarrow 60 \qquad \alpha = 60$$

$$\text{Only H} \rightarrow 25 \qquad \beta = 25$$

$$\text{Both} = 15$$

$$\frac{25x^2}{\alpha^2} + \frac{25y^2}{\beta^2} = 1$$

$$\frac{25x^2}{(60)^2} + \frac{(25y^2)}{(25)^2} = 1$$

$$e^2 = 1 - \left[ \frac{25 \times 25}{(60)^2} \right]$$

$$e^2 = \frac{(60)^2 - (25)^2}{(60)^2}$$

$$e^2 = \frac{(60-25)(60+25)}{60 \times 60}$$

$$e^2 = \frac{(35)(85)}{60 \times 60} = \frac{119}{144}$$

$$e = \frac{\sqrt{119}}{12}$$

13. If the solution curve  $f(x, y) = 0$  of the differential equation  $(1 + \log_e x) \frac{dx}{dy} - x \log_e x = e^y, x > 0$ , passes through the points  $(1, 0)$  and  $(\alpha, 2)$ , then  $\alpha^\alpha$  is equal to :

- (1)  $e^{\sqrt{2}e^2}$                       (2)  $e^{e^2}$                       (3)  $e^{2e^2}$                       (4)  $e^{2e}$

Sol. (4)

$$(1 + \log_e x) \frac{dx}{dy} - x \log_e x = e^y$$

Let  $x \log_e x = t$

$$(1 + \log_e x) \frac{dx}{dy} = \frac{dt}{dy}$$

$$\frac{dt}{dy} - t = e^y$$

$$P = -1, Q = e^y$$

$$I.F = e^{\int -1 dy} = e^{-y}$$

Solution -

$$(t)(e^{-y}) = \int (e^{-y})(e^y) dy$$

$$t(e^{-y}) = y + c$$

$$(x \log_e x) e^{-y} = y + c$$

$$\Rightarrow \text{pass } (1, 0) \Rightarrow c = 0$$

$$\text{pass } (\alpha, 2)$$

$$\boxed{\alpha^\alpha = e^{2e^2}}$$

Ans. Option 4

14. Let the sets A and B denote the domain and range respectively of the function  $f(x) = \frac{1}{\sqrt{[x] - x}}$ , where  $[x]$

denotes the smallest integer greater than or equal to x. Then among the statements :

(S1) :  $A \cap B = (1, \infty) - \mathbb{N}$  and

(S2) :  $A \cup B = (1, \infty)$

(1) only (S1) is true

(2) neither (S1) nor (S2) is true

(3) only (S2) is true

(4) both (S1) and (S2) are true

Sol. (1)

$$f(x) = \frac{1}{\sqrt{[x] - x}}$$

If  $x \in I[x] = [x]$  (greatest integer function)

If  $x \notin I[x] = [x] + 1$

$$\Rightarrow f(x) = \begin{cases} \frac{1}{\sqrt{[x]-x}}, x \in I \\ \frac{1}{\sqrt{[x]+1-x}}, x \notin I \end{cases}$$

$$\Rightarrow f(x) = \begin{cases} \frac{1}{\sqrt{-\{x\}}}, x \in I, (\text{does not exist}) \\ \frac{1}{\sqrt{1-\{x\}}}, x \notin I \end{cases}$$

$\Rightarrow$  domain of  $f(x) = \mathbb{R} - I$

Now,  $f(x) = \frac{1}{\sqrt{1-\{x\}}}, x \notin I$

$\Rightarrow x < \{x\} < 1$

$\Rightarrow 0 < 1 - \sqrt{1-\{x\}} < 1$

$\Rightarrow \frac{1}{\sqrt{1-\{x\}}} > 1$

$\Rightarrow$  Range  $(1, \infty)$

$\Rightarrow A = \mathbb{R} - I$

$B = (1, \infty)$

So,  $A \cap B = (1, \infty) - \mathbb{N}$

$A \cup B = (1, \infty)$

$\Rightarrow$  S1 is only correct.

15. Let  $a \neq b$  be two-zero real numbers. Then the number of elements in the set  $X = \{z \in \mathbb{C} : \operatorname{Re}(az^2 + bz) = a \text{ and } \operatorname{Re}(bz^2 + az) = b\}$  is equal to :

(1) 0

(2) 2

(3) 1

(4) 3

Sol. (1) Bonus

$\because z + \bar{z} = 2\operatorname{Re}(z)$       If  $z = x + iy$        $\Rightarrow z + \bar{z} = 2x$        $z^2 + (\bar{z})^2 = 2(x^2 - y^2)$

$(az^2 + bz) + (a\bar{z}^2 + b\bar{z}) = 2a$       .....(1)

$(bz^2 + az) + (b\bar{z}^2 + a\bar{z}) = 2b$       .....(2)

add (1) and (2)

$(a+b)z^2 + (a+b)z + (a+b)\bar{z}^2 + (a+b)\bar{z} = 2(a+b)$

$(a+b)[z^2 + z + (\bar{z})^2 + \bar{z}] = 2(a+b)$       .....(3)

sub. (1) and (2)

$(a-b)[z^2 - z + \bar{z}^2 - \bar{z}] = 2(a-b)$       .....(4)

$z^2 + \bar{z}^2 - z - \bar{z} = 2$

Case I: If  $a + b \neq 0$

From (3) & (4)

$2x + 2(x^2 - y^2) = 2 \Rightarrow x^2 - y^2 + x = 1$       .....(5)

$2(x^2 - y^2) - 2x = 2 \Rightarrow x^2 - y^2 - x = 1$       .....(6)

(5) - (6)

$2x = 0 \Rightarrow x = 0$

from (5)       $y^2 = -1 \Rightarrow$  not possible

$\therefore$  Ans = 0

Case II: If  $a + b = 0$  then infinite number of solution.

So, the set X have infinite number of elements.



16. The sum of all values of  $\alpha$ , for which the points whose position vectors are  $\hat{i} - 2\hat{j} + 3\hat{k}$ ,  $2\hat{i} - 3\hat{j} + 4\hat{k}$ ,  $(\alpha + 1)\hat{i} + 2\hat{k}$  and  $9\hat{i} + (\alpha - 8)\hat{j} + 6\hat{k}$  are coplanar, is equal to :

- (1) -2                      (2) 2                      (3) 6                      (4) 4

Sol. (2)

$$\left. \begin{array}{l} A = (1, -2, 3) \\ B = (2, -3, 4) \\ C = (\alpha + 1, 0, 2) \\ D = (9, \alpha - 8, 6) \end{array} \right\} \\ \left[ \begin{array}{ccc} \vec{AB} & \vec{AC} & \vec{AD} \end{array} \right] = 0 \\ \left| \begin{array}{ccc} 1 & -1 & 1 \\ \alpha & 2 & -1 \\ 8 & \alpha - 6 & 3 \end{array} \right| = 0$$

$$\Rightarrow (6 + \alpha - 6) + 1(3\alpha + 8) + (\alpha^2 - 6\alpha - 16) = 0$$

$$\Rightarrow \alpha^2 - 2\alpha - 8 = 0$$

$$\Rightarrow \alpha = 4, -2$$

$$\Rightarrow \text{sum of all values of } \alpha = 2$$

Ans. option 2

17. Let the line L pass through the point  $(0, 1, 2)$ , intersect the line  $\frac{x-1}{2} = \frac{y-2}{3} = \frac{z-3}{4}$  and be parallel to the plane  $2x + y - 3z = 4$ . Then the distance of the point  $P(1, -9, 2)$  from the line L is :

- (1) 9                      (2)  $\sqrt{54}$                       (3)  $\sqrt{69}$                       (4)  $\sqrt{74}$

Sol. (4)

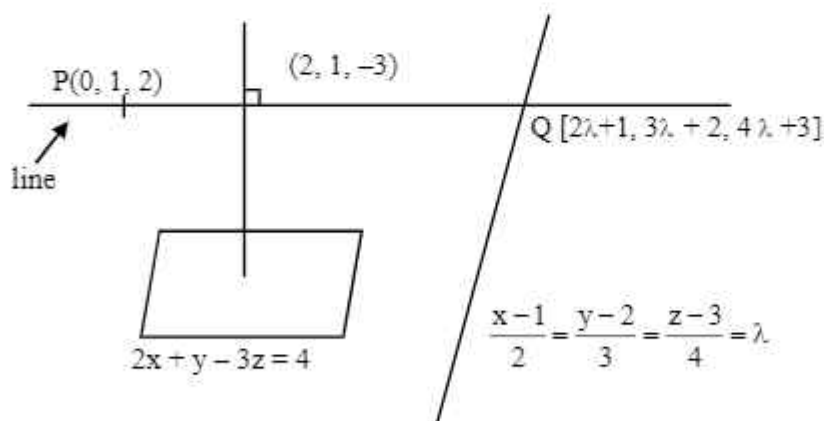

$$\vec{PQ} = (2\lambda + 1, 3\lambda + 1, 4\lambda + 1)$$

$$\vec{PQ} \cdot \vec{n} = 0 \Rightarrow (2\lambda + 1)(2) + (3\lambda + 1)(1) + (4\lambda + 1)(-3) = 0$$

$$\Rightarrow -5\lambda = 0$$

$$\Rightarrow \lambda = 0$$

$$Q = (1, 2, 3)$$

eq<sup>n</sup> of line

$$\frac{x-0}{1} = \frac{y-1}{1} = \frac{z-2}{1} = \mu$$

distance of line from  $(1, -9, 2)$

$$(PQ) \cdot (1, 1, 1) = 0$$

$$\Rightarrow [\mu - 1, \mu + 10, \mu] \cdot [1, 1, 1] = 0$$

$$\Rightarrow \mu - 1 + \mu + 10 + \mu = 0$$

$$\mu = -3$$

$$Q' = (-3, -2, 1)$$

$$PQ = \sqrt{16 + 49 + 9} = \sqrt{74}$$

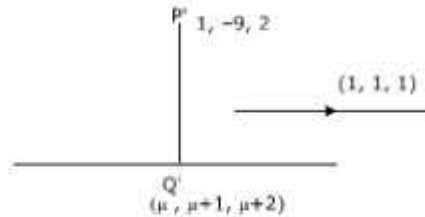

18. All the letters of the word PUBLIC are written in all possible orders and these words are written as in a dictionary with serial numbers. Then the serial number of the word PUBLIC is :

(1) 580

(2) 578

(3) 576

(4) 582

Sol. (4)

$$B \text{ ————— } = 5! = 120$$

$$C \text{ ————— } = 5! = 120$$

$$I \text{ ————— } = 5! = 120$$

$$L \text{ ————— } = 5! = 120$$

$$PB \text{ ————— } = 4! = 24$$

$$PC \text{ ————— } = 4! = 24$$

$$PI \text{ ————— } = 4! = 24$$

$$PL \text{ ————— } = 4! = 24$$

$$PUBC \text{ ————— } = 2! = 2$$

$$PUBI \text{ ————— } = 2! = 2$$

$$PUBLC \text{ ————— } = 1$$

$$PUBLIC \text{ ————— } = 1$$

582

Rank = 582

Ans. Option 4

19. Let the vectors  $\vec{a}, \vec{b}, \vec{c}$  represent three coterminal edges of a parallelepiped of volume  $V$ . Then the volume of the parallelepiped, whose coterminal edges are represented by  $\vec{a}, \vec{b} + \vec{c}$  and  $\vec{a} + 2\vec{b} + 3\vec{c}$  is equal to :

(1)  $2V$

(2)  $6V$

(3)  $3V$

(4)  $V$

Sol. (4)

$$v = [\vec{a} \ \vec{b} \ \vec{c}]$$

$$v_1 = [\vec{a} \ \vec{b} + \vec{c} \ \vec{a} + 2\vec{b} + 3\vec{c}]$$

$$v_1 = \begin{vmatrix} 1 & 0 & 0 \\ 0 & 1 & 1 \\ 1 & 2 & 3 \end{vmatrix} [\vec{a} \ \vec{b} \ \vec{c}]$$

$$v_1 = (3-2)v$$

$$= v$$

Ans. Option 4

20. Among the statements :

(S1) :  $2023^{2022} - 1999^{2022}$  is divisible by 8

(S2) :  $13(13)^n - 11n - 13$  is divisible by 144 for infinitely many  $n \in \mathbb{N}$

(1) only (S2) is correct

(2) only (S1) is correct

(3) both (S1) and (S2) are incorrect

(4) both (S1) and (S2) are correct

Sol. (4)

$$\therefore x^n - y^n = (x - y) [x^{n-1} + x^{n-2}y + x^{n-3}y^2 + \dots + y^{n-1}]$$

$x^n - y^n$  is divisible by  $x - y$

$$\text{Stat 1} \rightarrow (2023)^{2022} - (1999)^{2022} \\ (2023) - (1999) = 24$$

$$\therefore (2023)^{2022} - (1999)^{2022} \\ \text{is divisible by 8}$$

$$\text{Stat 2} \rightarrow 13(1 + 12)^n - 11n - 13 \\ 13[1 + {}^nC_1(12) + {}^nC_2(12)^2 + \dots] - 11n - 13 \\ \Rightarrow (156n - 11n) + 13 \cdot {}^nC_2(12)^2 + 13 \cdot {}^nC_3(12)^3 + \dots \\ \Rightarrow 145n + 13 \cdot {}^nC_2(12)^2 + 13 \cdot {}^nC_3(12)^3 + \dots$$

If  $(n = 144m, m \in \mathbb{N})$  then it is divisible by 144 for infinite values of  $n$ .

Ans. Option 4

### SECTION-B

21. The value of  $\tan 9^\circ - \tan 27^\circ - \tan 63^\circ + \tan 81^\circ$  is \_\_\_\_\_ :

Sol. 4

$$(\tan 9^\circ + \cot 9^\circ) - (\tan 27^\circ + \cot 27^\circ)$$

$$\frac{1}{\sin 9^\circ \cos 9^\circ} - \frac{1}{\sin 27^\circ \cos 27^\circ}$$

$$\frac{2}{\sin 18^\circ} - \frac{2}{\sin 54^\circ}$$

$$\frac{2(4)}{\sqrt{5}-1} - \frac{2(4)}{(\sqrt{5}+1)}$$

$$\frac{8(\sqrt{5}+1)}{4} - \frac{8(\sqrt{5}-1)}{4}$$

$$2[(\sqrt{5}+1) - (\sqrt{5}-1)]$$

$$= 4$$

22. If  $(20)^{19} + 2(21)(20)^{18} + 3(21)^2(20)^{17} + \dots + 20(21)^{19} = k(20)^{19}$ , then  $k$  is equal to \_\_\_\_\_ :

Sol. 400

$$S = (20)^{19} + 2(21)(20)^{18} + \dots + 20(21)^{19}$$

$$\frac{21}{20}S = 21(20)^{18} + 2(21)^2(20)^{17} + \dots + (21)^{20}$$

Subtract

$$\left(1 - \frac{21}{20}\right)S = (20)^{19} + (21)(20)^{18} + (21)^2(20)^{17} + \dots + (21)^{19} - (21)^{20}$$

$$\left(\frac{-1}{20}\right)S = (20)^{19} \left[ \frac{1 - \left(\frac{21}{20}\right)^{20}}{1 - \frac{21}{20}} \right] - (21)^{20}$$

$$\left(\frac{-1}{20}\right)S = (21)^{20} - (20)^{20} - (21)^{20}$$

$$S = (20)^{21} = K (20)^{19} \text{ (given)}$$

$$K = (20)^2 = 400$$

23. Let the eccentricity of an ellipse  $\frac{x^2}{a^2} + \frac{y^2}{b^2} = 1$  is reciprocal to that of the hyperbola  $2x^2 - 2y^2 = 1$ . If the ellipse intersects the hyperbola at right angles, then square of length of the latus-rectum of the ellipse is \_\_\_\_\_.

Sol. 2

$$E: \frac{x^2}{a^2} + \frac{y^2}{b^2} = 1 \rightarrow e$$

$$H: x^2 - y^2 = \frac{1}{2} \Rightarrow e' = \sqrt{2}$$

$$\boxed{e = \frac{1}{\sqrt{2}}}$$

$$\therefore e^2 = \frac{1}{2}$$

$$1 - \frac{b^2}{a^2} = \frac{1}{2} \Rightarrow \frac{b^2}{a^2} = \frac{1}{2}$$

$$\boxed{a^2 = 2b^2}$$

E & H are at right angle

they are confocal

Focus of Hyperbola = focus of ellipse

$$\left( \pm \frac{1}{\sqrt{2}} \cdot \sqrt{2}, 0 \right) = \left( \pm \frac{a}{\sqrt{2}}, 0 \right)$$

$$\boxed{a = \sqrt{2}}$$

$$\therefore a^2 = 2b^2 \Rightarrow b^2 = 1$$

$$\text{Length of LR} = \frac{2b^2}{a} = \frac{2(1)}{\sqrt{2}}$$

$$= \sqrt{2}$$

$$\text{Square of LR} = 2$$

24. For  $\alpha, \beta, z \in \mathbb{C}$  and  $\lambda > 1$ , if  $\sqrt{\lambda - 1}$  is the radius of the circle  $|z - \alpha|^2 + |z - \beta|^2 = 2\lambda$ , then  $|\alpha - \beta|$  is equal to \_\_\_\_\_.

Sol. 2

$$|z - z_1|^2 + |z - z_2|^2 = |z_1 - z_2|^2$$

$$z_1 = \alpha, z_2 = \beta$$

$$|\alpha - \beta|^2 = 2\lambda$$

$$|\alpha - \beta| = \sqrt{2\lambda}$$

$$2r = \sqrt{2\lambda}$$

$$2\sqrt{\lambda - 1} = \sqrt{2\lambda}$$

$$\Rightarrow 4(\lambda - 1) = 2\lambda$$

$$\boxed{\lambda = 2}$$

$$\boxed{|\alpha - \beta| = 2}$$

25. Let a curve  $y = f(x)$ ,  $x \in (0, \infty)$  pass through the points  $P\left(1, \frac{3}{2}\right)$  and  $Q\left(a, \frac{1}{2}\right)$ . If the tangent at any point  $R(b, f(b))$  to the given curve cuts the y-axis at the points  $S(0, c)$  such that  $bc = 3$ , then  $(PQ)^2$  is equal to \_\_\_\_\_.
- Sol. 5

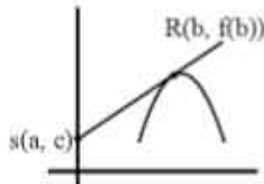

Equation of tangent at  $R(b, f(b))$  is

$$y - f(b) = f'(b)(x - b)$$

which passes through  $(0, c)$

$$\Rightarrow c - f(b) = f'(b)(-b)$$

$$\Rightarrow \frac{3}{b} - f(b) = f'(b)(-b)$$

$$\Rightarrow \frac{bf'(b) - f(b)}{b^2} = -\frac{3}{b^3}$$

$$\Rightarrow d\left(\frac{f(b)}{b}\right) = -\frac{3}{b^3} \Rightarrow \frac{f(b)}{b} = \frac{3}{2b^2} + \lambda$$

Which passes through  $(1, 3/2)$

$$\Rightarrow \frac{3}{2} = \frac{3}{2} + \lambda \Rightarrow \lambda = 0$$

$$\Rightarrow f(b) = \frac{3}{2b}$$

$$f(a) = \frac{1}{2} \Rightarrow \frac{1}{2} = \frac{3}{2b} \Rightarrow b = 3$$

$$\Rightarrow c = 1 \Rightarrow Q(3, 1/2)$$

$$\Rightarrow PQ^2 = 2^2 + (1)^2 = 5$$

26. If the lines  $\frac{x-1}{2} = \frac{2-y}{-3} = \frac{z-3}{\alpha}$  and  $\frac{x-4}{5} = \frac{y-1}{2} = \frac{z}{\beta}$  intersect, then the magnitude of the minimum value of  $8\alpha\beta$  is \_\_\_\_\_.

Sol. 18

If the lines  $\frac{x-1}{2} = \frac{2-y}{-3} = \frac{z-3}{\alpha}$  and  $\frac{x-4}{5} = \frac{y-1}{2} = \frac{z}{\beta}$  intersect Point of first line  $(1, 2, 3)$  and point on second line  $(4, 1, 0)$ .

Vector joining both points is  $-3\hat{i} + \hat{j} + 3\hat{k}$

Now vector along second line is  $2\hat{i} + 3\hat{j} + \alpha\hat{k}$

Also vector along second line is  $5\hat{i} + 2\hat{j} + \beta\hat{k}$

Now these three vectors must be coplanar

$$\Rightarrow \begin{vmatrix} 2 & 3 & \alpha \\ 5 & 2 & \beta \\ -3 & 1 & 3 \end{vmatrix}$$

$$\Rightarrow 2(6 - \beta) - 3(15 + 3\beta) + \alpha(11) = 0$$

$$\Rightarrow \alpha - \beta = 3$$

$$\text{Now } \alpha = 3 + \beta$$

$$\text{Given expression } 8(3 + \beta). \beta = 8(\beta^2 + 3\beta)$$

$$= 8\left(\beta^2 + 3\beta + \frac{9}{4} - \frac{9}{4}\right) = 8\left(\beta + \frac{3}{2}\right)^2 - 18$$

$$\text{So magnitude of minimum value} = 18$$

27. Let  $f(x) = \frac{x}{1+x^{\frac{1}{n}}}, x \in \mathbb{R} - \{-1\}, n \in \mathbb{N}, n > 2$ . If  $f^n(x) = n$  (fofof.... upto n times) (x), then

$$\lim_{n \rightarrow \infty} \int_0^1 x^{n-2} (f^n(x)) dx \text{ is equal to } \underline{\hspace{2cm}} :$$

Sol. 0

$$\text{Let } f(x) = \frac{x}{1+x^{\frac{1}{n}}}, x \in \mathbb{R} - \{-1\}, n \in \mathbb{N}, n > 2.$$

$$\text{If } f^n(x) = n \text{ (fofof.... upto n times) (x)}$$

$$\text{then } \lim_{n \rightarrow \infty} \int_0^1 x^{n-2} (f^n(x)) dx$$

$$f(f(x)) = \frac{x}{(1+2x^{\frac{1}{n}})^{\frac{1}{n}}}$$

$$f(f(f(x))) = \frac{x}{(1+3x^{\frac{1}{n}})^{\frac{1}{n}}}$$

$$\text{Similarly } f^n(x) = \frac{x}{(1+n \cdot x^{\frac{1}{n}})^{\frac{1}{n}}}$$

$$\text{Now } \lim_{n \rightarrow \infty} \int \frac{x^{n-2} \cdot x dx}{(1+n \cdot x^{\frac{1}{n}})^{\frac{1}{n}}} = \lim_{n \rightarrow \infty} \int \frac{x^{n-1} \cdot dx}{(1+n \cdot x^{\frac{1}{n}})^{\frac{1}{n}}}$$

$$\text{Now } 1 + nx^{\frac{1}{n}} = t$$

$$n^{\frac{1}{n}} \cdot x^{\frac{1}{n}-1} dx = dt$$

$$x^{n-1} dx = \frac{dt}{n^{\frac{1}{n}}}$$

$$\Rightarrow \lim_{n \rightarrow \infty} \frac{1}{n^{\frac{1}{n}}} \int_1^{1+n} \frac{dt}{t^{\frac{1}{n}}}$$

$$\Rightarrow \lim_{n \rightarrow \infty} \frac{1}{n^{\frac{1}{n}}} \left[ \frac{t^{\frac{1}{n}-1}}{\frac{1}{n}-1} \right]_1^{1+n}$$

$$\Rightarrow \lim_{n \rightarrow \infty} \frac{1}{n(n-1)} \left( (1+n)^{\frac{n-1}{n}} - 1 \right) \text{ Now let } n = \frac{1}{h}$$

$$\Rightarrow \lim_{h \rightarrow 0} \frac{\left(1 + \frac{1}{h}\right)^{1-h} - 1}{\frac{1}{h} \frac{(1-h)}{h}}$$

Using series expansion

$$\Rightarrow 0$$

28. If the mean and variance of the frequency distribution.

$x_i$	2	4	6	8	10	12	14	16
$f_i$	4	4	$\alpha$	15	8	$\beta$	4	5

are 9 and 15.08 respectively, then the value of  $\alpha^2 + \beta^2 - \alpha\beta$  is \_\_\_\_\_:

Sol. 25

$x_i$	$f_i$	$f_i x_i$	$f_i x_i^2$
2	4	8	16
4	4	16	64
6	$\alpha$	$6\alpha$	$36\alpha$
8	15	120	960
10	8	80	800
12	$\beta$	$12\beta$	$144\beta$
14	4	56	784
16	5	80	1280

$$N = \sum f_i = 40 + \alpha + \beta$$

$$\sum f_i x_i = 360 + 6\alpha + 12\beta$$

$$\sum f_i x_i^2 = 3904 + 36\alpha + 144\beta$$

$$\text{Mean } (\bar{x}) = \frac{\sum f_i x_i}{\sum f_i} = 9$$

$$\Rightarrow 360 + 6\alpha + 12\beta = 9(40 + \alpha + \beta)$$

$$3\alpha = 3\beta \Rightarrow \alpha = \beta$$

$$\sigma^2 = \frac{\sum f_i x_i^2}{\sum f_i} - \left( \frac{\sum f_i x_i}{\sum f_i} \right)^2$$

$$\Rightarrow \frac{3904 + 36\alpha + 144\beta}{40 + \alpha + \beta} - (\bar{x})^2 = 15.08$$

$$\Rightarrow \frac{3904 + 180\alpha}{40 + 2\alpha} - (9)^2 = 15.08$$

$$\Rightarrow \alpha = 5$$

$$\text{Now, } \alpha^2 + \beta^2 - \alpha\beta = \alpha^2 = 25$$

29. The number of points, where the curve  $y = x^5 - 20x^3 + 50x + 2$  crosses the x-axis is \_\_\_\_\_:

Sol. 5

$$y = x^5 - 20x^3 + 50x + 2$$

$$\frac{dy}{dx} = 5x^4 - 60x^2 + 50 = 5(x^4 - 12x^2 + 10)$$

$$\frac{dy}{dx} = 0 \Rightarrow x^4 - 12x^2 + 10 = 0$$

$$\Rightarrow x^2 = \frac{12 \pm \sqrt{144 - 40}}{2}$$

$$\Rightarrow x^2 = 6 \pm \sqrt{26} \Rightarrow x^2 \approx 6 \pm 5.1$$

$$\Rightarrow x^2 \approx 11.1, 0.9$$

$$\Rightarrow x \approx \pm 3.3, \pm 0.95$$

$$f(0) = 2, f(1) = +ve, f(2) = -ve$$

$$f(-1) = -ve, f(-2) = +ve$$

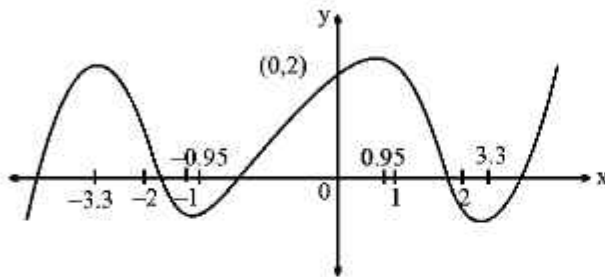

The number of points where the curve cuts the x-axis = 5.

30. The number of 4-letter words, with or without meaning, each consisting of 2 vowels and 2 consonants, which can be formed from the letters of the word UNIVERSE without repetition is \_\_\_\_\_.

Sol. 432

UNIVERSE	
Vowels	Consonant
E, E	N, V,
I, U	R, S

Case I 2 vowels different, 2 consonant different

$$({}^3C_2)({}^4C_2) (4!)$$

$$= (3) (6) (24)$$

$$= 432$$



**SECTION - A**

31. The temperature of an ideal gas is increased from 200 K to 800 K. If r.m.s. speed of gas at 200 K is  $v_0$ . Then, r.m.s. speed of the gas at 800 K will be:

- (1)  $4v_0$                       (2)  $2v_0$                       (3)  $v_0$                       (4)  $\frac{v_0}{4}$

Sol. (2)

using  $v_{rms} = \sqrt{\frac{3RT}{m}}$

$$v_0 = \sqrt{\frac{3R \times 200}{m}} \quad \dots(1)$$

$$v' = \sqrt{\frac{3R \times 800}{m}} \quad \dots(2)$$

dividing (2) by (1)

$$\frac{v'}{v_0} = \sqrt{\frac{800}{200}} = \sqrt{4} = 2$$

or  $v' = 2v_0$

32. Given below are two statements : one is labelled as assertion A and the other is labelled as Reason R

**Assertion A :** The phase difference of two light wave change if they travel through different media having same thickness, but different indices of refraction

**Reason R :** The wavelengths of waves are different in different media.

In the light of the above statements, choose the most appropriate answer from the options given below

- (1) Both A and R are correct and R is the correct explanation of A  
 (2) A is not correct but R is correct  
 (3) A is correct but R is not correct  
 (4) Both A and R are correct but R is NOT the correct explanation of A

Sol. (1)

Both the statements are true

As we know speed of light in a medium

$$v = \frac{c}{\mu} \text{ or } f\lambda = \frac{c}{\mu}$$

therefore  $\lambda \propto \frac{1}{\mu}$

when light will travel through two different mediums their phase difference will change

$$\Delta Q = \frac{2\pi}{\lambda} \Delta x$$

and R is correction explanation

33. For an amplitude modulated wave the minimum amplitude is 3 V, while the modulation index is 60%. The maximum amplitude of the modulated wave is :

- (1) 10 V                      (2) 12 V                      (3) 15 V                      (4) 5 V

Sol. (2)

Given, modulation index = 60% = 0.6

$$\frac{A_m}{A_c} = \frac{0.6}{1}$$

Using componendo – dividendo, we can write

$$\frac{A_m + A_c}{A_m - A_c} = \frac{0.6 + 1}{0.6 - 1} = \frac{1.6}{-0.4}$$

$$A_m + A_c = \frac{1.6}{-0.4} \times (A_m - A_c)$$

$$= \frac{1.6}{-0.4} \times (-3) = 12 \text{ V}$$

34. The ratio of speed of sound in hydrogen gas to the speed of sound in oxygen gas at the same temperature is :  
 (1) 1 : 4                      (2) 1 : 2                      (3) 1 : 1                      (4) 4 : 1

Sol. (4)

$$\text{Using } v = \sqrt{\frac{\gamma RT}{m}}$$

$$\frac{v_{H_2}}{v_{O_2}} = \sqrt{\frac{m_{O_2}}{m_{H_2}}} = \sqrt{\frac{32}{2}} = \sqrt{\frac{16}{1}} = 4 : 1$$

(since both hydrogen and oxygen are di-atomic,  $\gamma$  will be same)

35. A dipole comprises of two charged particles of identical magnitude  $q$  and opposite in nature. The mass ' $m$ ' of the positive charged particle is half of the mass of the negative charged particle. The two charges are separated by a distance ' $l$ '. If the dipole is placed in a uniform electric field ' $E$ '; in such a way that dipole axis makes a very small angle with the electric field, ' $E$ '. The angular frequency of the oscillations of the dipole when released is given by :

- (1)  $\sqrt{\frac{4qE}{3ml}}$                       (2)  $\sqrt{\frac{8qE}{ml}}$                       (3)  $\sqrt{\frac{8qE}{3ml}}$                       (4)  $\sqrt{\frac{4qE}{ml}}$

Sol. (1)

In this case, since masses of both charges are not same, therefore, we need to find center of mass (COM), about which dipole will oscillate and then we will find moment of Inertia about this axis, to find torque & hence  $\omega$ . As we know, COM will divide length in the inverse ratio of the masses, therefore, COM will be at a distance of

$$\frac{L}{3} \text{ from } 2m \text{ \& } \frac{2L}{3} \text{ from } m.$$

MI about this axis

$$I = 2m\left(\frac{L}{3}\right)^2 + \left(\frac{2L}{3}\right)^2$$

$$\text{Or } I = \frac{2mL^2}{9} + \frac{4mL^2}{9} = \frac{6mL^2}{9} = \frac{2mL^2}{3}$$

$$\text{Using } \omega = \frac{2mL^2}{3} \text{ \& } p = qL$$

$$\omega = \sqrt{\frac{qLE}{\frac{2L^2}{3}}} = \sqrt{\frac{3qE}{2mL}}$$

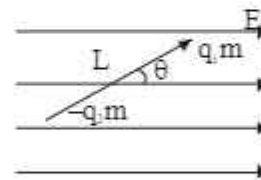

None of these given option is correct. (BONUS)

36. Given below are two statements: one is labelled as Assertion A and the other is labelled as Reason R  
**Assertion A** : When you squeeze one end of a tube to get toothpaste out from the other end. Pascal's principle is observed.

**Reason R** : A change in the pressure applied to an enclosed incompressible fluid is transmitted undiminished to every portion of the fluid and to the walls of its container.

In the light of the above statements, choose the most appropriate answer from the options given below

- (1) A is correct but R is not correct  
 (2) Both A and R are correct and R is the correct explanation of A  
 (3) A is not correct but R is correct  
 (4) Both A and R are correct but R is NOT the correct explanation of A

Sol. (2)

As per pascal's law, when we apply pressure to an ideal liquid it is equally distributed in the entire liquid and to the walls as well.

Since due to applied pressure, every morning, the tooth paste does not get compressed and we can safely consider it on incompressible liquid.

Therefore both statements are true and R is correct explanation of A.

37. A student is provided with a variable voltage source  $V$ , a test resistor  $R_T = 10\Omega$ , two identical galvanometers  $G_1$  and  $G_2$  and two additional resistors,  $R_1 = 10M\Omega$  and  $R_2 = 0.001\Omega$ . For conducting an experiment to verify ohm's law, the most suitable circuit is :

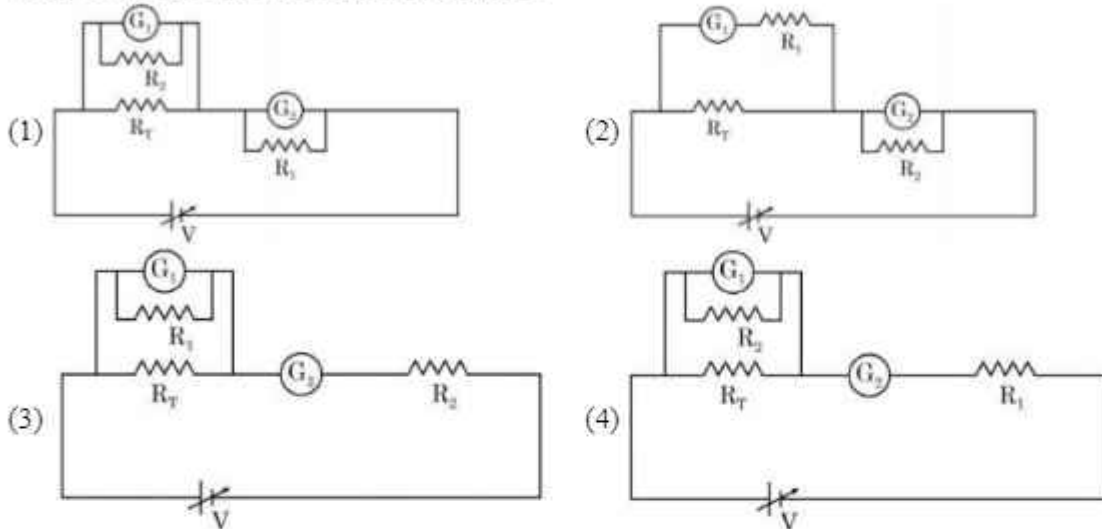

- Sol. (2)  
 This question is based on the conceptual clarity that we should connect ammeter in series and voltmeter in parallel to measure current and potential difference, respectively  
 Also, when we use a galvanometer to create an ammeter, shunt resistance should be very small and should be in parallel.  
 When we create a voltmeter shunt should be large and in series with galvanometer.  
 All these criteria are satisfied in option (2)

38. A body cools in 7 minutes from  $60^\circ\text{C}$  to  $40^\circ\text{C}$ . The temperature of the surrounding is  $10^\circ\text{C}$ . The temperature of the body after the next 7 minutes  
 (1)  $30^\circ\text{C}$  (2)  $34^\circ\text{C}$  (3)  $32^\circ\text{C}$  (4)  $28^\circ\text{C}$

- Sol. (4)  
**Method-1**  
 Using exact law of cooling  
 $T - T_s = (T_0 - T_s) e^{-kt}$   
 Case-I:  $(40 - 10) = (60 - 10) e^{-7k}$   
 $30 = 50e^{-7k}$  .....(1)  
 Case-II:  $(T - 10) = (40 - 10) e^{-7k}$  or  $T - 10 = 30 e^{-7k}$   
 Dividing (2) by (1)

$$\frac{T - 10}{30} = \frac{30}{50}$$

$$\Rightarrow T - 10 = \frac{30 \times 30}{50} = 18$$

or  $T = 28^\circ\text{C}$

**Method-2**

Using newton's average law of cooling

$$\frac{T_1 - T_2}{t} = k \left( \frac{T_1 + T_2}{2} - T_s \right)$$

Case-I:-  $\frac{60 - 40}{7} = k \left[ \frac{60 + 40}{2} - 10 \right] \Rightarrow \frac{20}{7} = k [40]$  .....(i)

Case-II:-  $\frac{40 - T}{7} = k \left[ \frac{40 + T}{2} - 10 \right]$  .....(2)

Dividing (2) by (1)

$$\frac{40 - T}{20} = \frac{20 + T}{80}$$

$$160 - 4T = 20 + T$$

$$5T = 140$$

$$T = 28 \text{ } ^\circ\text{C}$$

39. The energy density associated with electric field  $\vec{E}$  and magnetic field  $\vec{B}$  of an electromagnetic wave in free space is given by ( $\epsilon_0$  - permittivity of free space,  $\mu_0$  - permeability of free space)

$$(1) U_E = \frac{\epsilon_0 E^2}{2}, U_B = \frac{B^2}{2\mu_0}$$

$$(2) U_E = \frac{E^2}{2\epsilon_0}, U_B = \frac{\mu_0 B^2}{2}$$

$$(3) U_E = \frac{E^2}{2\epsilon_0}, U_B = \frac{B^2}{2\mu_0}$$

$$(4) U_E = \frac{\epsilon_0 E^2}{2}, U_B = \frac{\mu_0 B^2}{2}$$

Sol. (1)

By theory of electromagnetic waves

$$U_E = \frac{1}{2} \epsilon_0 E^2 \text{ and}$$

$$U_B = \frac{1}{2} \frac{B^2}{\mu_0}$$

40. The weight of a body on the surface of the earth is 100 N. The gravitational force on it when taken at a height, from the surface of earth, equal to one-fourth the radius of the earth is :

(1) 64 N

(2) 25 N

(3) 100 N

(4) 50 N

Sol. (1)

using newton's formula  $F = \frac{GMm}{r^2}$

at surface of earth,  $100 = \frac{GM_e m}{R_e^2}$  ....(1)

at  $r = R_e + \frac{R_e}{4} = \frac{5}{4} R_e$

$$F' = \frac{GM_e m}{\left(\frac{5}{4} R_e\right)^2} = \frac{16}{25} \times \frac{GM_e m}{R_e^2}$$

$$F' = \frac{16}{25} \times 100 = 64 \text{ N}$$

41. A capacitor of capacitance  $150.0 \text{ } \mu\text{F}$  is connected to an alternating source of emf given by  $E = 36 \sin(120\pi t) \text{ V}$ . The maximum value of current in the circuit is approximatively equal to :

(1)  $\sqrt{2} \text{ A}$

(2)  $2\sqrt{2} \text{ A}$

(3)  $\frac{1}{\sqrt{2}} \text{ A}$

(4) 2A

Sol. (4)

Given alternating AC source  $E = 36 \sin(120\pi t) \text{ v}$  & capacitor  $C = 150 \text{ } \mu\text{F}$

using  $Q = CV$

we can write  $Q = (CE_0 \sin \omega t)$

$$\text{Current } i = \frac{dQ}{dt} = (CE_0 \omega \cos \omega t)$$

max. value of current  $i_0 = CE_0 \omega$

$$\text{or } i_0 = 150 \times 10^{-6} \times 36 \times 120\pi = 2.03 \text{ A}$$

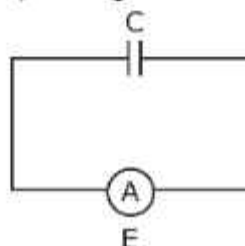

42. A 2 meter long scale with least count of 0.2 cm is used to measure the locations of objects on an optical bench. While measuring the focal length of a convex lens, the object pin and the convex lens are placed at 80 cm mark and 1 m mark, respectively. The image of the object pin on the other side of lens coincides with image pin that is kept at 180 cm mark. The % error in the estimation of focal length is :

(1) 0.51                      (2) 1.02                      (3) 0.85                      (4) 1.70

Sol. (4)

Based on the data provided

$$U = 100 - 80 = 20 \text{ cm}$$

$$V = 180 - 100 = 80 \text{ cm}$$

$$\text{Using } \frac{1}{f} = \frac{1}{v} + \frac{1}{u} \text{ or } f = \frac{uv}{u+v} = \frac{20 \times 80}{20+80} \text{ or } f = 16 \text{ cm}$$

For error analysis,

$$\frac{1}{f} = \frac{1}{v} + \frac{1}{u}$$

Differentiating

$$-\frac{Df}{f^2} = -\frac{Dv}{v^2} - \frac{\Delta u}{u^2}$$

To calculate  $\Delta u$  &  $\Delta v$

$$U = (100 \pm 2) - (80 \pm 0.2) = (20 \pm 0.4) \text{ cm}$$

Therefore  $\Delta u = 0.4 \text{ cm}$ ,

Similarly  $\Delta v = 0.4 \text{ cm}$ .

$$\text{Now } \frac{\Delta f}{f} = f \left[ \frac{\Delta v}{v^2} + \frac{\Delta u}{u^2} \right]$$

$$\frac{\Delta f}{f} = 16 \left[ \frac{0.4}{(80)^2} + \frac{0.4}{(20)^2} \right]$$

(Note: every data is in cm)

$$\frac{\Delta f}{f} = \frac{16 \times 0.4}{(20)^2} \left[ \frac{1}{4^2} + 1 \right]$$

$$= \frac{16 \times 0.4}{20^2} \times \frac{17}{16} = \frac{17 \times 0.4}{400}$$

$$\% \text{ Error} : \frac{\Delta f}{f} \times 100 = \frac{17 \times 0.4}{400} \times 1000$$

$$= 1.7$$

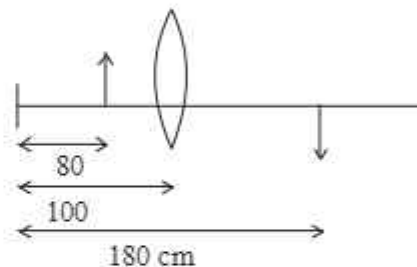

43. Figure shows a part of an electric circuit. The potentials at points a, b and c are 30 V, 12 V and 2 V respectively. The current through the 20  $\Omega$  resistor will be

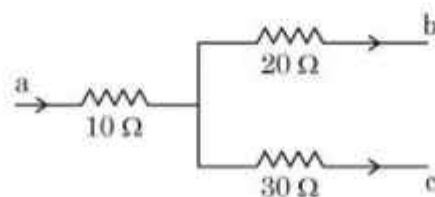

(1) 1.0 A                      (2) 0.2 A                      (3) 0.4 A                      (4) 0.6 A

Sol. (3)

Let potential of the junction be x volts

using junction law  $i_1 + i_2 + i_3 = 0$

$$\text{or } \frac{x-30}{10} + \frac{x-12}{20} + \frac{x-2}{30} = 0$$



**Sol. (1)**  
 Given,  $m = 5\text{ kg}$ ,  $R = 2\text{ m}$   
 time  $t$  for 1 rev = 3.14 sec or  $\pi$  sec  
 $\theta$  for 1 rev =  $2\pi$  rad  
 Therefore  $\omega = \frac{\theta}{t} = \frac{2\pi}{\pi} = 2\text{ rad/s}$   
 centrifugal force  $F = mR\omega^2$   
 or  $F = 5 \times 2 \times 2^2 = 40\text{ N}$

48. As shown in the figure, a particle is moving with constant speed  $\pi\text{ m/s}$ . Considering its motion from A to B, the magnitude of the average velocity is :

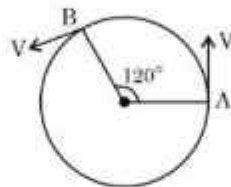

- (1)  $\pi\text{ m/s}$                       (2)  $2\sqrt{3}\text{ m/s}$                       (3)  $\sqrt{3}\text{ m/s}$                       (4)  $1.5\sqrt{3}\text{ m/s}$

**Sol. (4)**  
 Given speed  $v = \pi\text{ m/s}$   
 or  $R\omega = \pi$   
 or  $\omega = \frac{\pi}{R}\text{ rad/s}$   
 angular displacement  $\theta = 120^\circ$  or  $\frac{2\pi}{3}$   
 using  $\theta = \omega t$   
 $t = \frac{\theta}{\omega} = \frac{2\pi/3}{\pi/R} = \frac{2R}{3}$   
 linear displacement  $d = 2R \sin(\theta/2)$   
 $d = 2R \sin\left(\frac{120}{2}\right)$   
 $= 2R \times \sin 60 = 2R \times \frac{\sqrt{3}}{2}$   
 $= R\sqrt{3}$   
 average velocity =  $\frac{d}{t} = \frac{R\sqrt{3}}{2R/3} = \frac{3\sqrt{3}}{2}$

49. The work functions of Aluminium and Gold are 4.1 eV and 5.1 eV respectively. The ratio of the slope of the stopping potential versus frequency plot for Gold to that of Aluminium is

- (1) 1                      (2) 2                      (3) 1.24                      (4) 1.5

**Sol. (1)**  
 Using  $KE_{\max} = eV_s = hf - \phi_0$   
 where  $\phi_0$  is work function,  $V_s$  is stopping potential and  $f$  is frequency  
 or  $V_s = \frac{h}{e}f - \frac{\phi_0}{e}$   
 therefore the slope  $m$  will be same for all graphs and will be independent of  $\phi_0$ .

50. A particle starts with an initial velocity of  $10.0 \text{ ms}^{-1}$  along x-direction and accelerates uniformly at the rate of  $2.0 \text{ ms}^{-2}$ . The time taken by the particle to reach the velocity of  $60.0 \text{ ms}^{-1}$  is \_\_\_\_\_.
- (1) 3s                      (2) 6s                      (3) 25s                      (4) 30s

Sol. (3)

Using 1<sup>st</sup> equation of motion

$$t = \frac{v - u}{a}$$

$$t = \frac{60 - 10}{2} = \frac{50}{2} = 25 \text{ sec}$$

### SECTION - B

51. A simple pendulum with length 100 cm and bob of mass 250 g is executing S.H.M. of amplitude 10 cm. The maximum tension in the string is found to be  $\frac{x}{40} \text{ N}$ . The value of x is \_\_\_\_\_.

Sol. (99)

For pendulum

$$T_{\max} = mg + \frac{mv^2}{L} \quad \dots(1)$$

Given  $m = \frac{1}{4} \text{ kg}$ ,  $L = 1 \text{ m}$ ,  $g = 9.8 \text{ m/s}^2$

and amplitude  $A = \frac{1}{10} \text{ m}$

For SHM,  $KE_{\max} = \frac{1}{2} mv^2 = \frac{1}{2} m\omega^2 A^2$

using  $\omega = \sqrt{\frac{g}{L}}$

$$mv^2 = m \left( \sqrt{\frac{g}{L}} \right)^2 A^2 = \frac{mgA^2}{L} \quad \dots(2)$$

using (2) in (1)

$$T_{\max} = 2mg + \frac{mgA^2}{L}$$

$$= mg \left[ 1 + \frac{1}{10^2} \right] = \frac{1}{4} \times 9.8 \times \frac{101}{100}$$

$$\text{or } T_{\max} = \frac{98.98}{40}$$

Therefore  $x = 99$

52. Experimentally it is found that 12.8 eV energy is required to separate a hydrogen atom into a proton and an electron. So the orbital radius of the electron in a hydrogen atom is  $\frac{9}{x} \times 10^{-10} \text{ m}$ . The value of the x is : \_\_\_\_\_.

(1 eV =  $1.6 \times 10^{-19} \text{ J}$ ,  $\frac{1}{4\pi\epsilon_0} = 9 \times 10^9 \text{ Nm}^2 / \text{C}^2$  and electronic charge =  $1.6 \times 10^{-19} \text{ C}$ )



Sol. (16)

$$\text{Using } E = \frac{ke^2}{2r}$$

$$r = \frac{Re^2}{2E}$$

Given  $E = 12.8 \text{ eV} = 12.8 \times e \text{ Joule}$

$$r = \frac{9 \times 10^9 e^2}{2 \times 12.8 e} = \frac{9 \times 10^9 \times 1.6 \times 10^{-19}}{2 \times 12.8}$$

$$r = \frac{9 \times 10^{-10}}{(2 \times 12.8 / 1.6)} = \frac{9 \times 10^{-10}}{10} \text{ m}$$

Therefore  $x = 16$

53. A beam of light consisting of two wavelengths  $7000 \text{ \AA}$  and  $5500 \text{ \AA}$  is used to obtain interference pattern in Young's double slit experiment. The distance between the slits is  $2.5 \text{ mm}$  and the distance between the place of slits and the screen is  $150 \text{ cm}$ . The least distance from the central fringe, where the bright fringes due to both the wavelengths coincide, is  $n \times 10^{-5} \text{ m}$ . The value of  $n$  is \_\_\_\_\_.

Sol. (462)

Let  $n_1$  maxima of  $7000 \text{ \AA}$  coincides with  $n_2$  maxima of  $5500 \text{ \AA}$

therefore  $n_1 \beta_1 = n_2 \beta_2$

$$\text{or } \frac{n_1}{n_2} = \frac{\lambda_2}{\lambda_1} = \frac{5500}{7000} = \frac{11}{14}$$

therefore  $11^{\text{th}}$  maxima of  $7000 \text{ \AA}$  will coincide with  $14^{\text{th}}$  maximum of  $5500 \text{ \AA}$

To find the least distance of this

$$y = n_1 \beta_1$$

$$\text{or } y = \frac{n_1 \lambda_1 D}{d} = \frac{11 \times 7000 \times 10^{-10} \times 150 \times 10^{-2}}{2.5 \times 10^{-3}}$$

$$= \frac{11 \times 7 \times 5}{2.5} \times 10^{-5} \text{ m}$$

$$\text{or } y = 462 \times 10^{-5} \text{ m}$$

therefore  $n = 462$

54. Two concentric circular coils with radii  $1 \text{ cm}$  and  $1000 \text{ cm}$ , and number of turns  $10$  and  $200$  respectively are placed coaxially with centers coinciding. The mutual inductance of this arrangement will be \_\_\_\_\_  $\times 10^{-8} \text{ H}$ . (Take,  $\pi^2 = 10$ )

Sol. (4)

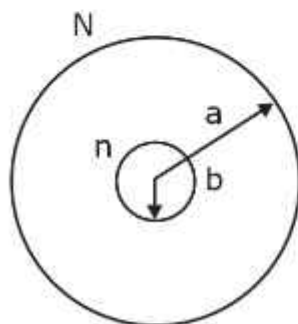

Given

$$a = 1000 \text{ cm}$$

$$b = 1 \text{ cm}$$

$$\text{or } b \ll a$$

we will take larger coil as primary

$$B = \frac{\mu_0 i_p N}{2a}$$

$$\text{flux } \phi_s = BA = \frac{\mu_0 i_p N}{2a} \times \pi b^2 \times n$$

$$\text{Mutual inductance } M = \frac{\phi_s}{i_p}$$

$$M = \frac{\mu_0 N n \pi b^2}{2 \times a}$$

$$\text{or } M = \frac{4\pi \times 10^{-7} \times 200 \times 10 \times \pi \times 1 \times 10^{-2}}{2 \times 1000 \times 10^{-2}}$$

$$= 4\pi^2 \times 10^{-9}$$

$$\text{or } M = 4 \times 10^{-9} \text{ (using } \pi^2 = 10)$$

55. As shown in the figure, two parallel plate capacitors having equal plate area of  $200 \text{ cm}^2$  are joined in such a way that  $a \neq b$ . The equivalent capacitance of the combination is  $x \epsilon_0 \text{ F}$ . The value of  $x$  is \_\_\_\_\_.

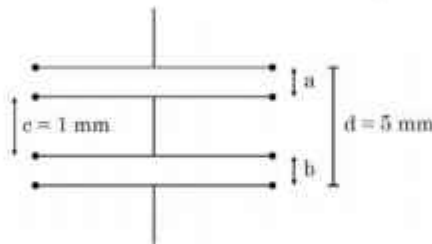

Sol. (5)

As per the arrangement given, distance between the capacitor plates are  $a$  and  $b$  and  $a \neq b$  using the diagram we can write

$$b = 5 - a - 1 = (4 - a) \text{ in mm}$$

$$\text{as we know capacitance of capacitor } C = \frac{\epsilon_0 A}{d}$$

and in series arrangement

$$\frac{1}{C_{eq}} = \frac{1}{C_1} + \frac{1}{C_2}$$

$$\frac{1}{C_{eq}} = \frac{a}{\epsilon_0 A} + \frac{4-a}{\epsilon_0 A} = \frac{4(\text{in mm})}{\epsilon_0 A}$$

$$\text{or } C_{eq} = \frac{\epsilon_0 A}{4(\text{mm})}$$

$$\text{Given } A = 200 \text{ cm}^2$$

$$C_{eq} = \frac{\epsilon_0 \times 200 \times 10^{-4}}{4 \times 10^{-1}}$$

$$= \epsilon_0 50 \times 10^{-1}$$

$$\text{or } C_{eq} = 5\epsilon_0 \text{ farad}$$

therefore  $n = 5$

56. A proton with a kinetic energy of  $2.0 \text{ eV}$  moves into a region of uniform magnetic field of magnitude  $\frac{\pi}{2} \times 10^{-3} \text{ T}$ .

The angle between the direction of magnetic field and velocity of proton is  $60^\circ$ . The pitch of the helical path taken by the proton is \_\_\_\_\_ cm.

(Take, mass of proton =  $1.6 \times 10^{-27} \text{ kg}$  and Charge on proton =  $1.6 \times 10^{-19} \text{ C}$ ).

Sol. (40)

$$B = \frac{\pi}{2} \times 10^{-3}$$

$$\text{K.E.} = \frac{1}{2} mV^2$$

$$\Rightarrow V = \sqrt{\frac{2\text{KE}}{m}}$$

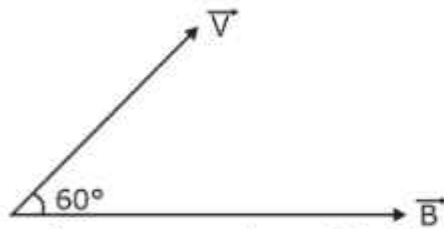

Pitch =  $v \cos 60^\circ \times$  time period of one rotation

$$= v \cos 60^\circ \times \frac{2\pi m}{eB}$$

$$= \sqrt{\frac{2 \times 2 \times 1.6 \times 10^{-9}}{1.6 \times 10^{-27}}} \times \cos 60^\circ \times \frac{2\pi \times 1.6 \times 10^{-27}}{1.6 \times 10^{-19} \times \frac{\pi}{2} \times 10^{-3}}$$

$$= 2 \times 10^4 \times \frac{1}{2} \times 4 \times 10^{-5}$$

$$= 4 \times 10^{-1} \text{ m} = 40 \text{ cm}$$

57. A body is dropped on ground from a height ' $h_1$ ' and after hitting the ground, it rebounds to a height ' $h_2$ '. If the ratio of velocities of the body just before and after hitting ground is 4, then percentage loss in kinetic energy of the body is  $\frac{x}{4}$ . The value of x is \_\_\_\_\_.

Sol. (375)

Let u and v be speeds, just before and after body strikes the ground.

$$\text{Given } \frac{u}{v} = \frac{4}{1}$$

$$\text{loss in KE: } \Delta\text{KE} = \frac{\frac{1}{2} mu^2 - \frac{1}{2} mv^2}{\frac{1}{2} mu^2}$$

$$\Delta\text{KE} = 1 - \left(\frac{v}{u}\right)^2 = 1 - \frac{1}{16} = \frac{15}{16}$$

$$\text{Percentage loss} = \frac{15}{16} \times 100 = 375$$

58. A ring and a solid sphere rotating about an axis passing through their centers have same radii of gyration. The axis of rotation is perpendicular to plane of ring. The ratio of radius of ring to that of sphere is  $\sqrt{\frac{2}{x}}$ . The value of x is \_\_\_\_\_.

Sol. (5)  
 Given radius of gyration is same for ring and solid sphere  
 $K_R = K_{ss}$

$$R_R = \sqrt{\frac{2}{5}} R_{ss}$$

$$\text{or } \frac{R_R}{R_{ss}} = \sqrt{\frac{2}{5}}$$

therefore  $x = 5$

59. As shown in the figure, the voltmeter reads 2 V across  $5 \Omega$  resistor. The resistance of the voltmeter is  $\_\_\_\Omega$ .

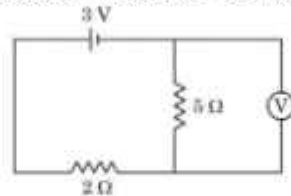

Sol. (20)  
**Method-I:**

$$R_{eq} = 2 + \frac{5R}{5+R} = \frac{10+7R}{5+R}$$

$$i = \frac{3}{R_{eq}} = \frac{3(5+R)}{10+7R}$$

$$i_1 = \frac{2}{5}, i_2 = \frac{2}{R}$$

$$i = i_1 + i_2$$

$$\frac{3(5+R)}{10+7R} = \frac{2}{5} + \frac{2}{R} = \frac{2(5+R)}{5R}$$

$$15R(5+R) = 2(5+R)(10+7R)$$

$$75R + 15R^2 = 2(50 + 35R + 10R + 7R^2)$$

$$15R^2 + 75R = 14R^2 + 90R + 100$$

$$R^2 - 15R - 100 = 0$$

$$R = \frac{15 \pm \sqrt{225 + 4 \times 100}}{2}$$

$$= \frac{15 \pm \sqrt{625}}{2} = \frac{15 \pm 25}{2}$$

$$R = 20 \Omega$$

**Method-II:**

Given potential across  $5\Omega$  and voltmeter is 2V. To find resistance R of voltmeter.

Let current in  $5\Omega$  be  $i_1$ , and in R  $i_2$ .

$$i_1 = \frac{2}{5} \text{ and } i_2 = \frac{2}{R}$$

V across  $2\Omega$  will be 1 volt and  $i = \frac{1}{2} \text{ A}$ .

Using junction law:  $i = i_1 + i_2$

$$\frac{1}{2} = \frac{2}{5} + \frac{2}{R}$$

$$\frac{2}{R} = \frac{1}{2} - \frac{2}{5} = \frac{1}{10}$$

$$R = 20\Omega$$

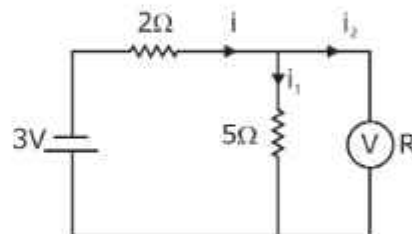

60. A metal block of mass  $m$  is suspended from a rigid support through a metal wire of diameter 14 mm. The tensile stress developed in the wire under equilibrium state is  $7 \times 10^5 \text{ Nm}^{-2}$ . The value of mass  $m$  is \_\_\_\_\_ kg.

(Take,  $g = 9.8 \text{ ms}^{-2}$  and  $\pi = \frac{22}{7}$ )

Sol. 11

$$\text{Using stress} = \frac{\text{force}}{\text{area}} = \frac{mg}{A}$$

$$\Rightarrow m = \frac{S \times A}{g} = \frac{7 \times 10^5 \times \pi R^2}{g}$$

$$= \frac{7 \times 10^5 \times \frac{22}{7} \times (7 \times 10^{-3})^2}{9.8} \quad (\text{Note: 14 mm is diameter})$$

$$= 11 \text{ kg}$$

## SECTION - A

61. Match List I with List II

List I (Natural Amino acid)	List II (One Letter Code)
(A) Arginine	(I) D
(B) Aspartic acid	(II) N
(C) Asparagine	(III) A
(D) Alanine	(IV) R

Choose the correct answer from the options given below:

- (1) (A) – III, (B) – I, (C) – II (D) – IV      (2) (A) – IV, (B) – I, (C) – II (D) – III  
 (3) (A) – IV, (B) – I, (C) – III (D) – II      (4) (A) – I, (B) – III, (C) – IV (D) – II

Sol. 2

Natural Amino acid	One Letter Code
(i) Arginine	R
(ii) Aspartic acid	D
(iii) Asparagine	N
(iv) Alanine	A

62. Formation of which complex, among the following, is not a confirmatory test of  $Pb^{2+}$  ions

- (1) lead sulphate      (2) lead nitrate      (3) lead chromate      (4) lead iodide

Sol. 2

∴  $Pb(NO_3)_2$  is a soluble colourless compound so it cannot be used in confirmatory test of  $Pb^{2+}$  ion.

Topic : Redox Reaction

Sub Topic : Titration

Level : Easy

63. The volume of 0.02 M aqueous HBr required to neutralize 10.0 mL of 0.01 M aqueous  $Ba(OH)_2$  is (Assume complete neutralization)

- (1) 5.0 mL      (2) 10.0 mL      (3) 2.5 mL      (4) 7.5 mL

Sol. 2

$$\begin{aligned} \text{m.eq. of HBr} &= \text{m.eq. of Ba(OH)}_2 \\ M_1 \times n_1 \times V_1(\text{mL}) &= M_2 \times n_2 \times V_2(\text{mL}) \\ 0.02 \times 1 \times V_1(\text{mL}) &= 0.02 \times 2 \times 10 \\ V_1(\text{mL}) &= 10 \text{ mL} \end{aligned}$$

64. Group-13 elements react with  $O_2$  in amorphous form to form oxides of type  $M_2O_3$  (M = element). Which among the following is the most basic oxide?

- (1)  $Al_2O_3$       (2)  $Tl_2O_3$       (3)  $Ga_2O_3$       (4)  $B_2O_3$

Sol. 2

As electropositive character increases basic character of oxide increases.

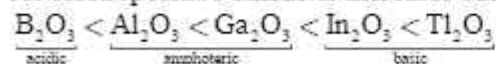

65. The IUPAC name of  $K_3[Co(C_2O_4)_3]$  is -

- (1) Potassium tris(oxalate) cobaltate(III)      (2) Potassium trioxalatocobalt(III)  
 (3) Potassium trioxalatocobaltate(III)      (4) Potassium tris(oxalate)cobalt(III)

Sol. 3

IUPAC name of  $K_3[Co(C_2O_4)_3]$  is Potassium trioxalatocobaltate(III)

**Topic : Atomic Structure**  
**Sub Topic : De-Broglie Principle**  
**Level : Moderate**

66. If the radius of the first orbit of hydrogen atom is  $a_0$ , then de Broglie's wavelength of electron in 3<sup>rd</sup> orbit is  
 (1)  $\frac{\pi a_0}{6}$                       (2)  $\frac{\pi a_0}{3}$                       (3)  $6\pi a_0$                       (4)  $3\pi a_0$

**Sol. 3**  
 By De-Broglie principle

$$2\pi r = n\lambda$$

$$2\pi \times \frac{n^2}{z} a_0 = n\lambda$$

$$2\pi \times \frac{n}{z} a_0 = \lambda$$

$$\lambda = 2\pi \times \frac{3}{1} a_0 = 6\pi a_0$$

**Topic : Chemistry in everyday life**  
**Sub Topic : Pesticides**  
**Level : Easy**

67. The group of chemicals used as pesticide is  
 (1) Sodium chlorate, DDT, PAN                      (2) DDT, Aldrin  
 (3) Aldrin, Sodium chlorate, Sodium arsinite                      (4) Dieldrin, Sodium arsinite, Tetrachlorothene

**Sol. 2**  
 (Fact base)  
 DDT & Aldrin are used as pesticide

**Topic : Surface Chemistry**  
**Sub Topic : Chromatography**  
**Level : Moderate**

68. From the figure of column, chromatography given below, identify incorrect statements.

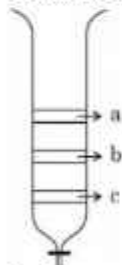

- A. Compound 'c' is more polar than 'a' and 'b'  
 B. Compound 'a' is least polar  
 C. Compound 'b' comes out of the column before 'c' and after 'a'  
 D. Compound 'a' spends more time in the column

Choose the correct answer from the options given below:

- (1) A, B and D only      (2) A, B and C only      (3) B and D only      (D) B, C and D only

**Sol. 2**

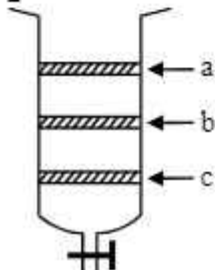

- (i) Since C is eluting first and a is last that means C is least polar and a is most polar.  
(ii) So incorrect options will be (A), (B), (C)

Adsorption of compound  $\propto$  Attraction

$\propto$  Polarity

$\propto$  Spend time in column

$\propto \frac{1}{\text{come out from column}}$

Order of polarity  $\rightarrow a > b > c$

Come out from column order  $\rightarrow c > b > a$

Spend time in column  $\rightarrow a > b > c$

69. Ion having highest hydration enthalpy among the given alkaline earth metal ions is:

- (1)  $\text{Be}^{2+}$                       (2)  $\text{Ba}^{2+}$                       (3)  $\text{Ca}^{2+}$                       (4)  $\text{Sr}^{2+}$

Sol. 1

Hydration enthalpy  $\propto \frac{1}{\text{size}}$

Down the group as size increases hydration enthalpy decreases

Order:  $\text{Be}^{2+} > \text{Mg}^{2+} > \text{Ca}^{2+} > \text{Sr}^{2+} > \text{Ba}^{2+}$

Topic : Alcohol

Sub Topic : Acidic Strength

Level : Easy

70. The strongest acid from the following is

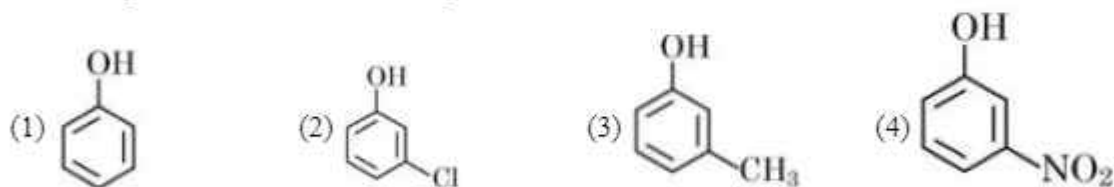

Sol. 4

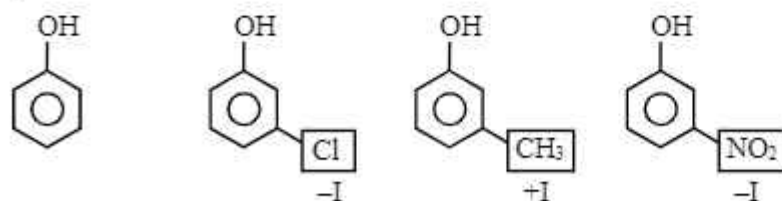

Since  $-I$  of  $-\text{NO}_2 > \text{Cl}$

So, most acidic will be (4)



Topic : Hydrogen  
 Sub Topic : Alkene-Chemical Properties  
 Level : Moderate

71. In the following reaction, 'B' is

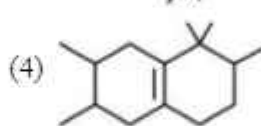
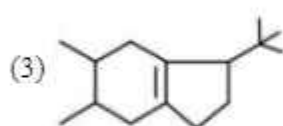
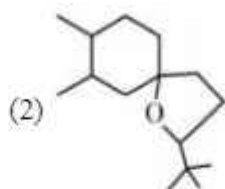
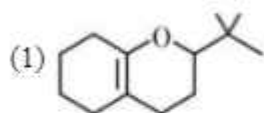
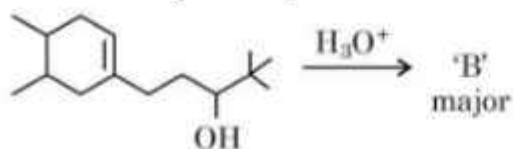

Sol. 4

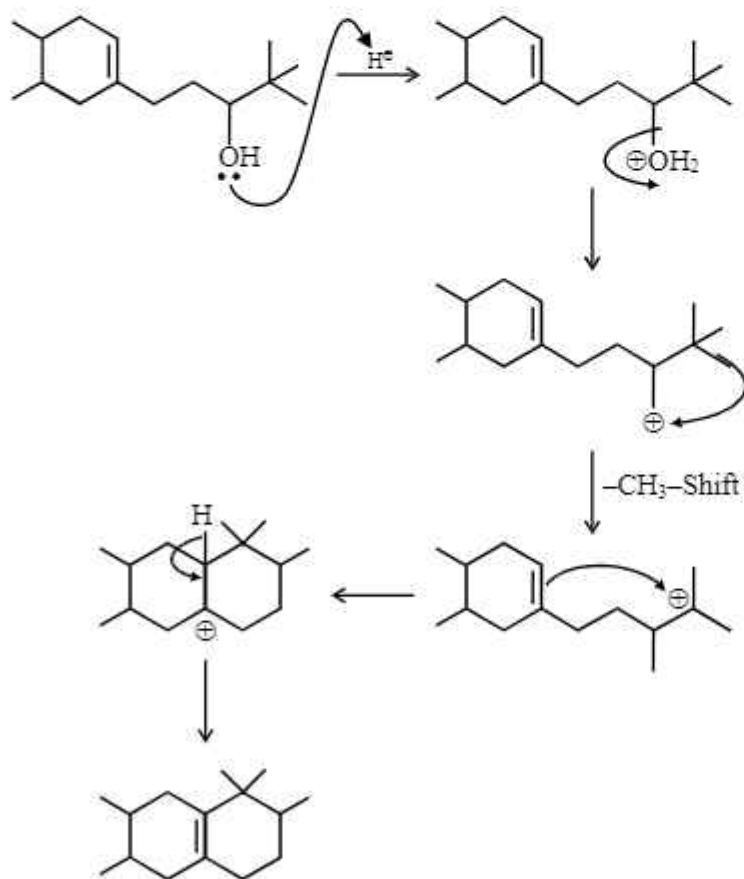

72. Structures of  $BeCl_2$  in solid state, vapour phase and at very high temperature respectively are:

- (1) Polymeric, Dimeric, Monomeric      (2) Dimeric, Polymeric, Monomeric  
 (3) Monomeric, Dimeric, Polymeric      (4) Polymeric, Monomeric, Dimeric

Sol. 1

In solid state  $BeCl_2$  as polymer, in vapour state it form chloro-bridged dimer while above 1200K it is monomer.

**Topic** : Chemical Kinetic  
**Sub Topic** : Complex Reaction/Activation energy  
**Level** : Moderate

73. Consider the following reaction that goes from A to B in three steps as shown below:

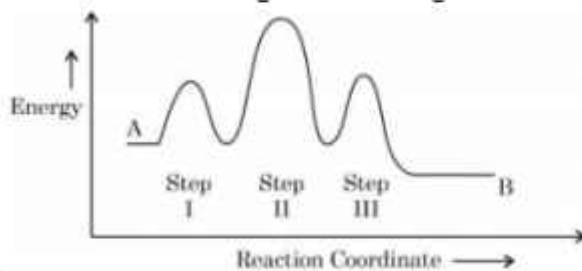

Choose the correct option

	Number of intermediates	Number of Activated complex	Rate determining step
(1)	2	3	II
(2)	3	2	II
(3)	2	3	III
(4)	2	3	I

**Sol.** 1

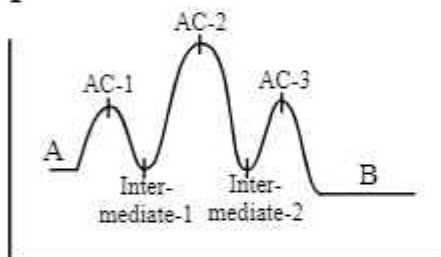

Number of Intermediate  $\rightarrow$  2  
 Number of Activated complex  $\rightarrow$  3  
 Rate determining step  $\rightarrow$  II

**Topic** : Electrochemistry  
**Sub Topic** : Electrolyte Cell  
**Level** : Easy

74. The product, which is not obtained during the electrolysis of brine solution is  
 (1) HCl (2) NaOH (3) Cl<sub>2</sub> (4) H<sub>2</sub>

**Sol.** 1

Brine solution (NaCl + H<sub>2</sub>O)

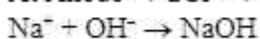
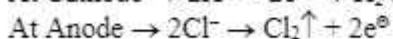
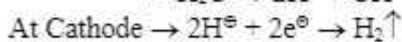
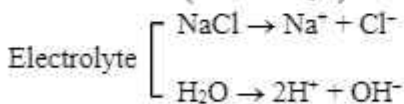

Answer 1 (HCl)

75. Which one of the following elements will remain as liquid inside pure boiling water?  
 (1) Li (2) Ga (3) Cs (4) Br

**Sol.** 2

Li, Cs reacts vigorously with water.

Br<sub>2</sub> changes in vapour state in boiling water (BP = 58°C)

Ga reacts with water above 100°C (MP = 29°C, BP = 2400°C)

76. Given below are two statements: one is labelled as "Assertion A" and the other is labelled as "Reason R"
- Assertion A:** In the complex  $\text{Ni}(\text{CO})_4$  and  $\text{Fe}(\text{CO})_5$ , the metals have zero oxidation state.
- Reason R:** Low oxidation states are found when a complex has ligands capable of  $\pi$ -donor character in addition to the  $\sigma$ -bonding.
- In the light of the above statement, choose the most appropriate answer from the options given below
- (1) A is not correct but R is correct.
  - (2) A is correct but R is not correct
  - (3) Both A and R are correct and R is the correct explanation of A
  - (4) Both A and R are correct but R is NOT the correct explanation of A.

Sol. 2

Low oxidation state of metals can be stabilized by synergic bonding so ligand has to be  $\pi$ -acceptor.

Topic : Chemistry in everyday life

Sub Topic : Chemical in medicines

Level : Easy

77. Given below are two statements:
- Statement I:** Morphine is a narcotic analgesic. It helps in relieving pain without producing sleep.
- Statement II:** Morphine and its derivatives are obtained from opium poppy.
- In the light of the above statements, choose the correct answer from the options given below
- (1) Statement I is true but statement II is false
  - (2) Both statement I and statement II are true
  - (3) Statement I is false but statement II is true
  - (4) Both Statement I and Statement II are false

Sol. 2

Fact

Morphine  $\rightarrow$

- (i) Morphine is a narcotic analgesic, it helps in relieving pain and producing sleep.
- (ii) Morphine and its derivatives are obtained from opium.

78. Find out the major product from the following reaction.

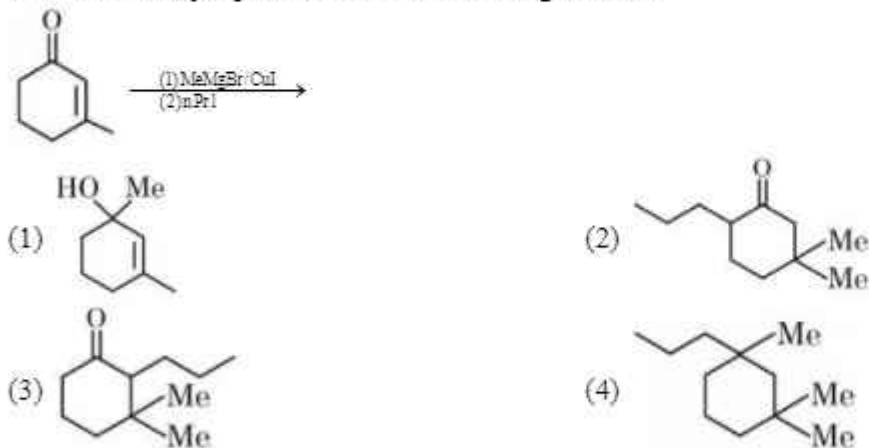

Sol. 3

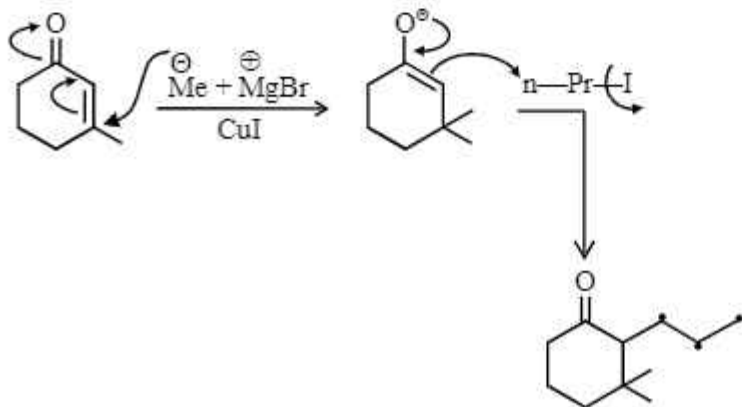

79. During the reaction of permanganate with thiosulphate, the change in oxidation of manganese occurs by value of 3. Identify which of the below medium will favour the reaction

- (1) aqueous neutral (2) aqueous acidic  
(3) both aqueous acidic and neutral (4) both aqueous acidic and faintly alkaline

Sol. 1

In neutral or weakly alkaline solution oxidation state of Mn changes by 3 unit

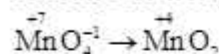

80. Element not present in Nessler's reagent is

- (1) K (2) N (3) I (4) Hg

Sol. 2

Nessler reagent is-  $\text{K}_2[\text{HgI}_4]$

## SECTION - B

Topic : Electrochemistry

Sub Topic : Reactivity Series of Metal

Level : Moderate

81. The standard reduction potentials at 298 K for the following half cells are given below:

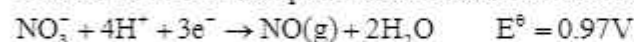

The number of metal(s) which will be oxidized by  $\text{NO}_3^-$  in aqueous solution is \_\_\_\_\_

Sol. 3

Metal +  $\text{NO}_3^- \rightarrow$  Metal Nitrate

(V, Fe, Ag)



Less value of reaction potential than 0.97 volt.

Answer 3

Topic : Solid State

Sub Topic : Types of Crystal System

Level : Tough

82. Number of crystal system from the following where body centred unit cell can be found, is \_\_\_\_\_  
Cubic, tetragonal, orthorhombic, hexagonal, rhombohedral, monoclinic, triclinic

Sol. 3

BCC present in  $\rightarrow$  Cubic, Tetragonal orthorhombic

Topic : Carbonyl

Sub Topic : Chemical Properties

Level : Easy

83. Among the following the number of compounds which will give positive iodoform reaction is \_\_\_\_\_

(a) 1-Phenylbutan-2-one

(b) 2-Methylbutan-2-ol

(c) 3-Methylbutan-2-ol

(d) 1-Phenylethanol

(e) 3,3-dimethylbutan-2-one

(f) 1-Phenylpropan-2-ol

Sol. 4

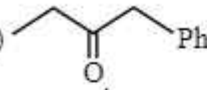
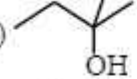
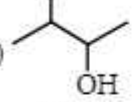
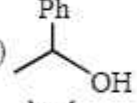
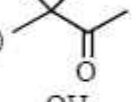
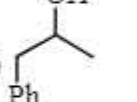
	Iodo form test
(a) 	-NO
(b) 	-NO
(c) 	-Yes
(d) 	-Yes
(e) 	-Yes
(f) 	-Yes

For carbonyl compound  $\begin{array}{|c|} \hline \text{C}-\text{CH}_3 \\ \hline \parallel \\ \text{O} \end{array}$  for alcohol  $\begin{array}{|c|} \hline \text{CH}-\text{CH}_3 \\ \hline | \\ \text{OH} \end{array}$  should be present for iodoform test.

Topic : Nitrogen Contain

Sub Topic : Isomerism

Level : Moderate

84. Number of isomeric aromatic amines with molecular formula  $\text{C}_8\text{H}_{11}\text{N}$ , which can be synthesized by Gabriel Phthalimide synthesis is \_\_\_\_\_

Sol. 5

By Gabriel phthalimide synthesis  $\rightarrow$  i-amine is prepared

$\text{C}_8\text{H}_{11}\text{N} \rightarrow$  Should be aromatic & i-amine.

$$\text{Du} = \text{C} + 1 - \frac{\text{H} - \text{N}}{2}$$

$$= 8 + 1 - \frac{11 - 1}{2}$$

$$= 9 - \frac{10}{2} = 9 - 5 = 4 \rightarrow \text{it means benzene ring}$$

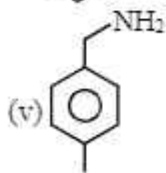
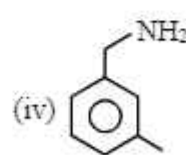
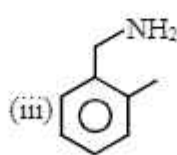
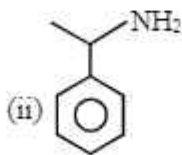
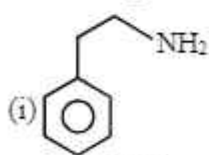

**Topic** : Liquid Solution  
**Sub Topic** : Osmotic Pressure  
**Level** : Easy

85. Consider the following pairs of solution which will be isotonic at the same temperature. The number of pairs of solutions is/are \_\_\_\_\_

- A. 1 M aq. NaCl and 2 M aq. Urea
- B. 1 M aq. CaCl<sub>2</sub> and 1.5 M aq. KCl
- C. 1.5 M aq. AlCl<sub>3</sub> and 2 M aq. Na<sub>2</sub>SO<sub>4</sub>
- D. 2.5 M aq. KCl and 1 M aq. Al<sub>2</sub>(SO<sub>4</sub>)<sub>3</sub>

**Sol.** 4

- A. 1 M aq. NaCl  $\Rightarrow$  2 M aq. Ions  
 2 M aq. Urea  $\Rightarrow$  2 M aq. Urea } Isotonic
- B. 1 M aq. CaCl<sub>2</sub>  $\Rightarrow$  3 M aq. Ions  
 1.5 M aq. KCl  $\Rightarrow$  3 M aq. Ions } Isotonic
- C. 1.5 M aq. AlCl<sub>3</sub>  $\Rightarrow$  6 M aq. Ions  
 2 M aq. Na<sub>2</sub>SO<sub>4</sub>  $\Rightarrow$  6 M aq. Ions } Isotonic
- D. 2.5 M aq. KCl  $\Rightarrow$  5 M aq. Ions  
 1 M aq. Al<sub>2</sub>(SO<sub>4</sub>)<sub>3</sub>  $\Rightarrow$  5 M aq. Ions } Isotonic

**Topic** : Surface Chemistry  
**Sub Topic** : Classification of Colloids  
**Level** : Easy

86. The number of colloidal systems from the following, which will have 'liquid' as the dispersion medium, is \_\_\_\_\_

Gem stones, paints, smoke, cheese, milk, hair cream, insecticide sprays, froth, soap lather

**Sol.** 5

**Liquid dispersion medium**  
 Paints, milk, hair cream, froth, soap lather

**Topic** : Solid State  
**Sub Topic** : Classification of Solid  
**Level** : Moderate

87. In an ice crystal, each water molecule is hydrogen bonded to \_\_\_\_\_ neighbouring molecules.

**Sol.** 2

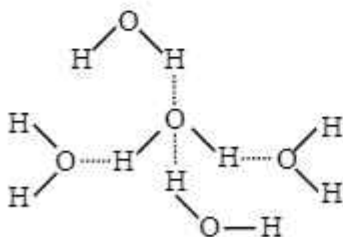

**Topic : Thermochemistry**  
**Sub Topic : Heat of Combustion**  
**Level : Moderate**

88. Consider the following data  
 Heat of combustion of  $H_2(g)$  =  $-241.8 \text{ kJ mol}^{-1}$   
 Heat of combustion of  $C(s)$  =  $-393.5 \text{ kJ mol}^{-1}$   
 Heat of combustion of  $C_2H_5OH(l)$  =  $-1234.7 \text{ kJ mol}^{-1}$   
 The heat of formation of  $C_2H_5OH(l)$  is  $(-)$  \_\_\_\_\_  $\text{kJ mol}^{-1}$  (Nearest integer).

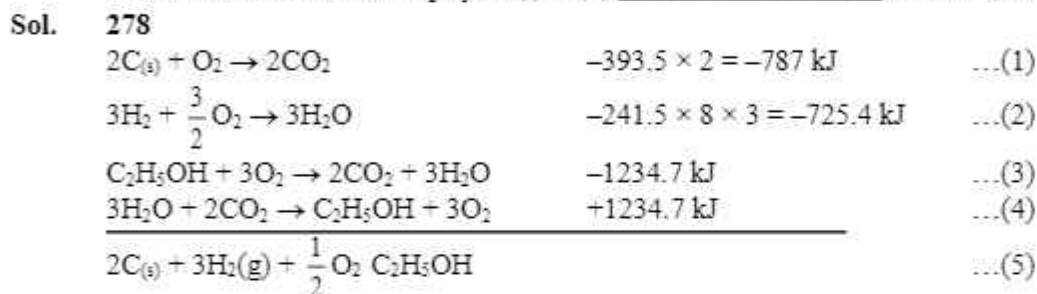

$$\begin{aligned} \text{eq (5)} &= \text{eq (1)} + \text{eq (2)} + \text{eq (4)} \\ &= (-787) + (-725.4) + (1234.7) \\ &= -277.7 = 278 \end{aligned}$$

**Topic : Chemical Equilibrium**  
**Sub Topic : Dissociation**  
**Level : Tough**

89. The equilibrium composition for the reaction  $PCl_3 + Cl_2 \rightleftharpoons PCl_5$  at 298 K is given below:  
 $[PCl_3]_{eq} = 0.2 \text{ mol L}^{-1}$ ,  $[Cl_2]_{eq} = 0.1 \text{ mol L}^{-1}$ ,  $[PCl_5]_{eq} = 0.40 \text{ mol L}^{-1}$   
 If 0.2 mol of  $Cl_2$  is added at the same temperature, the equilibrium concentrations of  $PCl_5$  is \_\_\_\_\_  $\times 10^{-2} \text{ mol L}^{-1}$   
 Given:  $K_c$  for the reaction at 298 K is 20

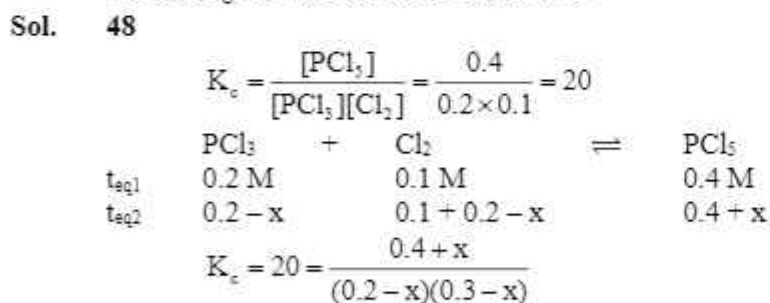

After solving by quadratic equation. We can get value of x.  
 $x = 0.084$

$$\begin{aligned} [PCl_5] &= 0.4 + x \\ &= 0.4 + 0.084 \\ &= 0.484 = 48.4 \times 10^{-2} \end{aligned}$$

Ans. 48

90. The number of species having a square planar shape from the following is \_\_\_\_\_  
 $XeF_4, SF_4, SiF_4, BF_4^-, BrF_4^-, [Cu(NH_3)_4]^{2+}, [FeCl_4]^{2-}, [PtCl_4]^{2-}$

