

SECTION - A

Multiple Choice Questions: This section contains 20 multiple choice questions. Each question has 4 choices (1), (2), (3) and (4), out of which **ONLY ONE** is correct.

Choose the correct answer:

1. The ratio of molar specific heat capacity at constant pressure (C_P) to that at constant volume (C_V) varies with temperature (T) as : [Assume temperature to be low]

- (1) T^0 (2) $T^{1/2}$
 (3) T (4) $T^{3/2}$

Answer (1)

Sol. $\frac{C_P}{C_V} = \frac{f+2}{f} = \gamma = 1 + \frac{2}{f} = \text{constant}$

We take ' f ' to be constant for molecule at low temperature.

$$\frac{C_P}{C_V} \propto T^0$$

2. If n : Number density of charge carriers
 A : Cross-sectional area of conductor
 q : Charge on each charge carrier
 I : Current through the conductor
 then the expression of drift velocity is

- (1) $\frac{nAq}{I}$ (2) $\frac{I}{nAq}$
 (3) $nAqI$ (4) $\frac{IA}{nq}$

Answer (2)

Sol. We Know $I = nAe v_d$

$$\Rightarrow v_d = \frac{I}{nAq}$$

3. If R , X_L and X_C denote resistance, inductive reactance and capacitive reactance respectively. Then which of the following options shows the dimensionless physical quantity.

- (1) $\frac{X_L X_C}{R}$ (2) $\frac{R}{\sqrt{X_L X_C}}$
 (3) $\frac{R}{X_L X_C}$ (4) $\frac{R}{(X_L X_C)^2}$

Answer (2)

Sol. $X_L = \text{Inductive reactance} = [R] = \text{dimension of } R$
 $X_C = \text{Capacitive reactance} = [R] = \text{dimension of } R$
 $R = \text{Resistance}$

$$\frac{R}{\sqrt{X_L X_C}} = \text{dimensionless}$$

4. A drop of water of 10 mm radius is divided into 1000 droplets. If surface tension of water surface is equal to 0.073 J/m² then increment in surface energy while breaking down the bigger drop in small droplets as mentioned is equal to

- (1) $8.25 \times 10^{-5} \text{ J}$ (2) $9.17 \times 10^{-4} \text{ J}$
 (3) $9.17 \times 10^{-5} \text{ J}$ (4) $8.25 \times 10^{-4} \text{ J}$

Answer (4)

Sol. Let the radius of one small droplet is r then

$$1000 \frac{4}{3} \pi r^3 = \frac{4}{3} \pi (10)^3$$

$$\Rightarrow r = 1 \text{ mm}$$

$$U_f = 1000 \cdot 4\pi r^2 \cdot T = 1000 \times 4\pi \times 10^{-6} \times 0.073 = 9.17 \times 10^{-4} \text{ J}$$

$$U_i = 4\pi \times (10^{-2})^2 \cdot T = 9.17 \times 10^{-5} \text{ J}$$

$$\text{So } \Delta U = 8.25 \times 10^{-4} \text{ J}$$

5. A force 200 N is exerted on a disc of mass 70 kg as shown. Find the normal reaction given by ground on the disc.

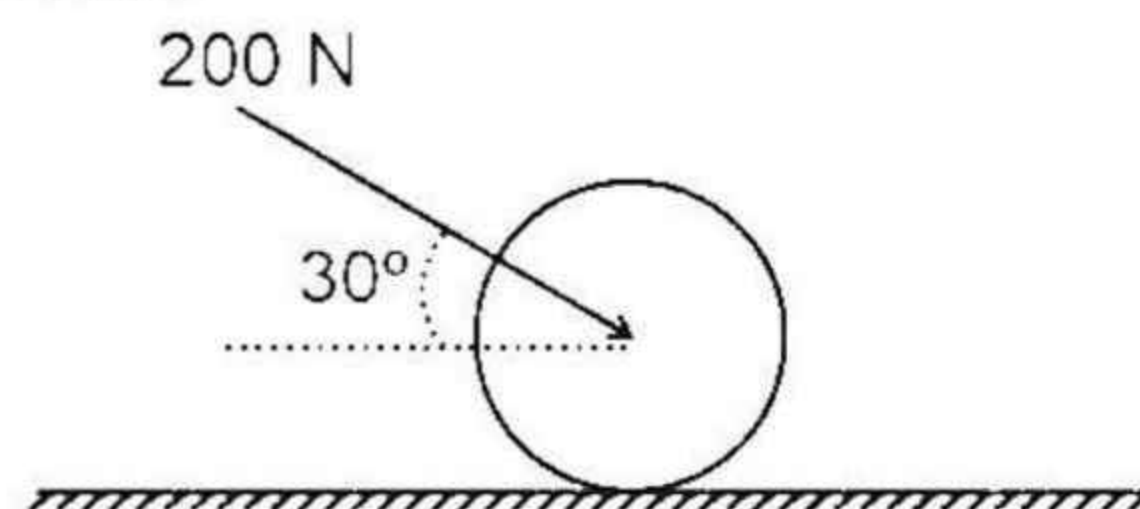

- (1) 200 N (2) 600 N
 (3) 800 N (4) $\frac{200}{\sqrt{3}} \text{ N}$

Answer (3)

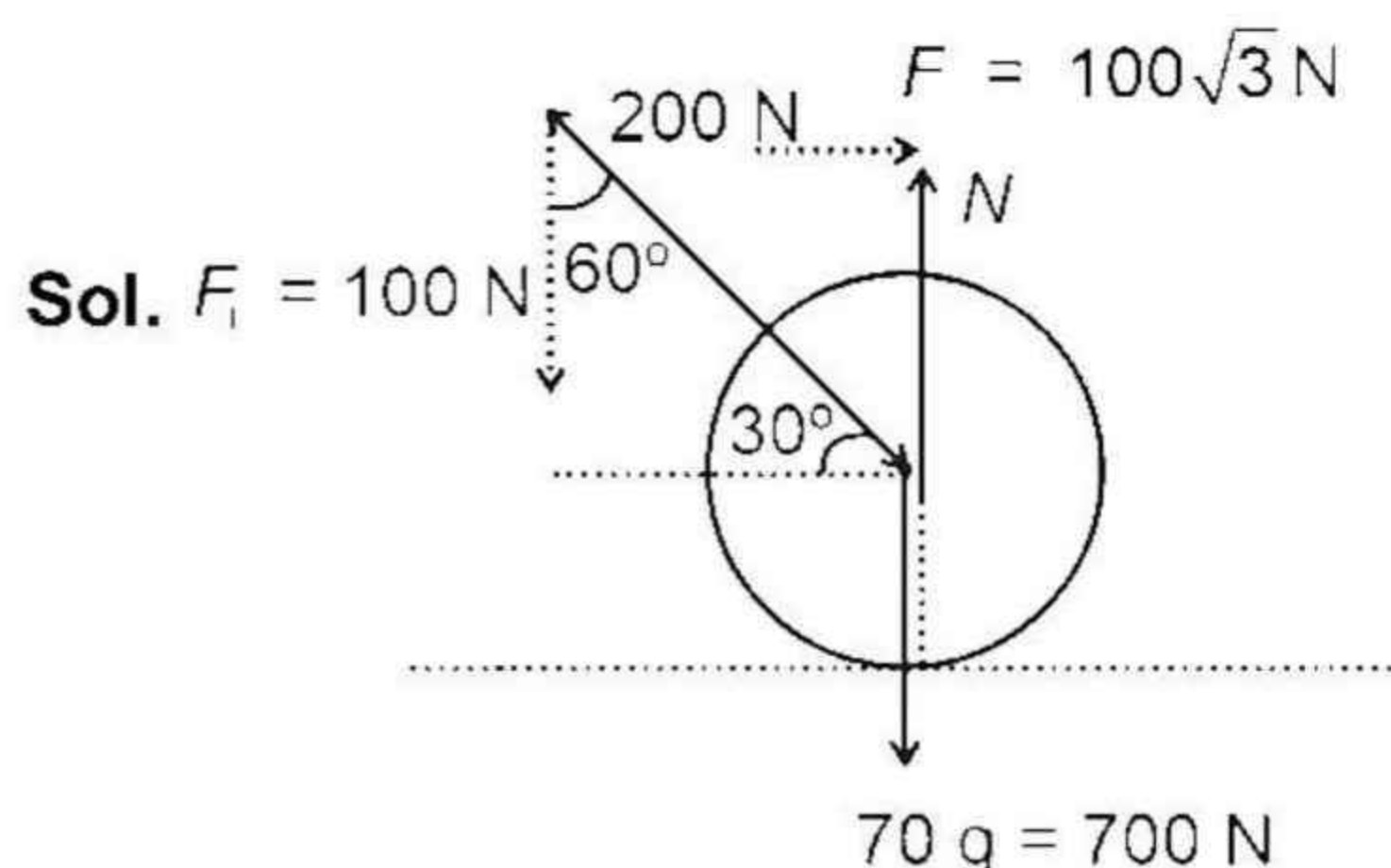

$$\begin{aligned} N &= Mg + F_{\perp} \\ &= 700 + 100 \\ &= 800 \text{ N} \end{aligned}$$

6. At depth d from surface of earth acceleration due to gravity is same as its value at height d above the surface of earth. If earth is a sphere of radius 6400 km, then value of d is equal to

- (1) 2975 km (2) 3955 km
 (3) 2525 km (4) 4915 km

Answer (2)

Sol. $g_0 \left(1 - \frac{d}{R}\right) = \frac{g_0}{\left(1 + \frac{d}{R}\right)^2}$

$$\left(1 - \frac{d}{R}\right) \left(1 + \frac{d}{R}\right)^2 = 1$$

On solving

$$\frac{d}{R} = 0, -\left(\frac{\sqrt{5}+1}{2}\right), \frac{\sqrt{5}-1}{2}$$

$$\text{So, } d = \frac{\sqrt{5}-1}{2} R$$

$$\Rightarrow d = 3955 \text{ km}$$

7. Which of the following graphs depicts the variation of electric potential with respect to radial distance from centre of a conducting sphere charged with positive charge.

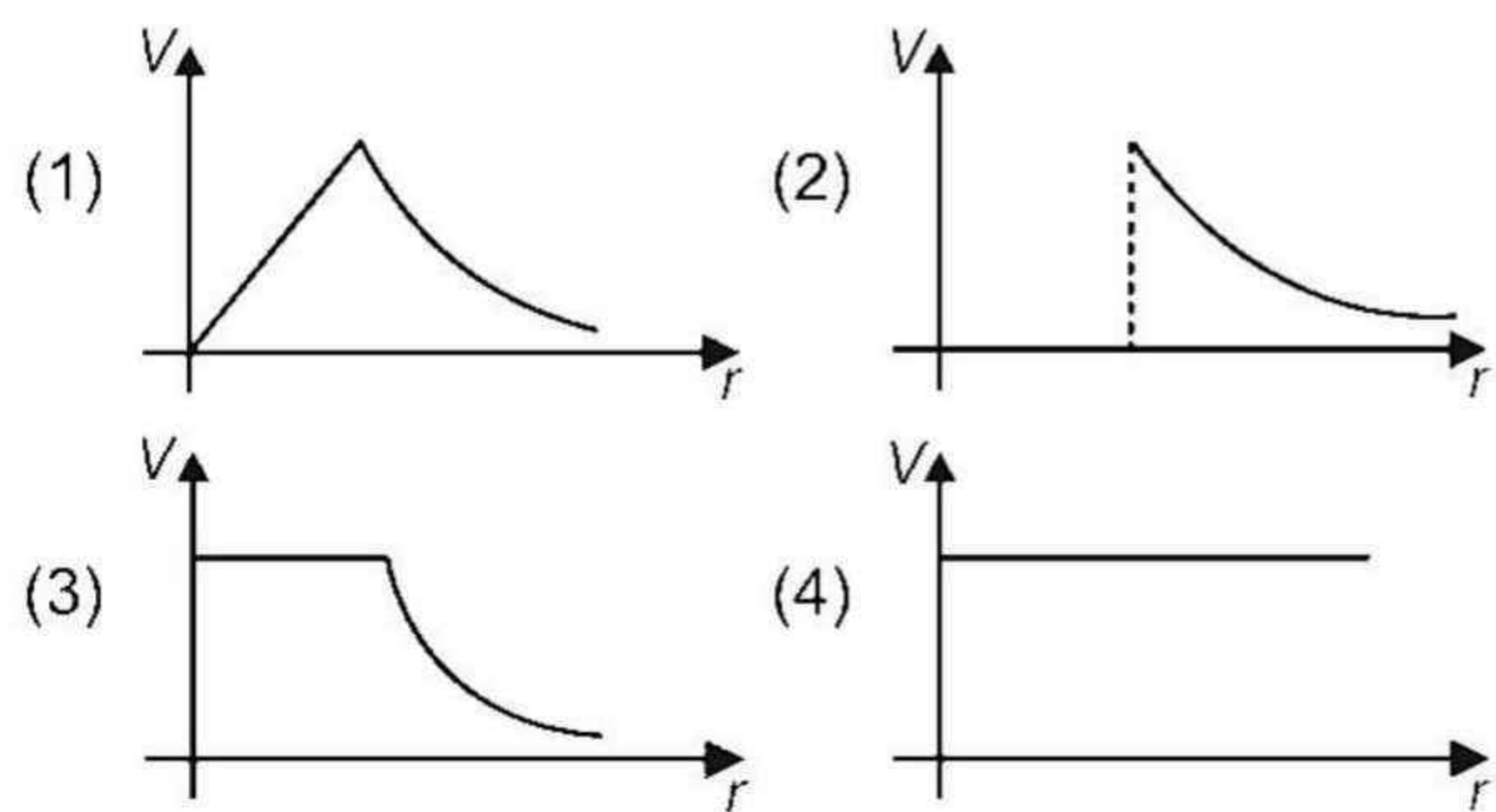

Answer (3)

Sol. $V(r) = \begin{cases} \frac{q}{4\pi\epsilon_0 R} & \text{if } r < R \\ \frac{q}{4\pi\epsilon_0 r} & \text{if } r > R \end{cases}$

Where r is radial distance and R is radius of sphere, as charge will be on the surface because the sphere is conducting. So graph will be

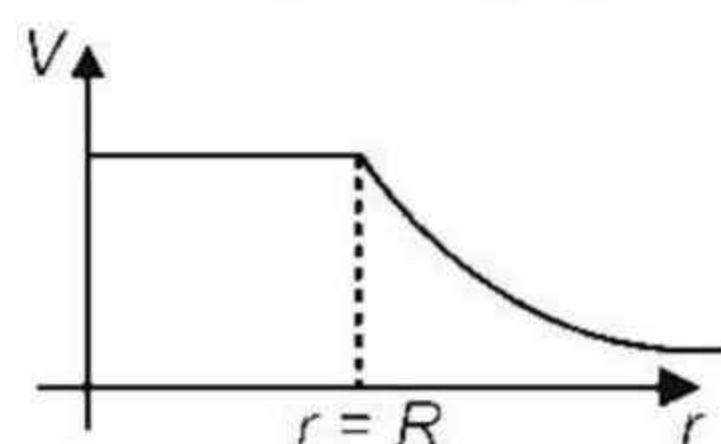

8. In a sample of hydrogen atoms, one atom goes through a transition $n = 3 \rightarrow$ ground state with emitted wavelength λ_1 . Another atom goes through a transition $n = 2 \rightarrow$ ground state with emitted wavelength λ_2 . Find $\frac{\lambda_1}{\lambda_2}$.

- (1) $\frac{6}{5}$ (2) $\frac{5}{6}$
 (3) $\frac{27}{32}$ (4) $\frac{32}{27}$

Answer (3)

Sol. $\frac{1}{\lambda_1} = RZ^2 \left[1 - \frac{1}{9}\right]$

$$\frac{1}{\lambda_2} = RZ^2 \left[1 - \frac{1}{4}\right]$$

$$\Rightarrow \frac{\lambda_1}{\lambda_2} = \frac{\frac{3}{4}}{\frac{8}{9}} = \frac{27}{32}$$

9. A block of mass m is connected to two identical springs of force constant K as shown. Find total number of oscillations of block per unit time.

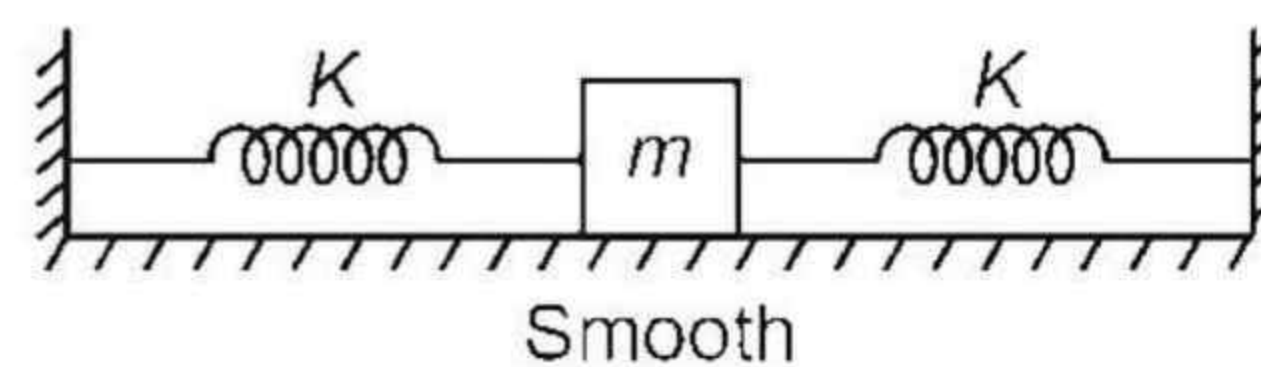

- (1) $2\pi\sqrt{\frac{2m}{K}}$ (2) $\frac{1}{2\pi}\sqrt{\frac{K}{m}}$
 (3) $2\pi\sqrt{\frac{m}{2K}}$ (4) $\frac{1}{2\pi}\sqrt{\frac{2K}{m}}$

Answer (4)

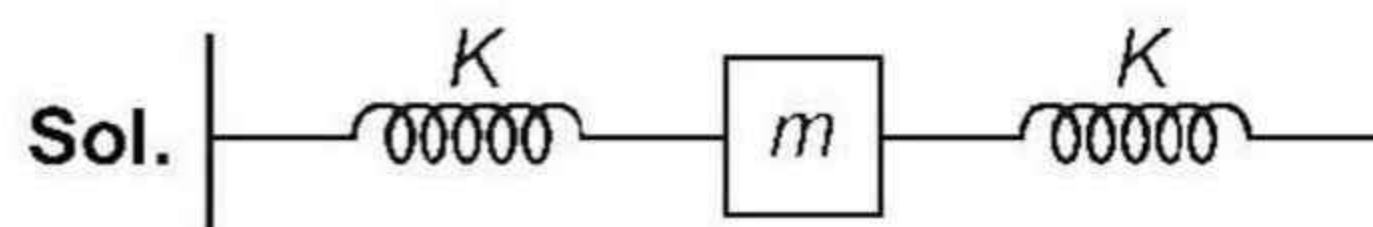

$$K_{eq} = 2K$$

$$\omega = \sqrt{\frac{K_{eq}}{m}} = \sqrt{\frac{2K}{m}}$$

$$f = \frac{\omega}{2\pi} = \frac{1}{2\pi}\sqrt{\frac{2K}{m}} \text{ oscillation per second.}$$

10. Consider the two statements:

Assertion : The beam of electrons shows wave nature and exhibits interference and diffraction.

Reason : Davisson-Germer experiment verified the wave nature of electrons.

- (1) Both are correct. Reason correctly explains assertion
 (2) Both are incorrect
 (3) Assertion is correct but Reason is incorrect
 (4) Both are correct. Reason does not explain assertion.

Answer (1)

Sol. Davisson Germer experiment verified wave nature of electrons.

Option (1) is correct.

11. A projectile is launched on horizontal surface such that if thrown with initial velocity of u , it has velocity of $\frac{\sqrt{3}u}{2}$ at maximum height. Then time of flight of the projectile is equal to

- (1) $\frac{\sqrt{3}u}{g}$ (2) $\frac{2u}{g}$
 (3) $\frac{u}{g}$ (4) $\frac{u}{2g}$

Answer (3)

Sol. $u \cos \theta = \frac{\sqrt{3}u}{2}$

$\Rightarrow \theta = \frac{\pi}{6}$ angle of projection

$$T = \frac{2u \sin \theta}{g} = \frac{u}{g}$$

12. A diatomic gas is taken from point A to point B in a thermodynamic process as described in the Pressure-Volume graph shown. The change in internal energy is equal to

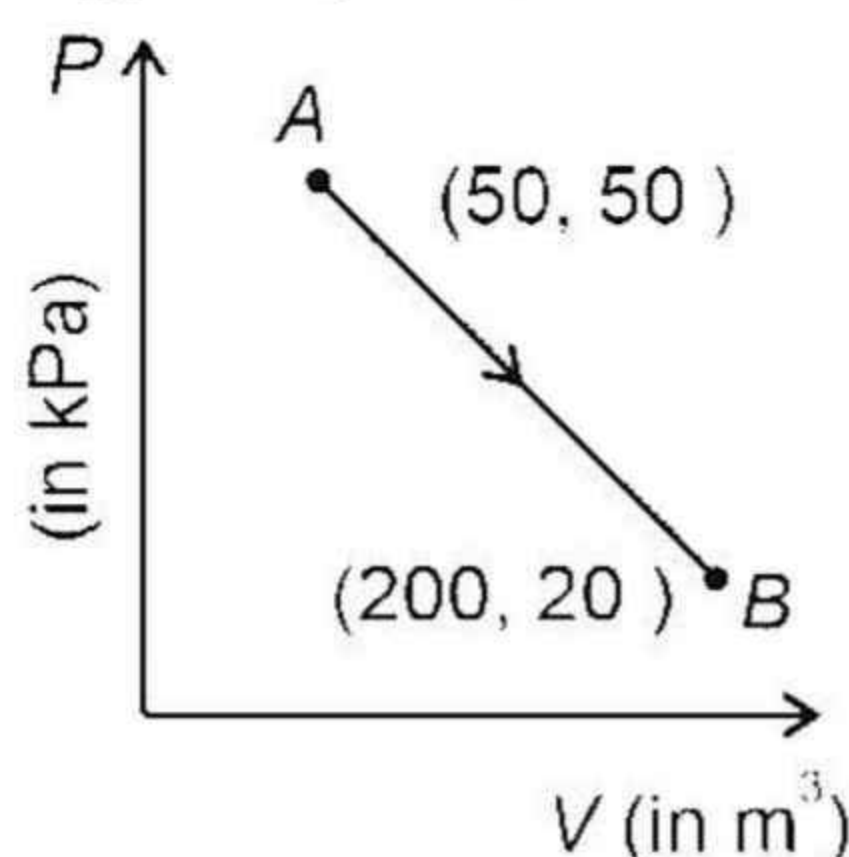

- (1) 3.75×10^6 J
 (2) 2.25×10^6 J
 (3) 7.5×10^6 J
 (4) 4.5×10^6 J

Answer (1)

Sol. $\Delta U = \frac{f}{2} nR\Delta T$
 $= \frac{5}{2} (P_f V_f - P_i V_i)$
 $= \frac{5}{2} (200 \times 20 \times 10^3 - 50 \times 50 \times 10^3) \text{ J}$
 $= \frac{5}{2} \times 1500 \times 10^3 \text{ J} = 3.75 \times 10^6 \text{ J}$

13. A conductor of length l and cross-sectional area A has drift velocity v_d when used across a potential difference V . When another conductor of same material and length l but double cross-sectional area than first is used across same potential difference than drift velocity is equal to

- (1) $\frac{V_d}{2}$ (2) v_d
 (3) $2v_d$ (4) $4v_d$

Answer (2)

Sol. $I = \eta e v_d A$

$$\frac{V}{2} = \eta e v_d A$$

$$\frac{VA}{\rho l} = \eta e v_d A$$

$\Rightarrow v_d$ is independent of area of cross-sectional of conductor.

14. A swimmer swims perpendicular to river flow and reaches point B. If velocity of swimmer in still water is 4 km/h, find velocity of river flow.

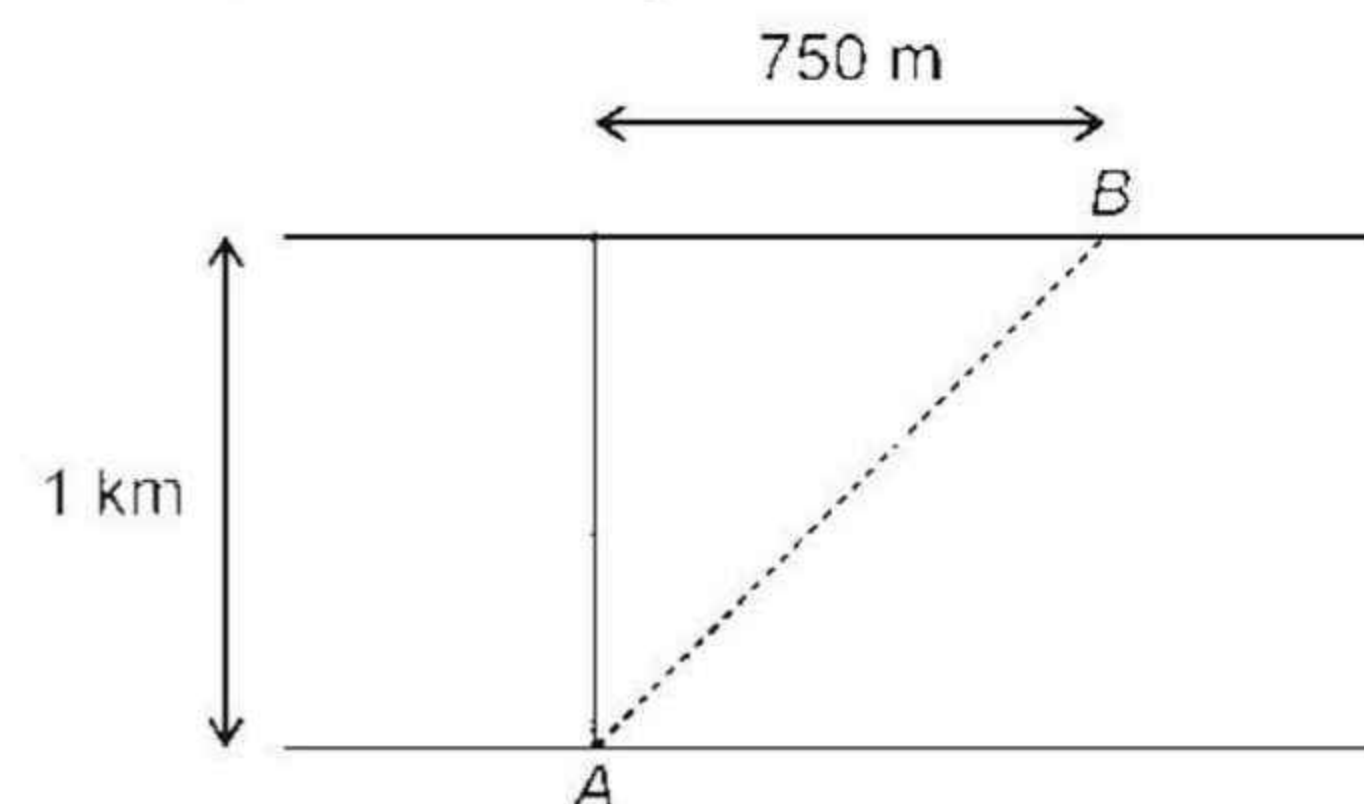

- (1) 3 km/hr (2) 5 km/hr
 (3) 2 km/hr (4) 6 km/hr

Answer (1)

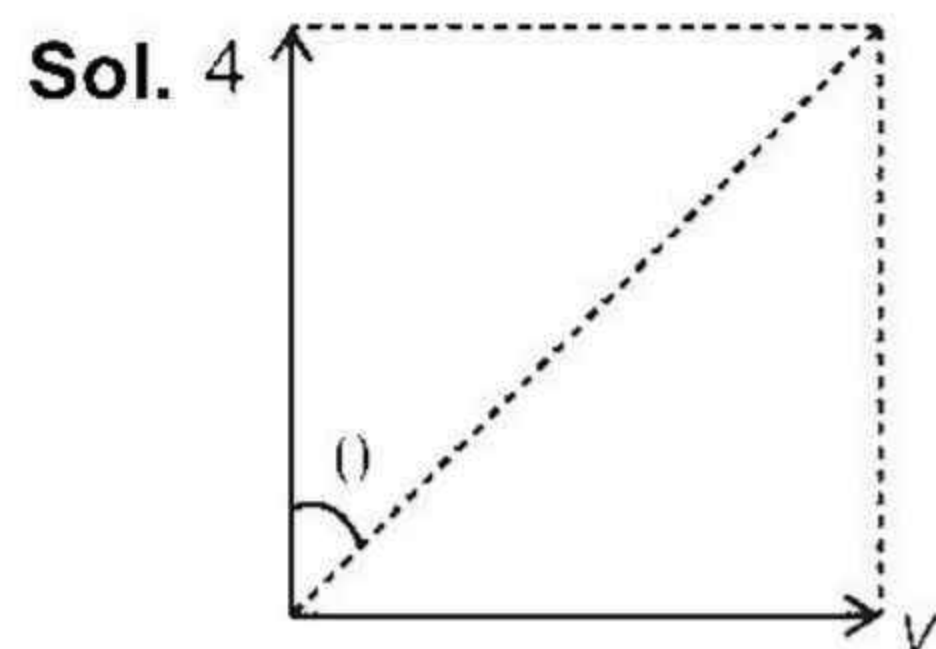

$$\Rightarrow \frac{v}{4} = \tan \theta = \frac{750}{1000}$$

$$\Rightarrow v = 3 \text{ km/hr}$$

15. A bar magnet with magnetic moment of 5 Am^2 is lying at stable equilibrium in external uniform magnetic field of strength 0.4 T . Work done in slowly rotating the bar magnet to the position of unstable equilibrium is equal to

- (1) 1 J (2) 2 J
 (3) 3 J (4) 4 J

Answer (4)

Sol. $U_i = -MB \cos 0^\circ$

$$U_f = -MB \cos 180^\circ$$

so, $W = \Delta U$

$$= 2MB$$

$$= 2 \times 5 \times 0.4$$

$$= 4 \text{ J}$$

16. Unpolarised light (of intensity I_0) is incident on a polarizer A and subsequently on polarizer B whose pass axis is perpendicular to that of A. Now a polarizer C is introduced between A and B such that pass axis of C is at 45° with pass axis of A. Find intensity that comes out of B.

- (1) $\frac{I_0}{8}$
 (2) $\frac{I_0}{4}$
 (3) Zero
 (4) $\frac{3I_0}{8}$

Answer (1)

Sol. $I_{\text{net}} = I_0 \times \frac{1}{2} \times \cos^2 45^\circ \times \cos^2 45^\circ$

$$= \frac{I_0}{8}$$

SECTION - B

Numerical Value Type Questions: This section contains 10 questions. In Section B, attempt any five questions out of 10. The answer to each question is a **NUMERICAL VALUE**. For each question, enter the correct numerical value (in decimal notation, truncated/rounded-off to the second decimal place; e.g., 06.25, 07.00, -00.33, -00.30, 30.27, -27.30) using the mouse and the on-screen virtual numeric keypad in the place designated to enter the answer.

21. A solid sphere is rolling on a smooth surface with kinetic energy $= 7 \times 10^{-3} \text{ J}$. If mass of the sphere is 1 kg, find the speed of centre of mass in cm/s. (Consider pure rolling)

Answer (10.00)

Sol. $\frac{1}{2}mv_{\text{cm}}^2 + \frac{1}{2} \cdot \frac{2}{5}mv^2 = 7 \times 10^{-3}$

$$\Rightarrow \frac{7}{10}mv^2 = \frac{7}{1000}$$

$$\Rightarrow v = \frac{1}{10} \text{ m/s} = 10 \text{ cm/s}$$

22. A lift of mass 500 kg starts moving downwards with initial speed 2 m/s and accelerates at 2 ms^{-2} . The kinetic energy of the lift when it has moved 6 m down is _____ kJ.

Answer (07.00)

Sol. $u = 2 \text{ m/s}$

$$a = 2 \text{ m/s}^2$$

$$s = 6 \text{ m}$$

$$v^2 - u^2 = 2as$$

$$\Rightarrow v^2 = u^2 + 2as = 4 + 2 \times 2 \times 6 = 28$$

$$\text{K.E.} = \frac{1}{2}MV^2 = \frac{1}{2} \times 500 \times (28)$$

$$= 500 \times 14$$

$$= 7000 \text{ J}$$

$$= 7 \text{ kJ}$$

23. Electric field in a region is $4000x^2\hat{i}$ N/C . The flux through the cube is $\frac{x}{5}$ Nm²/C . Find x.

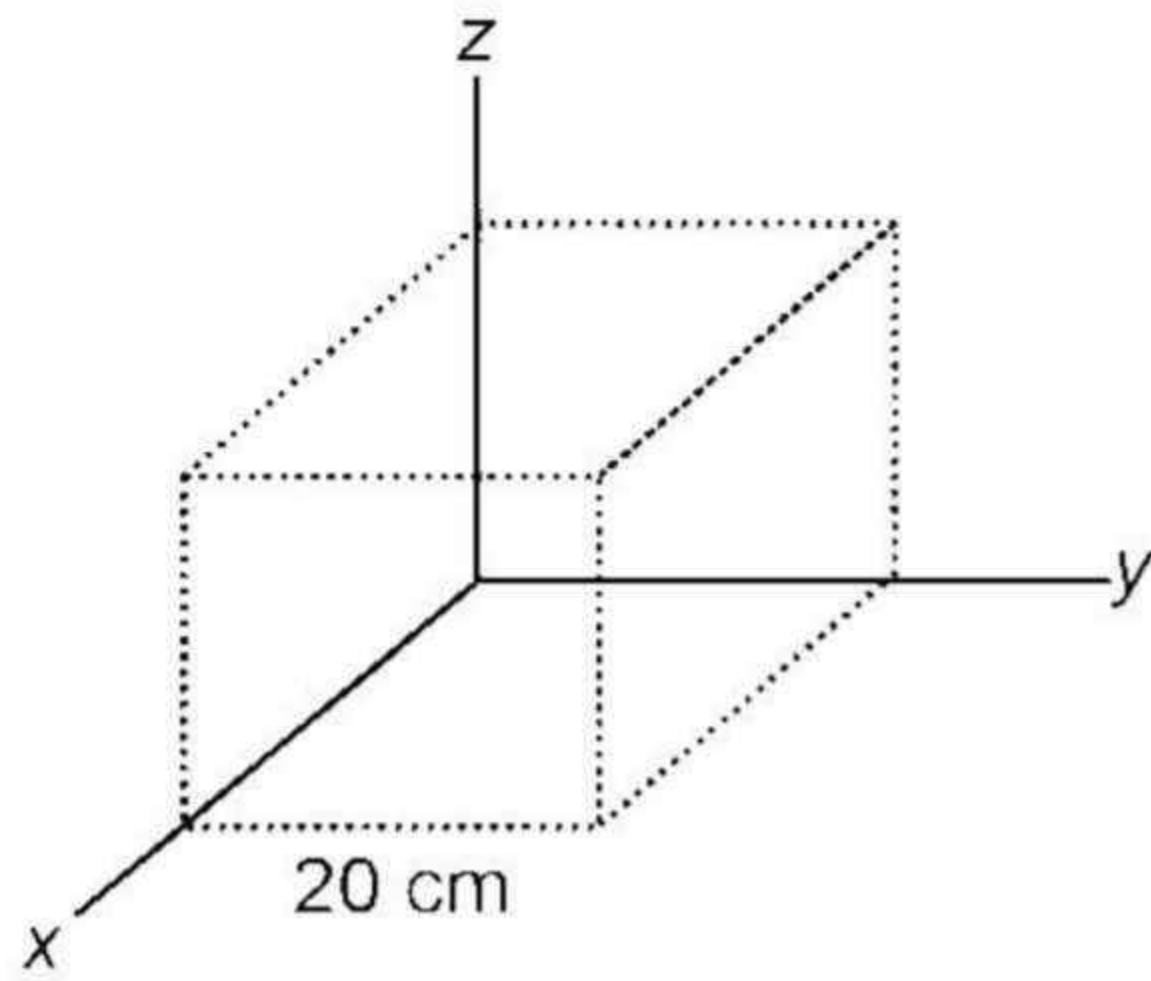

Answer (32)

Sol. $\phi = 4000(0.2)^2 \times \text{Area}$
 $= 4000(0.2)^2 \times (0.2)^2$
 $= \frac{4000 \times 16}{10000}$
 $= 6.4 \text{ Nm}^2/\text{C}$

24. For an series LCR circuit across an A.C source, current and voltage are in same phase. Given the resistance of 20Ω and voltage of the source is 220 V . Find current (in A) in the circuit.

Answer (11.00)

Sol. The given circuit is in resonance

$$\therefore i = \frac{220}{20} = 11 \text{ A}$$

25. For a particle performing SHM, maximum potential energy is 25 J . The kinetic energy (in J) at half the amplitude is $\frac{x}{4}$. Find x

Answer (75.00)

Sol. $\text{KE} = \frac{1}{2}kA^2 - \frac{1}{2}k\left(\frac{A}{2}\right)^2$
 $= \frac{1}{2}kA^2 \left[\frac{3}{4}\right]$
 $= \frac{3}{4} \times 25 \text{ J}$
 $= \frac{75}{4} \text{ J}$

26. The current through a 5Ω resistance remains same, irrespective of its connection across series or parallel combination of two identical cells. Find the internal resistance (in Ω) of the cell.

Answer (05.00)

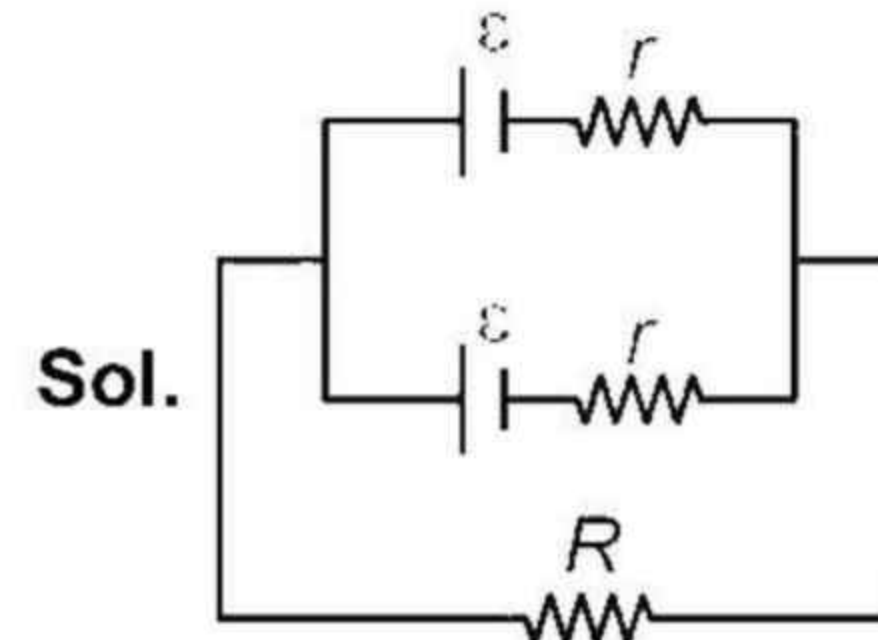

$$\frac{\epsilon_{\text{eq}}}{\left(\frac{r}{2}\right)} = \frac{\epsilon}{r} + \frac{\epsilon}{r}$$

$$\epsilon_{\text{eq}} = \epsilon$$

$$r_{\text{eq}} = \left(\frac{r}{2}\right)$$

$$\text{current} = i = \frac{\epsilon}{R + \left(\frac{r}{2}\right)}$$

When connected in series

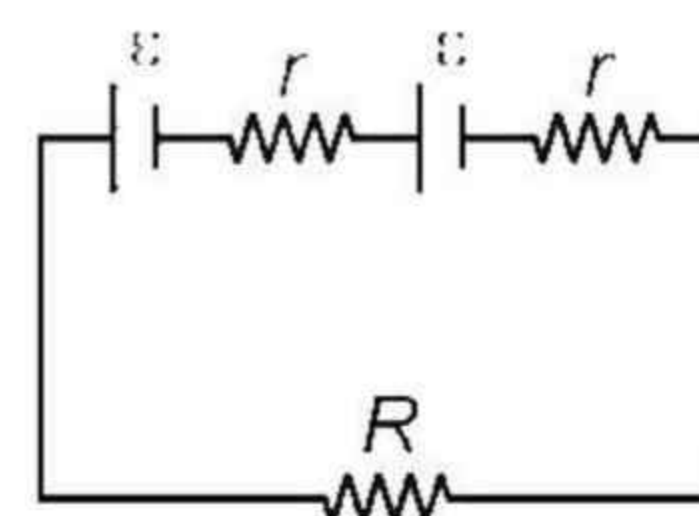

$$\epsilon_{\text{eq}} = 2\epsilon$$

$$i = \left(\frac{2\epsilon}{R + 2r}\right)$$

$$\Rightarrow \frac{\epsilon}{R + \frac{r}{2}} = \frac{2\epsilon}{R + 2r}$$

$$\Rightarrow R + 2r = 2R + r$$

$$\Rightarrow \boxed{r = R = 5 \Omega}$$

SECTION – A

Multiple Choice Questions: This section contains 20 multiple choice questions. Each question has 4 choices (1), (2), (3) and (4), out of which **ONLY ONE** is correct.

Choose the correct answer :

1. Electronic configuration of Nd^{2+} is
 (1) $4f^2$
 (2) $4f^3$
 (3) $4f^4$
 (4) $4f^5$

Answer (3)

Sol. $\text{Nd}^{2+} = [\text{Xe}] 4f^4$

2. Following values of K (Rate constants) are given at different temperatures. Find out (E_a) Activation energy.
 $T = 200 \text{ K} \rightarrow K_1 = 0.03$
 $T = 300 \text{ K} \rightarrow K_2 = 0.05$
 (1) 2.548 kJ
 (2) 11.488 kJ
 (3) 1.106 kJ
 (4) 51.437 kJ

Answer (1)

Sol.
$$\log\left(\frac{0.05}{0.03}\right) = \frac{E_a}{2.303 \times 8.314} \left(\frac{1}{200} - \frac{1}{300}\right)$$

$$= \frac{E_a}{2.303 \times 8.314} \left(\frac{1}{600}\right)$$

$E_a = 2.548 \text{ kJ}$

3. Basic strength of oxides of V
 V_2O_3 V_2O_5 V_2O_4
 (1) $\text{V}_2\text{O}_3 < \text{V}_2\text{O}_5 < \text{V}_2\text{O}_4$
 (2) $\text{V}_2\text{O}_3 < \text{V}_2\text{O}_4 < \text{V}_2\text{O}_5$
 (3) $\text{V}_2\text{O}_3 > \text{V}_2\text{O}_4 > \text{V}_2\text{O}_5$
 (4) $\text{V}_2\text{O}_3 = \text{V}_2\text{O}_4 = \text{V}_2\text{O}_5$

Answer (3)

Sol. As oxidation state of V increases than other acidic nature increases

Correct basic order is $\text{V}_2\text{O}_3^{+3} > \text{V}_2\text{O}_4^{+4} > \text{V}_2\text{O}_5^{-5}$

4. XeF_4 , SF_4 and BrCl_3 show hybridizations respectively
 (1) sp^3 , sp^3 , sp^3
 (2) dsp^2 , sp^3 , sp^3
 (3) sp^3d^2 , sp^3d , sp^3d
 (4) d^2sp^2 , sp^3d , sp^3d

Answer (3)

Sol.

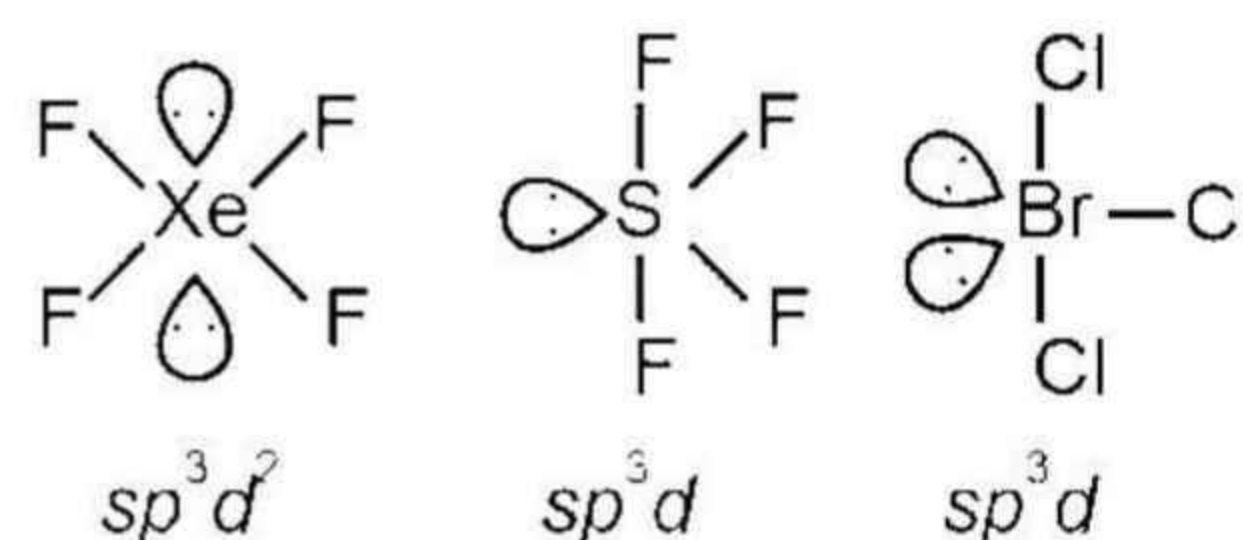

5. $\text{Cu}^{2+} + \text{I}^- \rightarrow \text{A} \xrightarrow{\Delta} \text{B} + \text{C}$

B and C are

- (1) I_2 , Cu_2I_2
 (2) $[\text{CuI}_4]$
 (3) CuI_3^-
 (4) I^- , CuI_2

Answer (1)

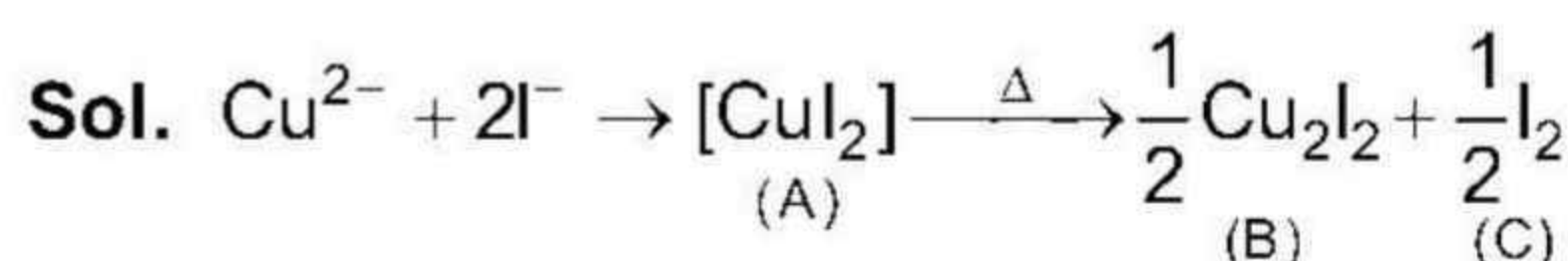

\therefore Products (B) and (C) are Cu_2I_2 and I_2 respectively.

6. When phenol reacts with Br_2 in low polarity solvent, it produces as a major product _____?

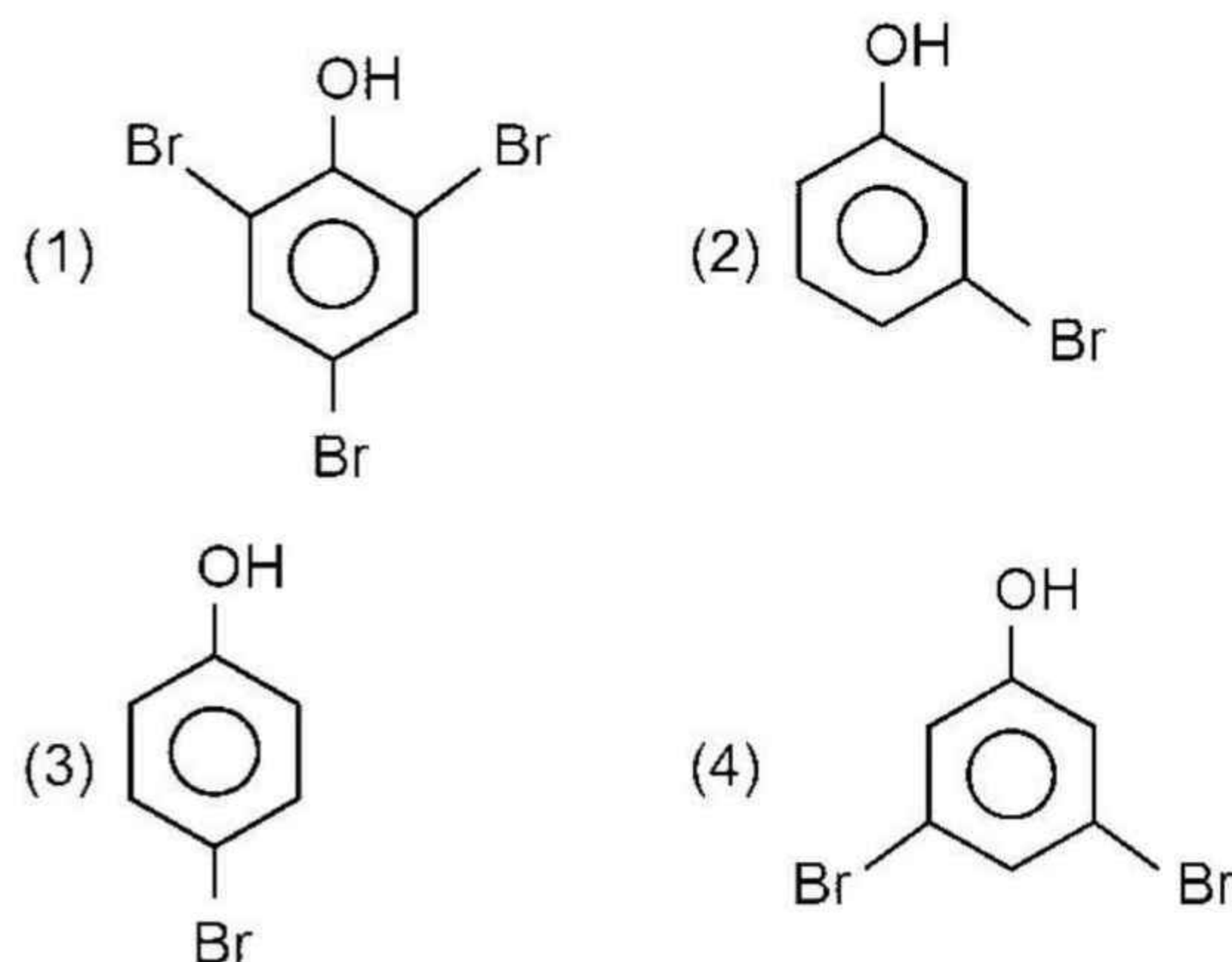

Answer (3)

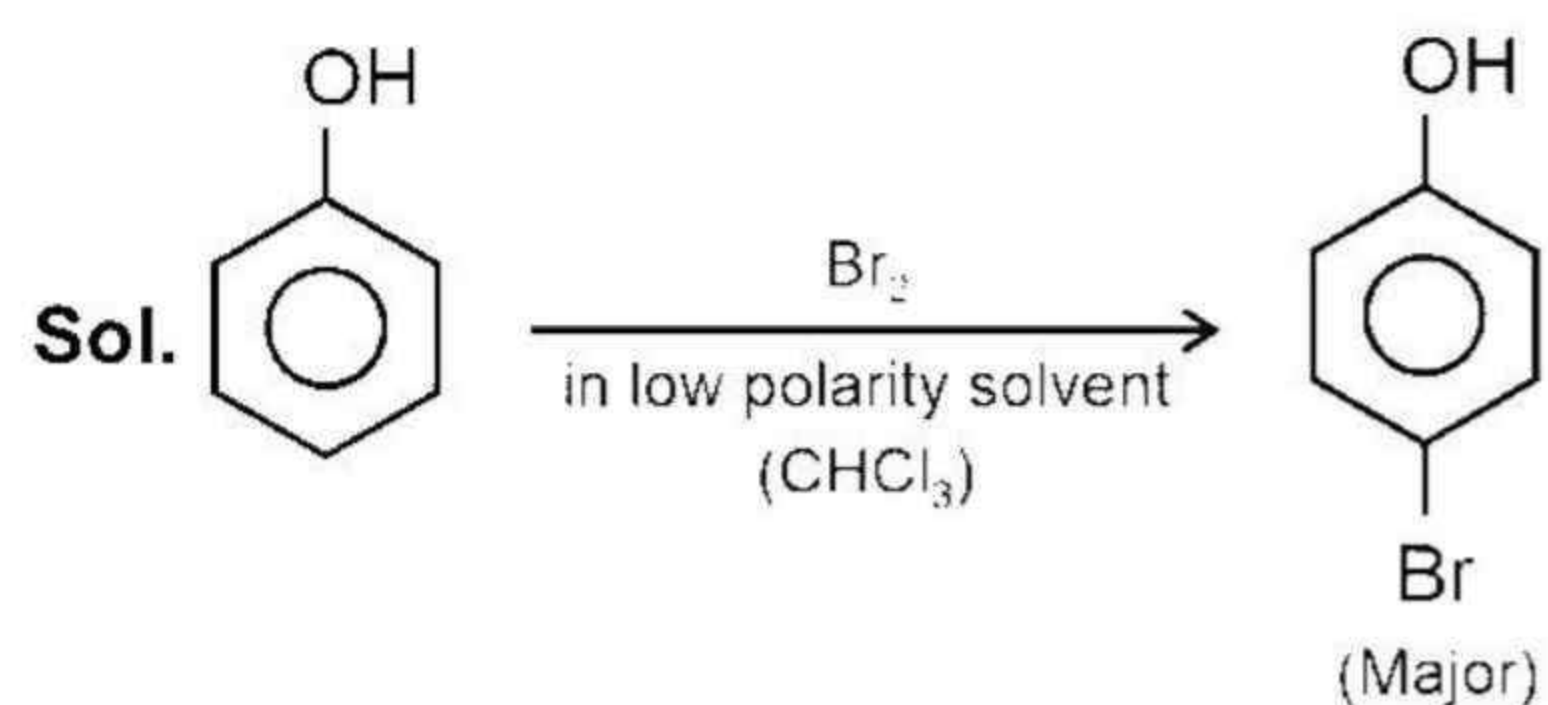

7. Choose the correct information regarding products obtained on electrolysis of Brine solution
- (1) Cl₂ at cathode (2) O₂ at cathode
 (3) H₂ at cathode (4) OH⁻ at anode

Answer (3)

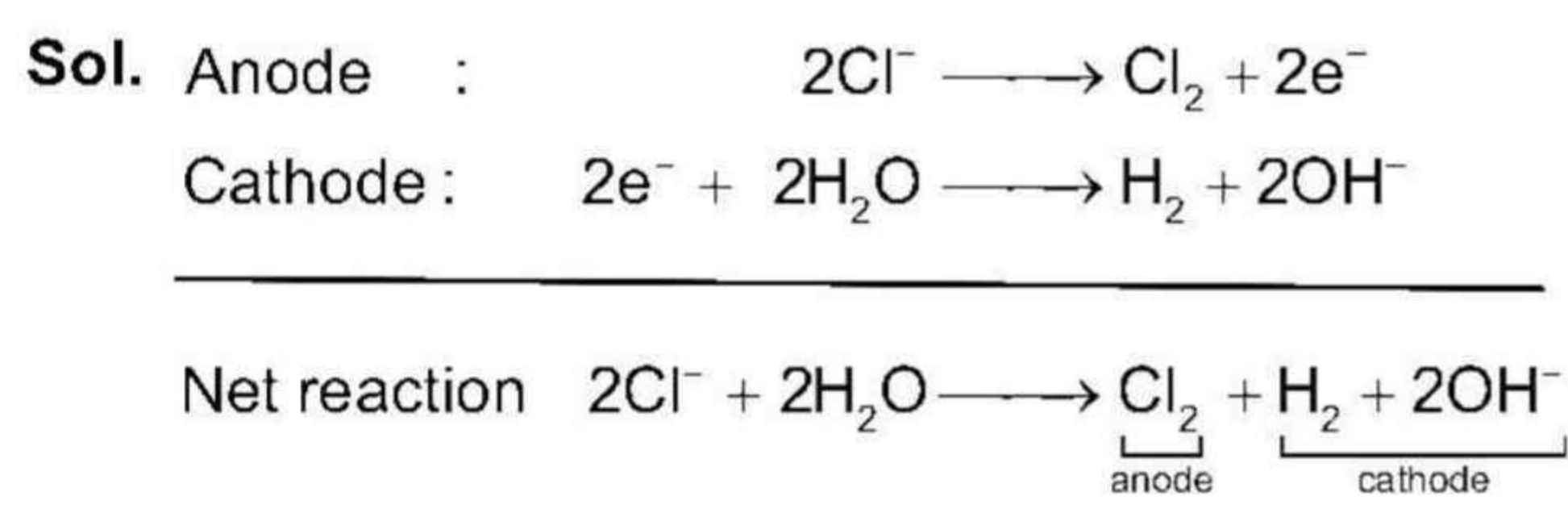

8. Melting point order of

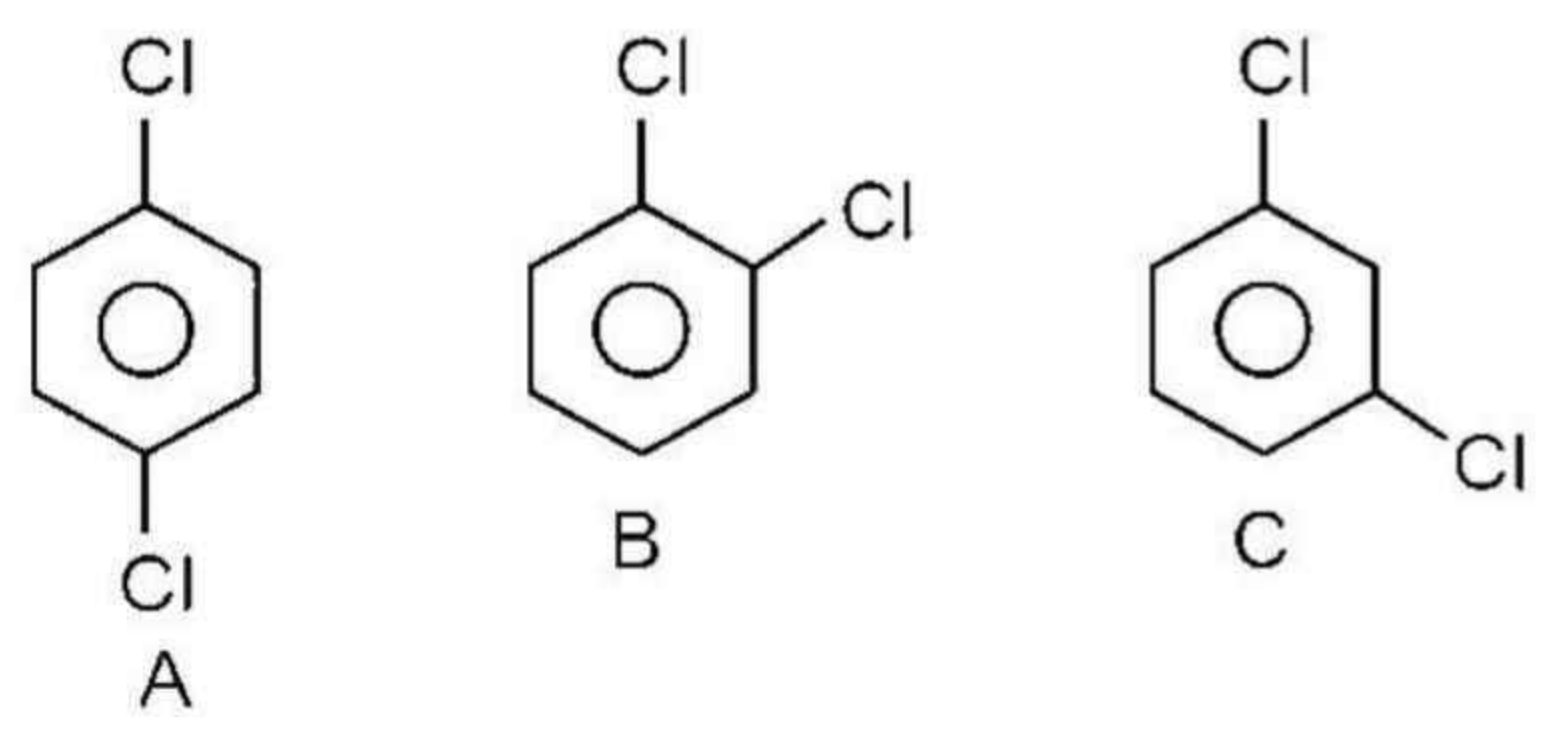

- (1) A > B > C
 (2) C > A > B
 (3) B > A > C
 (4) A > C > B

Answer (1)

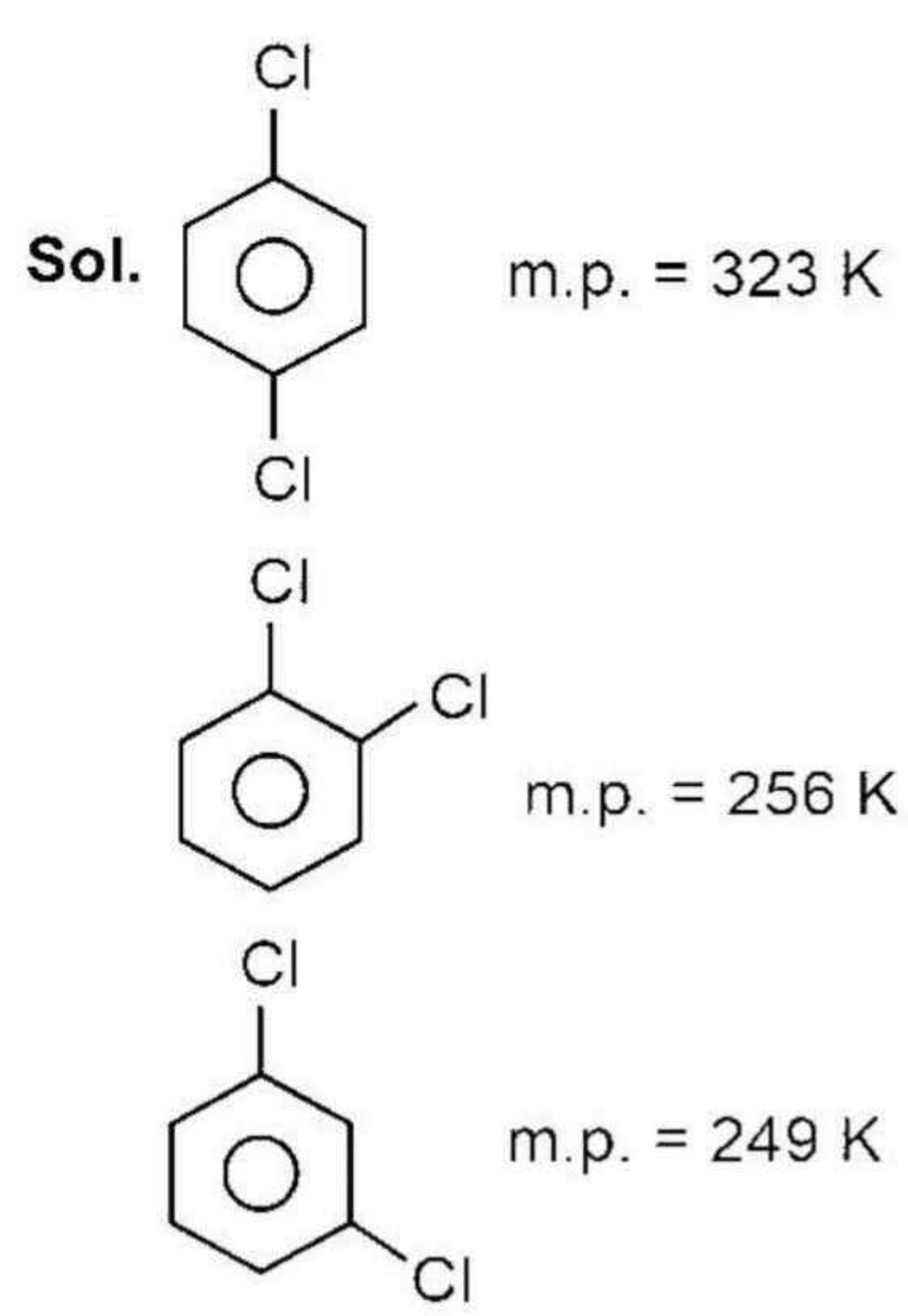

9. Consider the following reaction :

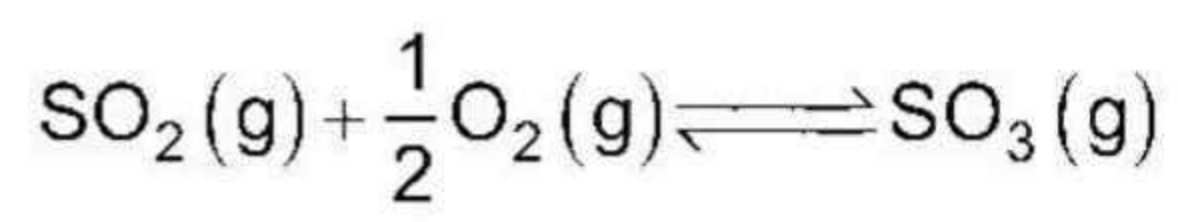

If $K_p = 2 \times 10^{12}$ and $K_c = x \times 10^{13}$, the value of x in terms of RT will be

- (1) $\frac{\sqrt{RT}}{4}$
 (2) $\frac{\sqrt{RT}}{5}$
 (3) $\frac{\sqrt{RT}}{10}$
 (4) $10\sqrt{RT}$

Answer (2)

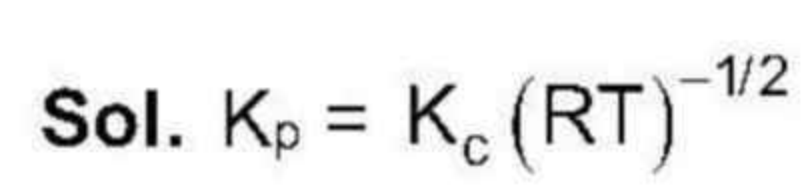

$$2 \times 10^{12} = x \times 10^{13} (\text{RT})^{-1/2}$$

$$x = \frac{2 \times 10^{12}}{10^{13} \times (\text{RT})^{-1/2}} = \frac{2\sqrt{RT}}{10} = \frac{\sqrt{RT}}{5}$$

10. Arrange the following ions in the increasing order of their ionic radii.

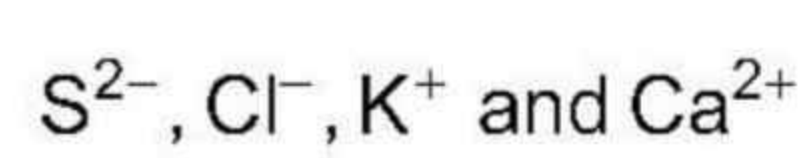

- (1) S²⁻ < Cl⁻ < K⁺ < Ca²⁺
 (2) Cl⁻ < S²⁻ < K⁺ < Ca²⁺
 (3) K⁺ < Ca²⁺ < Cl⁻ < S²⁻
 (4) Ca²⁺ < K⁺ < Cl⁻ < S²⁻

Answer (4)

Sol. The given ionic species are isoelectronic species. The radii of isoelectronic ionic species increases as the atomic of the ion decreases. Therefore, the correct increasing order of radii of ionic species is

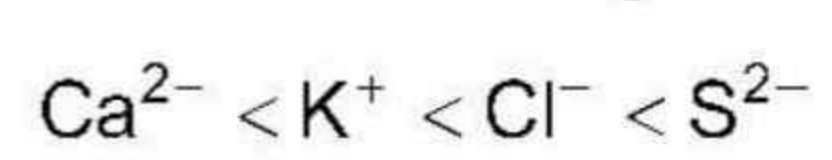

11. Which of the following option contains the compound which has highest sweetening value?

- (1) Aspartame
 (2) Saccharin
 (3) Sucralose
 (4) Alitame

Answer (4)

Sol. Alitame has the highest sweetening value.

12. Which of the following method is not a concentration of ore?

- (1) Electrolysis (2) Leaching
(3) Froth floatation (4) Hydraulic washing

Answer (1)

Sol. The following methods are commonly used for concentration of ore

1. Hydraulic washing
2. Leaching
3. Froth floatation

But electrolysis is used for refining of the crude metal.

13. In which of the following reactions, H_2O_2 acts as a reducing agent

- (1) $\text{H}_2\text{O}_2 + \text{Mn}^{2+} \rightarrow \text{MnO}_2 + \text{H}_2\text{O}$
(2) $\text{NaOCl} + \text{H}_2\text{O}_2 \rightarrow \text{NaCl} + \text{O}_2$
(3) $\text{Fe}^{2+} + \text{H}_2\text{O}_2 \rightarrow \text{Fe}^{3+} + \text{H}_2\text{O}$
(4) $\text{PbS} + \text{H}_2\text{O}_2 \rightarrow \text{PbSO}_4 + \text{H}_2\text{O}$

Answer (2)

Sol.

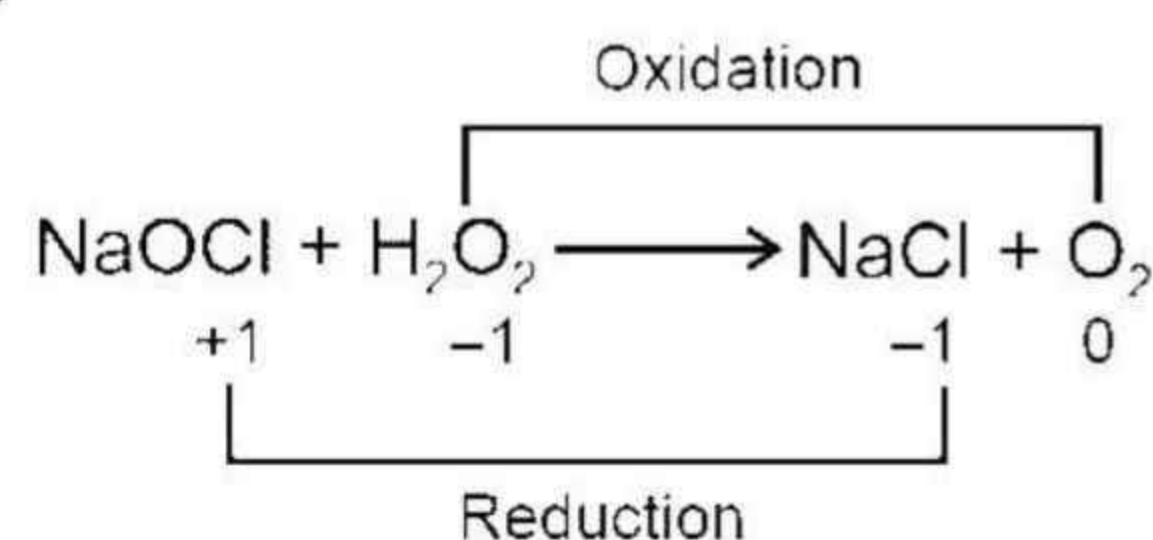

In Option (2), oxidation of H_2O_2 is taking place and hence H_2O_2 acts as a reducing agent.

14. Consider the following sequence of reaction :

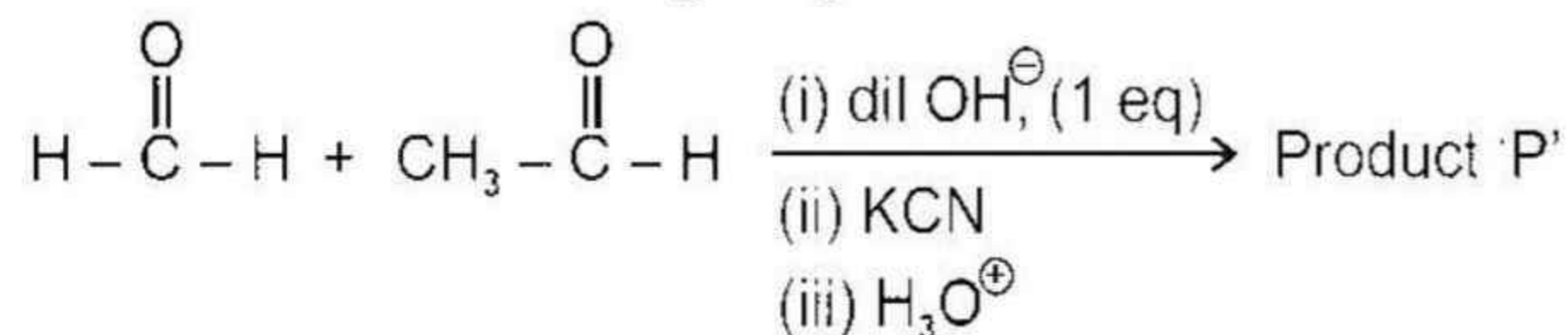

The product 'P' is?

- (1) $\text{CH}_3-\text{CH}_2-\text{COOH}$
(2) $\begin{array}{c} \text{OH} \quad \text{OH} \\ | \quad | \\ \text{CH}_2-\text{CH}_2-\text{CH}-\text{COOH} \end{array}$
(3) $\begin{array}{c} \text{OH} \quad \text{O} \\ | \quad \parallel \\ \text{CH}_2-\text{CH}_2-\text{C}-\text{COOH} \end{array}$
(4) $\begin{array}{c} \text{O} \quad \text{O} \\ \parallel \quad \parallel \\ \text{CH}-\text{CH}_2-\text{C}-\text{COOH} \end{array}$

Answer (2)

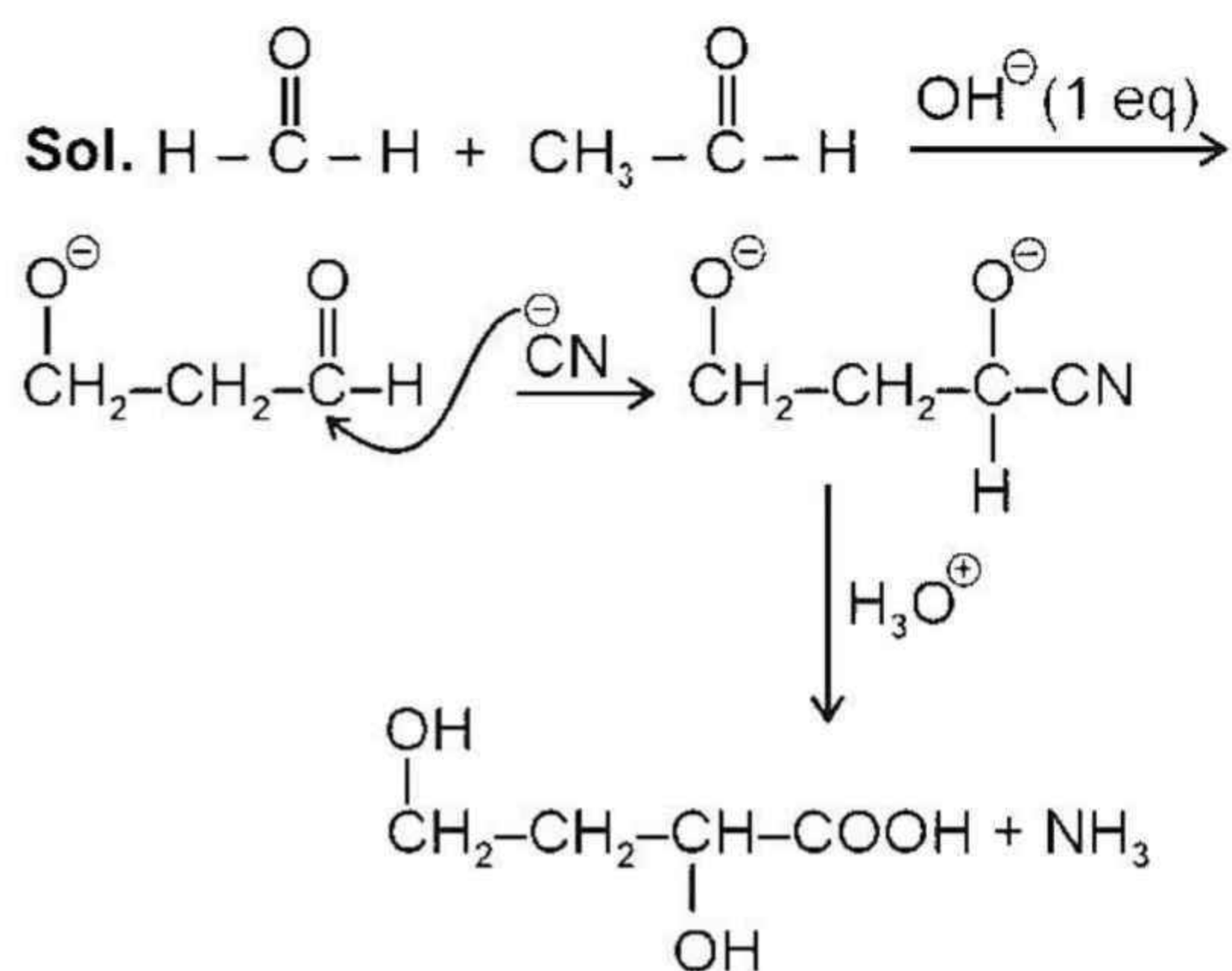

15. Which of the following transition emits the same wavelength as that for $(n = 4 \rightarrow n = 2)$ for He^+ ion

- (1) $\text{H}(n = 3 \rightarrow n = 1)$
(2) $\text{H}(n = 2 \rightarrow n = 1)$
(3) $\text{Li}^{2+}(n = 4 \rightarrow n = 3)$
(4) $\text{He}^+(n = 6 \rightarrow 3)$

Answer (2)

Sol. $\frac{\Delta E_{(\text{H-atom})}}{n = 2 \rightarrow n = 1} = \frac{(\Delta E)_{\text{He}^+ \text{ ion}}}{n = 4 \rightarrow n = 2} = \frac{(\Delta E)_{\text{Li}^{2+} \text{ ion}}}{n = 6 \rightarrow n = 3}$

16. A complex compound of Co (X) is pink colour in water. On reaction with conc. HCl forms (Y) of deep blue colour and has geometry (Z). Identify (X), (Y) and (Z).

- (1) $[\text{Co}(\text{H}_2\text{O})_6]^{2+}$, $[\text{CoCl}_6]^{3-}$, Octahedral
(2) $[\text{Co}(\text{H}_2\text{O})_6]^{3+}$, $[\text{CoCl}_4]^{2-}$, Tetrahedral
(3) $[\text{Co}(\text{H}_2\text{O})_6]^{2+}$, $[\text{CoCl}_4]^{2-}$, Tetrahedral
(4) $[\text{Co}(\text{H}_2\text{O})_6]^{3+}$, $[\text{CoCl}_6]^{3-}$, Octahedral

Answer (3)

Sol. Co^{2+} ions in aqueous medium are pink in colour. On addition of conc. HCl to it, the solution becomes blue due to formation of $[\text{CoCl}_4]^{2-}$ which is tetrahedral.

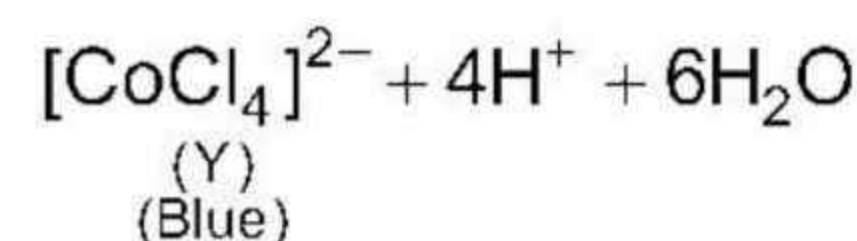
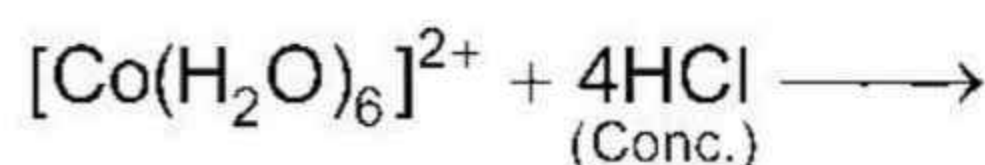
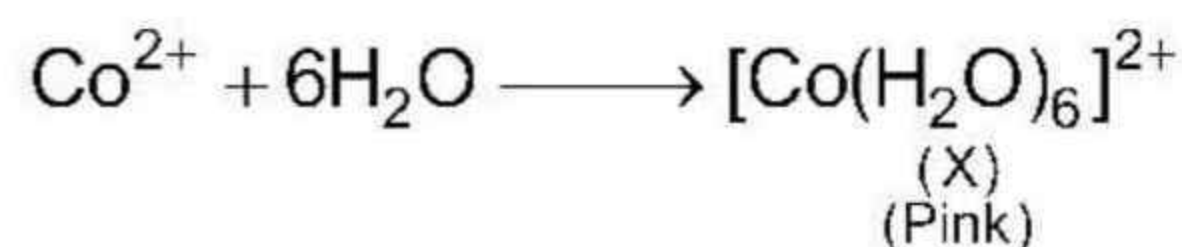

Geometry of (Y) is tetrahedral (Z).

17. Which of the following option contains the correct match?

- | List-I | List-II |
|----------------------------------|-------------------|
| (A) XeF ₄ | (P) T-shape |
| (B) SF ₄ | (Q) See-saw |
| (C) NH ₄ [⊕] | (R) Square planar |
| (D) BrF ₃ | (S) Tetrahedral |
- (1) A → P, B → Q, C → R, D → S
 (2) A → R, B → Q, C → S, D → P
 (3) A → Q, B → P, C → S, D → R
 (4) A → S, B → R, C → P, D → Q

Answer (2)

Sol. XeF₄ → Square planar

SF₄ → See-saw

NH₄[⊕] → Tetrahedral

BrF₃ → T-shaped

18. A detergent is dissolved in non-polar solvent. The structure of micelle in non-polar solvent

Detergent molecule

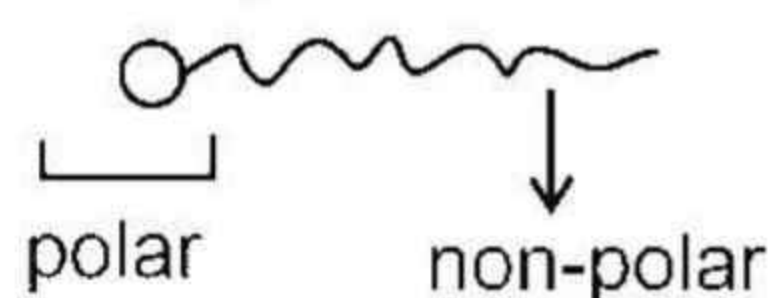

- (1)
- (2)
- (3)
- (4)

Answer (1)

Sol. In non-polar-solvent, non-polar part will be outside.

19. Consider the following reaction :



A, B and C are respectively

- (1) ClONO₂(g); HOCl(g); HNO₃(g)
 (2) ClONO₂(g); HOCl(g); NO₂(g)
 (3) ClNO₂(g); HCl; Cl₂
 (4) ClNO₂(g); HCl(g); HNO₃(g)

Answer (1)

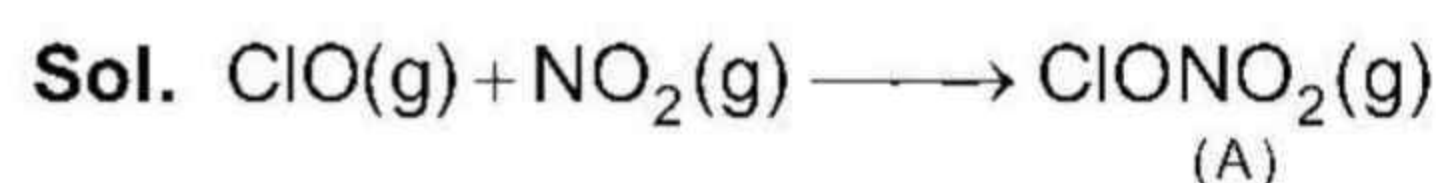

20.

SECTION - B

Numerical Value Type Questions: This section contains 10 questions. In Section B, attempt any five questions out of 10. The answer to each question is a **NUMERICAL VALUE**. For each question, enter the correct numerical value (in decimal notation, truncated/rounded-off to the second decimal place; e.g. 06.25, 07.00, -00.33, -00.30, 30.27, -27.30) using the mouse and the on-screen virtual numeric keypad in the place designated to enter the answer.

21. 2.56 g of a non-electrolyte solute is dissolved in one litre of a solution, it has osmotic pressure (π) equal to 4 bar at 300 K temperature. Then find the molar mass of the compound.

[Given : R = 0.083 bar] (Round off to the nearest integer)

Answer (16)

Sol. $p = CRT$

$$4 = \frac{2.56}{M} \times 0.083 \times 300$$

$$\approx 16 \text{ g}$$

22. Weight of an organic compounds is 0.492 g, when the hydrocarbon undergoes combustion it produces 0.792 g CO₂. Find the % of carbon in the given hydrocarbon (Round off to the nearest integer)

Answer (44)

$$\text{Sol. } \%C = \frac{12}{44} \times \frac{0.792}{0.492} \times 100$$

$$= 43.90\%$$

23. The oxidation state of phosphorus atom in the hypophosphoric acid is _____?

Answer (4)

Sol. The hypophosphoric acid is :

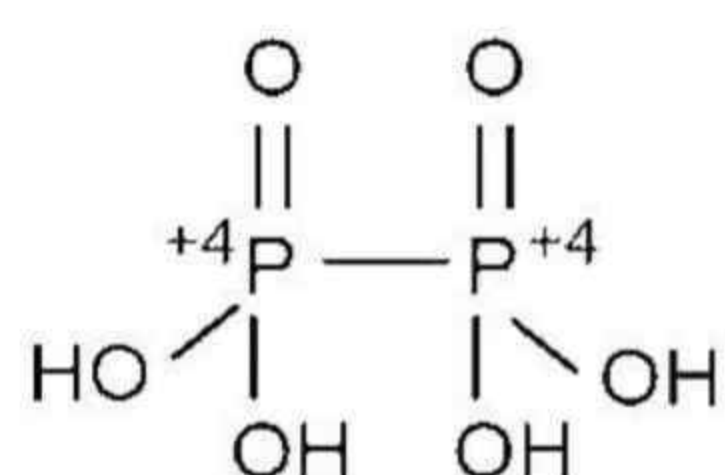

24. What is the volume of Hydrogen Gas produced (in litre) when 11.2 gm of Zn metal reacts with excess of dil. HCl (Closest Integer)

Given: Molar volume of H₂ = 22.7 L/mole

Molar mass of Zn is 65 gm/mole

Answer (4)



$$\left(\frac{11.2}{65} \right) \quad \frac{11.2}{65} \times 22.7 \text{ litre}$$

$$= 3.911 \text{ litre}$$

$$\approx 4 \text{ litre}$$

25. The value of logarithm of the equilibrium constant of the following reaction is $\frac{X}{3}$. Then 'X' is

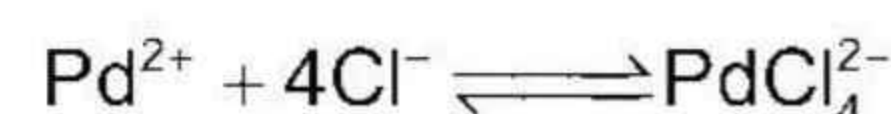

Given : $[\text{Pd}^{2+} + 2\text{e}^- \longrightarrow \text{Pd} \quad ; \quad E^\circ = 0.83 \text{ V}$

$\text{PdCl}_4^{2-} + 2\text{e}^- \longrightarrow \text{Pd} + 4\text{Cl}^- \quad ; \quad E^\circ = 0.63 \text{ V}$

and $\frac{2.303 RT}{F} = 0.06]$

Answer (20)

$$\text{Sol. } \Delta G_3^\circ = \Delta G_1^\circ - \Delta G_2^\circ$$

$$-2.303 \times RT \log k = -0.83 \times 2 \times F + 0.63 \times 2 \times F$$

$$\log k = \frac{0.2 \times 2 \times F}{2.303 \times RT}$$

$$= \frac{0.2 \times 2}{0.06} = \frac{20}{3}$$

26. Find the value of $|\Delta H|$ in kJ for

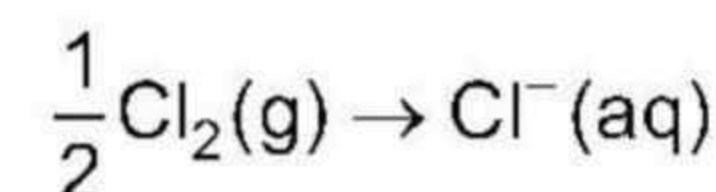

Given:

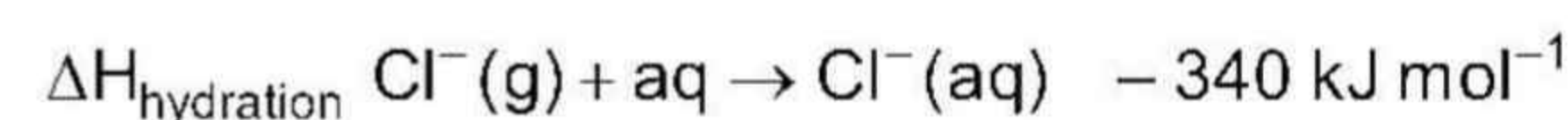
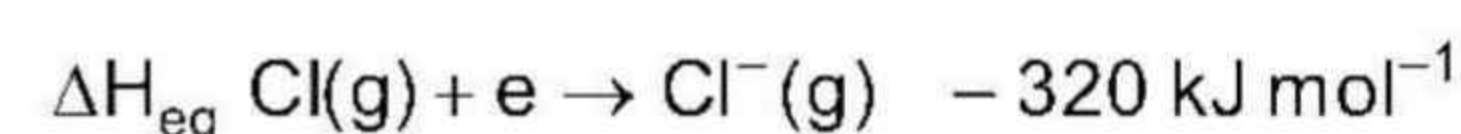

Answer (540)

Sol.

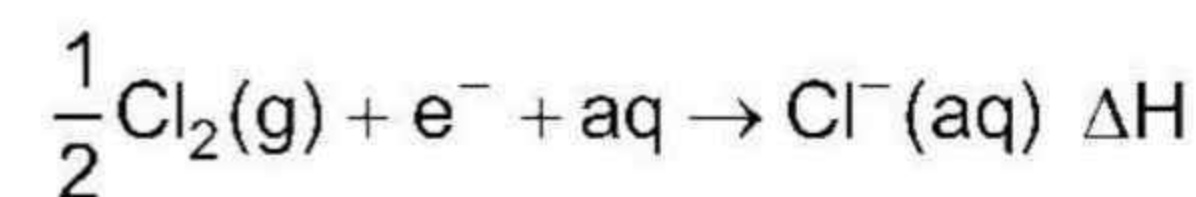
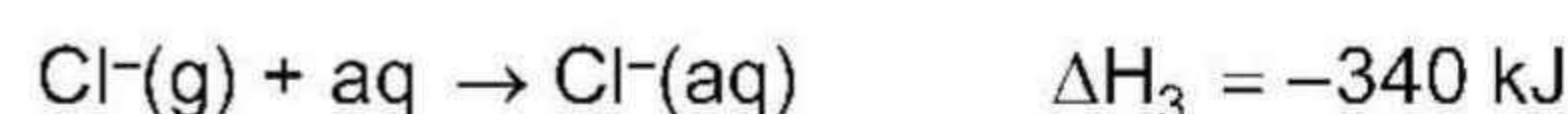

$$\Delta H = \Delta H_1 + \Delta H_2 + \Delta H_3$$

$$= 120 - 320 - 340$$

$$= -540 \text{ kJ}$$

$$|\Delta H| = 540 \text{ kJ}$$

$$D_{max} = 2 - b = 1 \Rightarrow b = 1$$

$$e^2 = 1 - \frac{1}{4}$$

$$e = \frac{\sqrt{3}}{2}$$

7. Let the curve C_1 be represented by $|z| = 2$ and C_2

$$\text{by } \left| z + \frac{1}{z} \right| = \frac{15}{4} \text{ then}$$

- (1) C_1 lies inside C_2
- (2) C_2 lies inside C_1
- (3) C_1 and C_2 has 2 points of intersection
- (4) C_1 and C_2 has 4 points of intersection

Answer (1)

Sol. Let $z = x + iy$

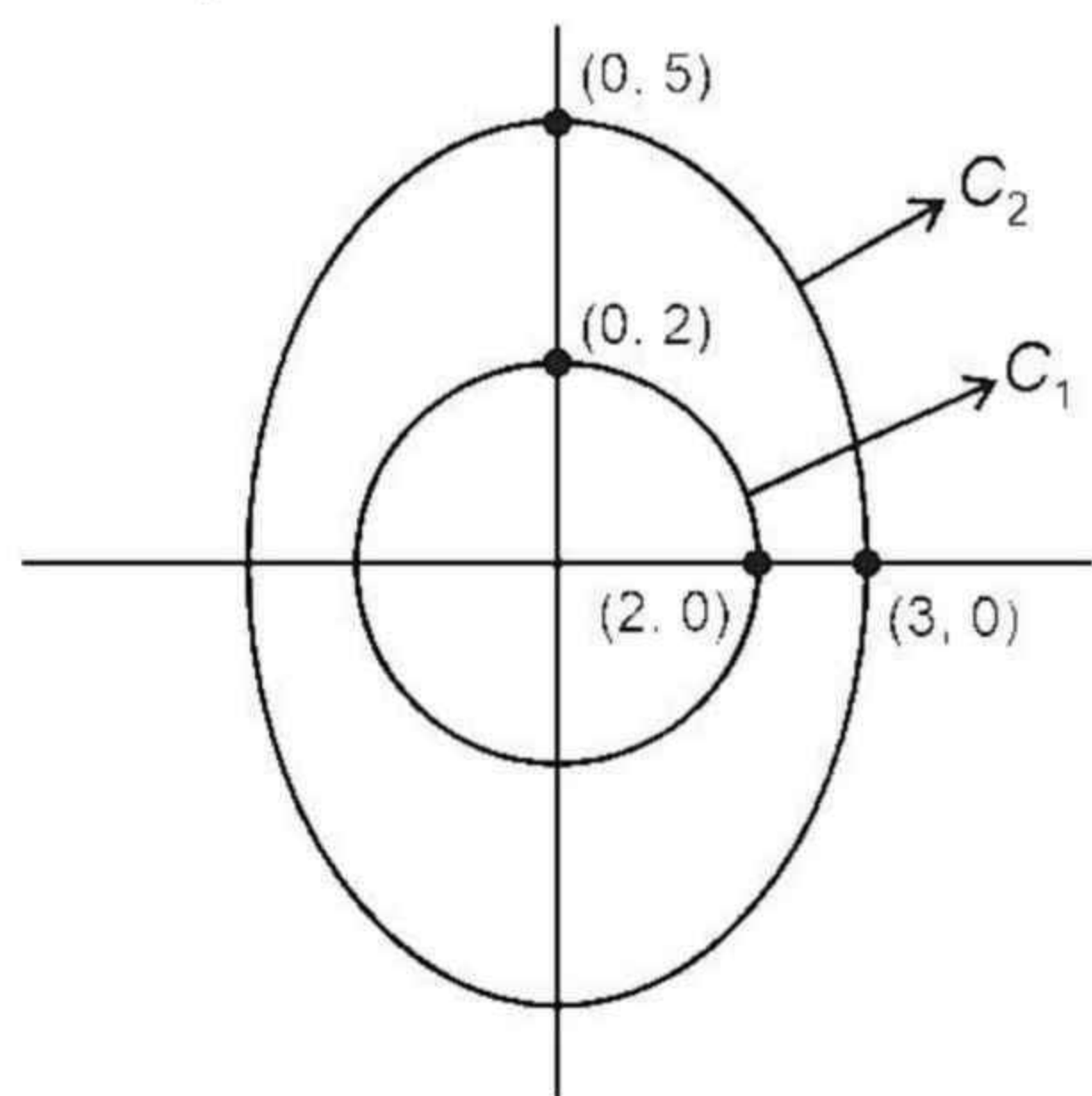

$$C_1 \Rightarrow x^2 + y^2 = 4$$

$$C_2 \Rightarrow \left| x + iy + \frac{1}{x + iy} \right| = \frac{15}{4}$$

$$\text{OR } \left| x + iy + \frac{x - iy}{4} \right| = \frac{15}{4}$$

$$\text{OR } \left(\frac{5x}{4} \right)^2 + \left(\frac{3y}{4} \right)^2 = \frac{225}{16}$$

$$\text{OR } \frac{x^2}{9} + \frac{y^2}{25} = 1$$

$$e = \sqrt{1 - \frac{1}{4}} = \frac{\sqrt{3}}{2}$$

8. Find the number of real solution(s) of

$$\sqrt{x^2 - 4x + 3} + \sqrt{x^2 - 9} = \sqrt{4x^2 - 14x + 6} \text{ is}$$

- (1) 1
- (2) 2
- (3) 3
- (4) 4

Answer (1)

Sol. $x^2 - 4x + 3 \geq 0$

$$(x - 1)(x - 3) \geq 0$$

$$x \in (-\infty, 1] \cup [3, \infty) \quad \dots(i)$$

$$x^2 - 9 \geq 0 \Rightarrow x \in (-\infty, -3] \cup [3, \infty) \quad \dots(ii)$$

$$4x^2 - 14x + 6 \geq 0 \Rightarrow (2x - 1)(x - 3) \geq 0$$

$$\Rightarrow x \in \left(-\infty, \frac{1}{2}\right] \cup [3, \infty) \quad \dots(iii)$$

$$(i) \cap (ii) \cap (iii)$$

$$x \in (-\infty, -3] \cup [3, \infty)$$

Now squaring both sides of given equation:

$$(x^2 - 4x + 3) + (x^2 - 9) + 2$$

$$\sqrt{(x^2 - 4x + 3)(x^2 - 9)} = 4x^2 - 14x + 6$$

$$\Rightarrow 2\sqrt{(x^2 - 4x + 3)(x - 3)(x + 3)} = 2(x^2 - 5x + 6)$$

$$\Rightarrow (x^2 - 4x + 3)(x - 3)(x + 3) = (x - 3)^2(x - 2)^2$$

$$x = 3 \text{ is one solution}$$

$$\Rightarrow (x^2 - 4x + 3)(x + 3) = (x^2 - 4x + 4)(x - 3)$$

$$\Rightarrow x^3 - 4x^2 + 3x + 3x^2 - 12x + 9 = x^3 - 4x^2 + 4x - 3x^2 + 12x - 12$$

$$\Rightarrow 6x^2 - 25x + 21 = 0$$

$$\Rightarrow x = 3, \frac{7}{6}$$

\therefore Only one real solution $x = 3$ as $x = \frac{7}{6}$, is not in the domain.

9. If $f(x) = \sin^3 \left(\frac{\pi}{3} \cos \left(\frac{\pi}{3\sqrt{2}} (-4x^3 + 5x^2 + 1)^{\frac{3}{2}} \right) \right)$ then

$f(1)$ is

$$(1) \frac{3\pi^2}{8} \quad (2) \frac{3\pi^2}{4}$$

$$(3) \frac{3\pi^2}{16} \quad (4) \frac{\pi^2}{2}$$

Answer (3)

$$\text{Sol. } f'(x) = 3 \sin^2 \left(\frac{\pi}{3} \cos \left(\frac{\pi}{3\sqrt{2}} (-4x^3 + 5x^2 + 1)^{\frac{3}{2}} \right) \right)$$

$$\cdot \cos \left(\frac{\pi}{3} \cos \left(\frac{\pi}{3\sqrt{2}} (-4x^3 + 5x^2 + 1)^{\frac{3}{2}} \right) \right)$$

$$\cdot \frac{\pi}{3} \left(-\sin \left(\frac{\pi}{3\sqrt{2}} (-4x^3 + 5x^2 + 1)^{\frac{3}{2}} \right) \right)$$

$$\begin{aligned} & \cdot \frac{\pi}{3\sqrt{2}} \cdot \frac{3}{2} (-4x^3 + 5x^2 + 1)^{\frac{1}{2}} \cdot (-12x^2 + 10x) \\ f'(1) &= 3 \sin^2 \left(\frac{\pi}{3} \cos \left(\frac{2\pi}{3} \right) \right) \cdot \cos \left(\frac{\pi}{3} \cos \left(\frac{2\pi}{3} \right) \right) \\ & \quad \cdot \frac{\pi}{3} \left(-\sin \frac{2\pi}{3} \right) \cdot \frac{\pi}{2\sqrt{2}} (\sqrt{2})(-2) \\ &= 3 \sin^2 \left(\frac{-\pi}{6} \right) \cdot \cos \left(\frac{-\pi}{6} \right) \cdot \frac{\pi}{3} \left(-\frac{\sqrt{3}}{2} \right) (-\pi) \\ &= \frac{3}{4} \cdot \frac{\sqrt{3}}{2} \cdot \frac{\pi}{3} \cdot \frac{\sqrt{3}}{2} \cdot \pi = \frac{3\pi^2}{16} \end{aligned}$$

10. Let \vec{a} , \vec{b} and \vec{c} be three non-zero vectors such that

$$|\vec{a} + \vec{b} + \vec{c}| = |\vec{a} + \vec{b} - \vec{c}| \text{ and } \vec{b} \cdot \vec{c} = 0 \text{ then}$$

Statement-I : $|\vec{a} + \lambda \vec{c}| \geq 0$ for all $\lambda \in \mathbf{R}$.

Statement-II : \vec{a} is always parallel to \vec{c} .

- (1) Statement-I is true, statement-II is false
- (2) Statement-I is true, statement-II is true
- (3) Statement-I is false, statement-II is true
- (4) Statement-I is false, statement-II is false

Answer (1)

Sol. $|\vec{a} + \vec{b} + \vec{c}|^2 = |\vec{a} + \vec{b} - \vec{c}|^2$

$$\Rightarrow \vec{a} \cdot \vec{b} + \vec{b} \cdot \vec{c} + \vec{c} \cdot \vec{a} = \vec{a} \cdot \vec{b} - \vec{b} \cdot \vec{c} - \vec{c} \cdot \vec{a}$$

$$\Rightarrow \vec{c} \cdot \vec{a} = 0$$

$\therefore \vec{a}$ is perpendicular to \vec{c}

$$|\vec{a} + \lambda \vec{c}| \geq 0 \quad (\text{However, it is always true})$$

and statement-II is false.

11. $A = \begin{bmatrix} 2 & 0 & 0 \\ 0 & 3 & 0 \\ 0 & 1 & 1 \end{bmatrix}$, then find sum of diagonal elements

of $(A - I)^{11}$

- (1) 4096
- (2) 4097
- (3) 2048
- (4) 2049

Answer (2)

Sol. $A - I = \begin{bmatrix} 1 & 0 & 0 \\ 0 & 2 & 0 \\ 0 & 0 & 0 \end{bmatrix}$

$$(A - I)^{11} = \begin{bmatrix} \underline{1^{11}} & & \\ & \underline{2^{11}} & \\ & & \underline{0^{11}} \end{bmatrix}$$

(Calculating only for diagonal elements)

$$\begin{aligned} \text{trace } (A - I)^{11} &= 2^{11} + 1^{11} \\ &= 4097 \end{aligned}$$

12. Circle $x^2 + y^2 - 4x - 6y + 11 = 0$ is rolled up by 4 units along a tangent to it at the point (3, 2).

Let this be circle C_1 , C_2 is the mirror image of circle C_1 about the tangent. A and B are centres of circles C_1 and C_2 . C and D are the feet of perpendicular from A and B respectively upon X -axis. The area of the trapezium $ABCD$ equals to

- (1) $4(1 + \sqrt{2})$
- (2) $2(1 + \sqrt{2})$
- (3) $3(1 + \sqrt{2})$
- (4) $1 + \sqrt{2}$

Answer (1)

Sol. Given circle is

$$x^2 + y^2 - 4x - 6y + 11 = 0, \text{ centre } E(2, 3)$$

Tangent at (3, 2) is

$$x - y - 1 = 0$$

After rolling up by 4 units,

Centre of C_1 is A

$$\text{Where } A = \left(2 + 4 \times \frac{1}{\sqrt{2}}, 3 + 4 \times \frac{1}{\sqrt{2}} \right)$$

$$= (2 + 2\sqrt{2}, 3 + 2\sqrt{2})$$

B is image of A

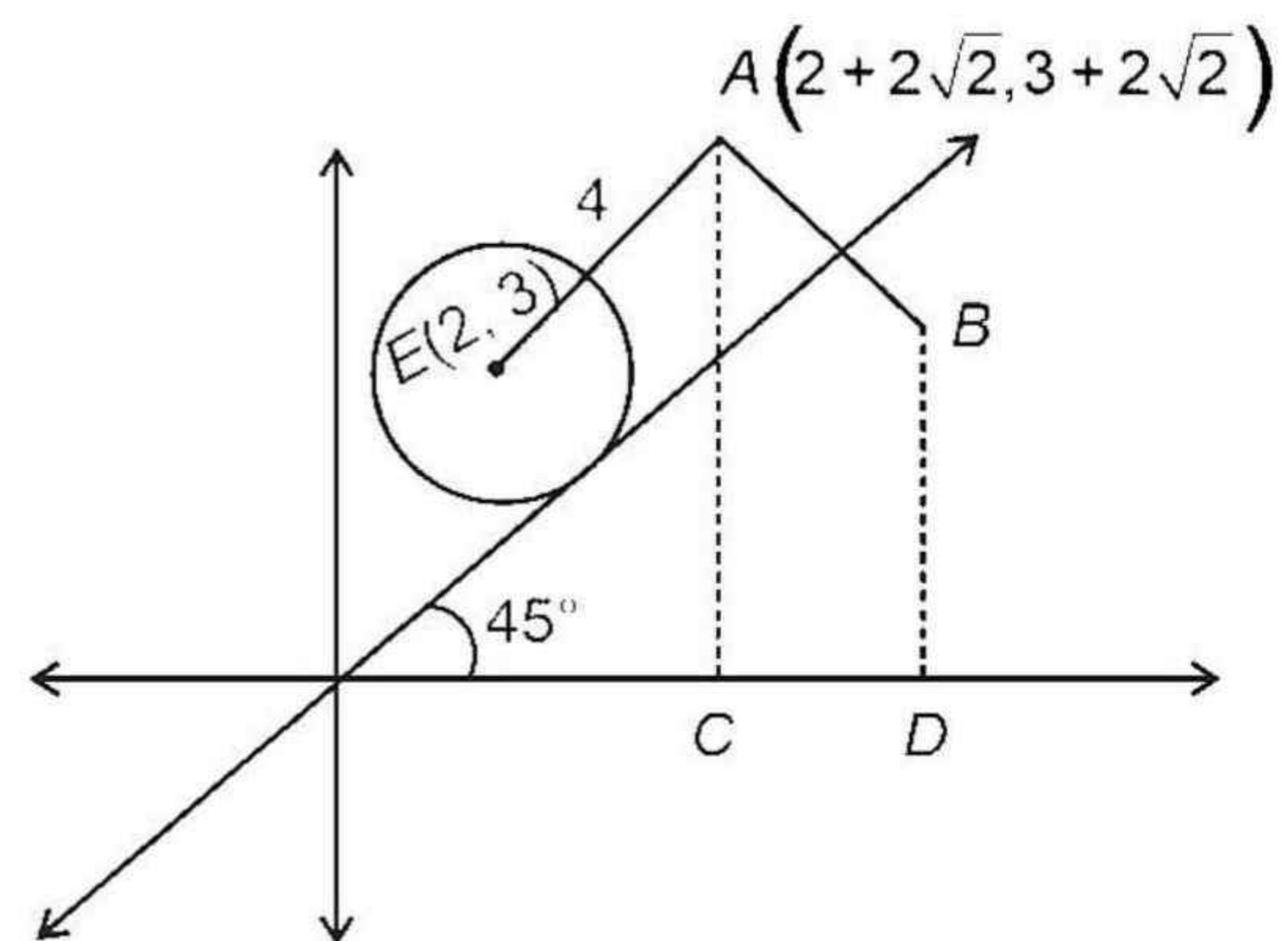

$$\frac{x - (2 + \sqrt{2})}{1} = \frac{y - (3 + 2\sqrt{2})}{-1} = -2 \left(\frac{-2}{2} \right) = 2$$

$$B(4 + 2\sqrt{2}, 1 + 2\sqrt{2})$$

Area of $ABCD$

$$\begin{aligned} &= \frac{1}{2} \times (4 + 4\sqrt{2}) \times ((4 + 2\sqrt{2}) - (2 + 2\sqrt{2})) \\ &= 4(1 + \sqrt{2}) \end{aligned}$$

13. Let the relation R , $(a, b) R (c, d)$ be such that $ab(d - c) = cd(a - b)$, then R is
- (1) Reflexive only
 - (2) Symmetric
 - (3) Transitive but not symmetric
 - (4) Reflexive and symmetric but not transitive

Answer (2)

Sol. Checking for reflexive

$$\therefore (a, b) R (a, b)$$

$$\Rightarrow ab(b - a) = ab(a - b)$$

$$1 = -1 \quad \therefore \text{Not reflexive}$$

Checking for $(a, b) R (c, d)$ then $(c, d) R (a, b)$

$$\Rightarrow cd(b - a) = ab(c - d)$$

$$\Rightarrow ab(d - c) = cd(a - b) \quad \therefore \text{Symmetric}$$

$$\therefore R \text{ is symmetric}$$

SECTION - B

Numerical Value Type Questions: This section contains 10 questions. In Section B, attempt any five questions out of 10. The answer to each question is a **NUMERICAL VALUE**. For each question, enter the correct numerical value (in decimal notation, truncated/rounded-off to the second decimal place; e.g. 06.25, 07.00, -00.33, -00.30, 30.27, -27.30) using the mouse and the on-screen virtual numeric keypad in the place designated to enter the answer.

21. Find the number of 5-digit numbers formed using the digits 0, 3, 4, 7, 9 when repetition of digits is allowed is

Answer (2500)

Sol.

$$4 \times 5 \times 5 \times 5 \times 5$$

$$\begin{aligned} \text{Total number of numbers} &= 4 \times 5 \times 5 \times 5 \times 5 \\ &= 2500 \end{aligned}$$

22. Find remainder when 5^{99} is divided by 11.

Answer (09)

$$\begin{aligned} \text{Sol. } 5^{99} &= (5^5)^{19} \cdot 5^4 \\ &= (3125)^{19} \cdot 5^4 \\ &= (11\lambda + 1)^{19} \cdot 5^4 \\ &= (11K + 1) 5^4 \\ &= 11K_1 + 5^4 \end{aligned}$$

When 5^4 is divided by 11, we get remainder = 9

23. If $f(x) + \int_3^x \frac{f(t)}{t} dt = \sqrt{x+1}$ then value of $12f(8)$ equals.

Answer (17)

Sol. Differentiating both sides we get

$$f'(x) + \frac{f(x)}{x} = \frac{1}{2\sqrt{x+1}}$$

$$\Rightarrow \frac{dy}{dx} + \frac{y}{x} = \frac{1}{2\sqrt{x+1}}$$

$$\text{I.F.} = e^{\int \frac{1}{x} dx} = x$$

$$\therefore xy = \frac{1}{2} \int \frac{x}{\sqrt{x+1}} dx$$

$$\Rightarrow xy = \frac{1}{2} \int \left(\sqrt{x+1} - \frac{1}{\sqrt{x+1}} \right) dx$$

$$\Rightarrow xy = \frac{1}{2} \left(\frac{2}{3} (x+1)^{3/2} - 2\sqrt{x+1} \right) + c$$

$$\text{Put } x = 3 \text{ in } f(x) + \int_3^x \frac{f(t)}{t} dt = \sqrt{x+1} \text{ we get } f(3) = 2$$

$$\therefore c = \frac{16}{3}$$

$$\Rightarrow 8f(8) = \frac{1}{2} \left(\frac{27}{3} \cdot 2 - 2 \cdot 3 \right) + \frac{16}{3}$$

$$\Rightarrow 12f(8) = 17$$

24. $y = f(x)$ is a parabola with focus $\left(-\frac{1}{2}, 0\right)$ and directrix $y = -\frac{1}{2}$

$$\text{Given that } \tan^{-1} \sqrt{f(x)} + \sin^{-1} \sqrt{f(x)+1} = \frac{\pi}{2}$$

Then number of solutions for x is

Answer (02)

Sol. $SP = SQ$

$$\left(x + \frac{1}{2}\right)^2 + y^2 = \left(y + \frac{1}{2}\right)^2$$

$$x^2 + \frac{1}{4} + x + y^2 = y^2 + \frac{1}{4} + y$$

\Rightarrow Eqn. of parabola $y = x^2 + x$

$$f(x) = x^2 + x$$

$$\tan^{-1} \sqrt{x^2 + x} + \sin^{-1} \sqrt{x^2 + x + 1} = \frac{\pi}{2}$$

$$\tan^{-1} \sqrt{x^2 + x} = \cos^{-1} \sqrt{x^2 + x + 1}$$

$$\cos^{-1} \frac{1}{\sqrt{x^2 + x + 1}} = \cos^{-1} \sqrt{x^2 + x + 1}$$

$$\Rightarrow \frac{1}{\sqrt{x^2 + x + 1}} = \sqrt{x^2 + x + 1}$$

$$\Rightarrow x^2 + x + 1 = 1$$

Or $x = 0, -1$

25. The direction ratio's of two lines which are parallel are given by $\langle 2, 1, -1 \rangle$ and $\langle \alpha + \beta, 1 + \beta, 2 \rangle$. Find $|2\alpha + 3\beta|$

Answer (11)

$$\text{Sol. } \frac{\alpha + \beta}{2} = \frac{1 + \beta}{1} = \frac{2}{-1}$$

$$\Rightarrow \alpha + \beta = -4, 1 + \beta = -2$$

$$\text{So, } \beta = -3, \alpha = -1$$

$$|2\alpha + 3\beta| = 11$$

26. Given $|\dot{a}| = \sqrt{14}, |\dot{b}| = \sqrt{6}, |\dot{a} \times \dot{b}| = \sqrt{48}$. Find $(\dot{a} \cdot \dot{b})^2$

Answer (36.00)

$$\begin{aligned} \text{Sol. } (\dot{a} \cdot \dot{b})^2 &= |\dot{a}|^2 |\dot{b}|^2 - (\dot{a} \times \dot{b})^2 \\ &= 14 \cdot 6 - 48 \\ &= 36 \end{aligned}$$