

National Testing Agency

Question Paper Name:	Paper I EH 9th Jan 2019 Shift 2
Subject Name:	Paper I EH
Creation Date:	2019-01-09 20:44:40
Duration:	180
Total Marks:	360
Display Marks:	Yes
Share Answer Key With Delivery Engine:	Yes
Actual Answer Key:	Yes

Paper I

Group Number :	1
Group Id :	416529111
Group Maximum Duration :	0
Group Minimum Duration :	180
Revisit allowed for view? :	No
Revisit allowed for edit? :	No
Break time:	0
Group Marks:	360

Physics

Section Id :	416529115
Section Number :	1
Section type :	Online
Mandatory or Optional:	Mandatory
Number of Questions:	30
Number of Questions to be attempted:	30
Section Marks:	120
Display Number Panel:	Yes
Group All Questions:	No

Sub-Section Number:	1
Sub-Section Id:	416529124
Question Shuffling Allowed :	Yes

Question Number : 1 Question Id : 4165298786 Question Type : MCQ Option Shuffling : Yes Display Question Number : Yes
Single Line Question Option : No Option Orientation : Vertical

Correct Marks : 4 Wrong Marks : 1

Expression for time in terms of G (universal gravitational constant), h (Planck constant) and c (speed of light) is proportional to :

Options :

41652934602.

$$\sqrt{\frac{Gh}{c^3}}$$

41652934603.

$$\sqrt{\frac{c^3}{Gh}}$$

41652934604.

$$\sqrt{\frac{Gh}{c^5}}$$

41652934605.

$$\sqrt{\frac{hc^5}{G}}$$

Question Number : 1 Question Id : 4165298786 Question Type : MCQ Option Shuffling : Yes Display Question Number : Yes
Single Line Question Option : No Option Orientation : Vertical

Correct Marks : 4 Wrong Marks : 1

G (सार्वत्रिक गुरुत्वाकर्षण नियतांक), h (प्लांक नियतांक) तथा c (प्रकाश की गति) के रूप में समय का समतुल्य संबंध निम्न में किसके समानुपाती होगा ?

Options :

41652934602.

$$\sqrt{\frac{Gh}{c^3}}$$

41652934603.

$$\sqrt{\frac{c^3}{Gh}}$$

41652934604.

$$\sqrt{\frac{Gh}{c^5}}$$

41652934605.

$$\sqrt{\frac{hc^5}{G}}$$

Question Number : 2 Question Id : 4165298787 Question Type : MCQ Option Shuffling : Yes Display Question Number : Yes
Single Line Question Option : No Option Orientation : Vertical

Correct Marks : 4 Wrong Marks : 1

In a car race on straight road, car A takes a time t less than car B at the finish and passes finishing point with a speed ' v ' more than that of car B. Both the cars start from rest and travel with constant acceleration a_1 and a_2 respectively. Then ' v ' is equal to :

Options :

41652934606. $\sqrt{2a_1a_2} t$

41652934607. $\sqrt{a_1a_2} t$

41652934608. $\frac{a_1 + a_2}{2} t$

41652934609. $\frac{2a_1a_2}{a_1 + a_2} t$

Question Number : 2 Question Id : 4165298787 Question Type : MCQ Option Shuffling : Yes Display Question Number : Yes
Single Line Question Option : No Option Orientation : Vertical

Correct Marks : 4 Wrong Marks : 1

एक सीधी सड़क पर कारों की एक स्पर्धा में, कार 'A' को कार 'B' की अपेक्षा अंत तक पहुँचने में 't' समय कम लगता है तथा अन्त बिन्दु पर उसकी गति कार 'B' से v अधिक होती है। दोनों कारें स्थिरावस्था से नियत त्वरण a_1 तथा a_2 से चलती हैं। v का मान होगा :

Options :

41652934606. $\sqrt{2a_1a_2} t$

41652934607. $\sqrt{a_1a_2} t$

41652934608. $\frac{a_1 + a_2}{2} t$

41652934609. $\frac{2a_1a_2}{a_1 + a_2} t$

Question Number : 3 Question Id : 4165298788 Question Type : MCQ Option Shuffling : Yes Display Question Number : Yes
Single Line Question Option : No Option Orientation : Vertical

Correct Marks : 4 Wrong Marks : 1

The position co-ordinates of a particle moving in a 3-D coordinate system is given

by $x = a \cos \omega t$

$y = a \sin \omega t$

and $z = a \omega t$

The speed of the particle is :

Options :

$$a\omega$$

41652934610.

$$2a\omega$$

41652934611.

$$\sqrt{2} a\omega$$

41652934612.

$$\sqrt{3} a\omega$$

41652934613.

Question Number : 3 Question Id : 4165298788 Question Type : MCQ Option Shuffling : Yes Display Question Number : Yes
Single Line Question Option : No Option Orientation : Vertical

Correct Marks : 4 Wrong Marks : 1

एक त्रिविमीय निर्देशांक निकाय में गतिशील एक कण के स्थिति निर्देशांक निम्न हैं :

$$x = a \cos \omega t$$

$$y = a \sin \omega t$$

$$z = a\omega t$$

इस कण की गति का मान होगा :

Options :

$$a\omega$$

41652934610.

$$2a\omega$$

41652934611.

$$\sqrt{2} a\omega$$

41652934612.

$$\sqrt{3} a\omega$$

41652934613.

Question Number : 4 Question Id : 4165298789 Question Type : MCQ Option Shuffling : Yes Display Question Number : Yes
Single Line Question Option : No Option Orientation : Vertical

Correct Marks : 4 Wrong Marks : 1

A mass of 10 kg is suspended vertically by a rope from the roof. When a horizontal force is applied on the rope at some point, the rope deviated at an angle of 45° at the roof point. If the suspended mass is at equilibrium, the magnitude of the force applied is ($g = 10 \text{ ms}^{-2}$)

Options :

$$100 \text{ N}$$

41652934614.

$$200 \text{ N}$$

41652934615.

41652934616. 140 N

41652934617. 70 N

Question Number : 4 Question Id : 4165298789 Question Type : MCQ Option Shuffling : Yes Display Question Number : Yes
Single Line Question Option : No Option Orientation : Vertical

Correct Marks : 4 Wrong Marks : 1

छत से 10 kg के एक द्रव्यमान को एक रस्सी से ऊर्ध्वाधर लटकाया गया है। रस्सी के किसी बिन्दु पर एक क्षैतिज बल लगाने से रस्सी छत वाले बिन्दु पर 45° कोण से विचलित हो जाती है। यदि लटका हुआ द्रव्यमान साम्यावस्था में है तो लगाये गये बल का मान होगा : (दिया है : $g = 10 \text{ ms}^{-2}$)

Options :

41652934614. 100 N

41652934615. 200 N

41652934616. 140 N

41652934617. 70 N

Question Number : 5 Question Id : 4165298790 Question Type : MCQ Option Shuffling : Yes Display Question Number : Yes
Single Line Question Option : No Option Orientation : Vertical

Correct Marks : 4 Wrong Marks : 1

A force acts on a 2 kg object so that its position is given as a function of time as $x = 3t^2 + 5$. What is the work done by this force in first 5 seconds ?

Options :

41652934618. 950 J

41652934619. 900 J

41652934620. 875 J

41652934621. 850 J

Question Number : 5 Question Id : 4165298790 Question Type : MCQ Option Shuffling : Yes Display Question Number : Yes
Single Line Question Option : No Option Orientation : Vertical

Correct Marks : 4 Wrong Marks : 1

2 kg द्रव्यमान के एक पिण्ड पर एक बल लगाते हैं जिससे उसकी स्थिति का समय के साथ परिवर्तन $x = 3t^2 + 5$ है। इस बल द्वारा प्रथम 5 s में किया गया कार्य होगा :

Options :

41652934618. 950 J

41652934619. 900 J

41652934620. 875 J

41652934621. 850 J

Question Number : 6 Question Id : 4165298791 Question Type : MCQ Option Shuffling : Yes Display Question Number : Yes Single Line Question Option : No Option Orientation : Vertical

Correct Marks : 4 Wrong Marks : 1

A rod of length 50 cm is pivoted at one end. It is raised such that it makes an angle of 30° from the horizontal as shown and released from rest. Its angular speed when it passes through the horizontal (in rad s^{-1}) will be ($g = 10 \text{ ms}^{-2}$)

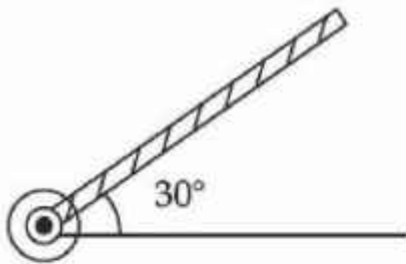

Options :

41652934622. $\sqrt{30}$

41652934623. $\sqrt{\frac{30}{2}}$

41652934624. $\frac{\sqrt{30}}{2}$

41652934625. $\frac{\sqrt{20}}{3}$

Question Number : 6 Question Id : 4165298791 Question Type : MCQ Option Shuffling : Yes Display Question Number : Yes Single Line Question Option : No Option Orientation : Vertical

Correct Marks : 4 Wrong Marks : 1

50 cm की एक छड़ के एक सिरे को कीलकित किया है। इसको क्षैतिज से 30° कोण पर, चित्रानुसार, उठाकर स्थिरावस्था से छोड़ दिया जाता है। जब यह छड़ क्षैतिज अवस्था से गुजरती है तो इसकी कोणीय चाल का rad s^{-1} में मान होगा : (दिया है : $g = 10 \text{ ms}^{-2}$)

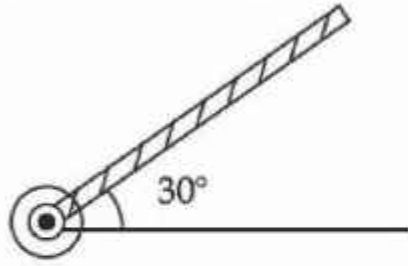

Options :

41652934622. $\sqrt{30}$

41652934623. $\sqrt{\frac{30}{2}}$

41652934624. $\frac{\sqrt{30}}{2}$

41652934625. $\frac{\sqrt{20}}{3}$

Question Number : 7 Question Id : 4165298792 Question Type : MCQ Option Shuffling : Yes Display Question Number : Yes
Single Line Question Option : No Option Orientation : Vertical

Correct Marks : 4 Wrong Marks : 1

A rod of mass 'M' and length '2L' is suspended at its middle by a wire. It exhibits torsional oscillations; If two masses each of 'm' are attached at distance 'L/2' from its centre on both sides, it reduces the oscillation frequency by 20%. The value of ratio m/M is close to :

Options :

41652934626. 0.17

41652934627. 0.77

41652934628. 0.57

41652934629. 0.37

Question Number : 7 Question Id : 4165298792 Question Type : MCQ Option Shuffling : Yes Display Question Number : Yes
Single Line Question Option : No Option Orientation : Vertical

Correct Marks : 4 Wrong Marks : 1

द्रव्यमान 'M' तथा लम्बाई '2L' की एक छड़ को उसके मध्यबिन्दु से एक तार द्वारा लटकाया गया है। यह छड़ मरोड़ दोलन करती है। यदि प्रत्येक द्रव्यमान 'm' के दो पिण्डों को छड़ के मध्यबिन्दु से 'L/2' दूरी पर दोनों तरफ जोड़ते हैं, तो दोलन की आवृत्ति 20% घट जाती है। अनुपात m/M का सन्निकट मान होगा :

Options :

41652934626. 0.17

41652934627. 0.77

41652934628. 0.57

41652934629. 0.37

Question Number : 8 Question Id : 4165298793 Question Type : MCQ Option Shuffling : Yes Display Question Number : Yes
Single Line Question Option : No Option Orientation : Vertical

Correct Marks : 4 Wrong Marks : 1

The energy required to take a satellite to a height 'h' above Earth surface (radius of Earth = 6.4×10^3 km) is E_1 and kinetic energy required for the satellite to be in a circular orbit at this height is E_2 . The value of h for which E_1 and E_2 are equal, is :

Options :

41652934630. 1.28×10^4 km

41652934631. 6.4×10^3 km

41652934632. 1.6×10^3 km

41652934633. 3.2×10^3 km

Question Number : 8 Question Id : 4165298793 Question Type : MCQ Option Shuffling : Yes Display Question Number : Yes
Single Line Question Option : No Option Orientation : Vertical

Correct Marks : 4 Wrong Marks : 1

एक उपग्रह को पृथ्वी की सतह से ऊँचाई h तक लाने में E_1 ऊर्जा लगती है तथा इस उपग्रह को इस ऊँचाई की वृत्ताकार कक्षा में रखने के लिए E_2 ऊर्जा की आवश्यकता होती है। h का वह मान, जिसके लिए E_1 तथा E_2 बराबर हैं, होगा :

(दिया है : पृथ्वी की त्रिज्या = 6.4×10^3 km)

Options :

41652934630. 1.28×10^4 km

41652934631. 6.4×10^3 km

41652934632. 1.6×10^3 km

41652934633. 3.2×10^3 km

Question Number : 9 Question Id : 4165298794 Question Type : MCQ Option Shuffling : Yes Display Question Number : Yes
Single Line Question Option : No Option Orientation : Vertical

Correct Marks : 4 Wrong Marks : 1

The top of a water tank is open to air and its water level is maintained. It is giving out 0.74 m^3 water per minute through a circular opening of 2 cm radius in its wall. The depth of the centre of the opening from the level of water in the tank is close to :

Options :

41652934634. 4.8 m

41652934635. 9.6 m

41652934636. 2.9 m

41652934637. 6.0 m

Question Number : 9 Question Id : 4165298794 Question Type : MCQ Option Shuffling : Yes Display Question Number : Yes
Single Line Question Option : No Option Orientation : Vertical

Correct Marks : 4 Wrong Marks : 1

पानी की एक टंकी ऊपर से खुली हुयी है तथा इसमें पानी का स्तर स्थिर है। इसकी दीवार में उपस्थित एक 2 cm त्रिज्या के वृत्ताकार छेद से पानी $0.74 \text{ m}^3/\text{min}$. की दर से बह रहा है। इस छेद के केन्द्र की पानी की सतह से गहराई का सन्निकट मान होगा :

Options :

41652934634. 4.8 m

41652934635. 9.6 m

41652934636. 2.9 m

41652934637. 6.0 m

Question Number : 10 Question Id : 4165298795 Question Type : MCQ Option Shuffling : Yes Display Question Number : Yes
Single Line Question Option : No Option Orientation : Vertical

Correct Marks : 4 Wrong Marks : 1

Two Carnot engines A and B are operated in series. The first one, A, receives heat at $T_1 (= 600 \text{ K})$ and rejects to a reservoir at temperature T_2 . The second engine B receives heat rejected by the first engine and, in turn, rejects to a heat reservoir at $T_3 (= 400 \text{ K})$. Calculate the temperature T_2 if the work outputs of the two engines are equal :

Options :

41652934638. 300 K

41652934639. 400 K

41652934640. 500 K

41652934641. 600 K

Question Number : 10 Question Id : 4165298795 Question Type : MCQ Option Shuffling : Yes Display Question Number : Yes
Single Line Question Option : No Option Orientation : Vertical

Correct Marks : 4 Wrong Marks : 1

दो कार्नों (Carnot) इंजन A तथा B को श्रेणीक्रम में चलाया जाता है। पहला इंजन A तापमान $T_1 (= 600 \text{ K})$ पर ऊष्मा लेता है व तापमान T_2 के एक ऊष्मा भंडार को ऊष्मा देता है। दूसरा इंजन B इस पहले इंजन द्वारा दी हुयी ऊष्मा को लेकर तापमान $T_3 (= 400 \text{ K})$ के ऊष्मा भंडार को ऊष्मा देता है। यदि दोनों इंजनों का कार्य उत्पादन बराबर है तो T_2 का मान होगा :

Options :

41652934638. 300 K

41652934639. 400 K

41652934640. 500 K

41652934641. 600 K

Question Number : 11 Question Id : 4165298796 Question Type : MCQ Option Shuffling : Yes Display Question Number : Yes
Single Line Question Option : No Option Orientation : Vertical

Correct Marks : 4 Wrong Marks : 1

A 15 g mass of nitrogen gas is enclosed in a vessel at a temperature 27°C . Amount of heat transferred to the gas, so that rms velocity of molecules is doubled, is about :

[Take $R = 8.3 \text{ J/K mole}$]

Options :

41652934642. 0.9 kJ

41652934643. 6 kJ

41652934644. 10 kJ

41652934645. 14 kJ

Question Number : 11 Question Id : 4165298796 Question Type : MCQ Option Shuffling : Yes Display Question Number : Yes
Single Line Question Option : No Option Orientation : Vertical

Correct Marks : 4 Wrong Marks : 1

नाइट्रोजन गैस की 15 g मात्रा को एक पात्र में 27°C पर रखा है। ऊष्मा की वह मात्रा, जिससे गैस के अणुओं का वर्ग माध्य मूल वेग दो गुना हो जायेगा, का मान होगा : (दिया है : $R = 8.3 \text{ J/K mole}$)

Options :

41652934642. 0.9 kJ

41652934643. 6 kJ

41652934644. 10 kJ

41652934645. 14 kJ

Question Number : 12 Question Id : 4165298797 Question Type : MCQ Option Shuffling : Yes Display Question Number : Yes
Single Line Question Option : No Option Orientation : Vertical

Correct Marks : 4 Wrong Marks : 1

A musician using an open flute of length 50 cm produces second harmonic sound waves. A person runs towards the musician from another end of a hall at a speed of 10 km/h. If the wave speed is 330 m/s, the frequency heard by the running person shall be close to :

Options :

41652934646. 333 Hz

41652934647. 500 Hz

41652934648. 666 Hz

41652934649. 753 Hz

Question Number : 12 Question Id : 4165298797 Question Type : MCQ Option Shuffling : Yes Display Question Number : Yes
Single Line Question Option : No Option Orientation : Vertical

Correct Marks : 4 Wrong Marks : 1

50 cm लम्बाई की खुले सिरे की एक बाँसुरी से एक संगीतज्ञ द्वितीय सत्रादी ध्वनि तरंगें उत्पन्न करता है। एक व्यक्ति कक्ष के दूसरे सिरे से संगीतज्ञ की तरफ 10 km/h की गति से दौड़ता है। यदि ध्वनि की गति 330 m/s है तो दौड़ते हुये व्यक्ति द्वारा सुनी गयी आवृत्ति का सन्निकट मान होगा :

Options :

41652934646. 333 Hz

41652934647. 500 Hz

41652934648. 666 Hz

41652934649. 753 Hz

Question Number : 13 Question Id : 4165298798 Question Type : MCQ Option Shuffling : Yes Display Question Number : Yes
Single Line Question Option : No Option Orientation : Vertical

Correct Marks : 4 Wrong Marks : 1

A particle is executing simple harmonic motion (SHM) of amplitude A , along the x -axis, about $x=0$. When its potential Energy (PE) equals kinetic energy (KE), the position of the particle will be :

Options :

41652934650. A

41652934651. $\frac{A}{2}$

41652934652. $\frac{A}{\sqrt{2}}$

41652934653. $\frac{A}{2\sqrt{2}}$

Question Number : 13 Question Id : 4165298798 Question Type : MCQ Option Shuffling : Yes Display Question Number : Yes
Single Line Question Option : No Option Orientation : Vertical

Correct Marks : 4 Wrong Marks : 1

एक कण x -अक्ष की दिशा में, $x=0$ के सापेक्ष आयाम A से सरल आवर्त गति कर रहा है। जब इस कण की स्थितिज ऊर्जा तथा गतिज ऊर्जा के मान बराबर हैं, तो कण की स्थिति होगी :

Options :

41652934650. A

41652934651. $\frac{A}{2}$

41652934652. $\frac{A}{\sqrt{2}}$

41652934653. $\frac{A}{2\sqrt{2}}$

Question Number : 14 Question Id : 4165298799 Question Type : MCQ Option Shuffling : Yes Display Question Number : Yes
Single Line Question Option : No Option Orientation : Vertical

Correct Marks : 4 Wrong Marks : 1

A parallel plate capacitor with square plates is filled with four dielectrics of dielectric constants K_1, K_2, K_3, K_4 arranged as shown in the figure. The effective dielectric constant K will be :

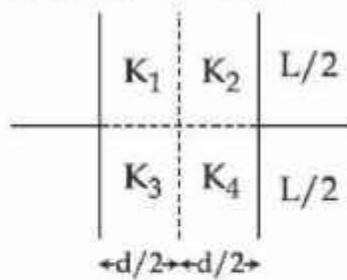

Options :

41652934654. $K = \frac{(K_1 + K_2)(K_3 + K_4)}{K_1 + K_2 + K_3 + K_4}$

41652934655. $K = \frac{(K_1 + K_3)(K_2 + K_4)}{K_1 + K_2 + K_3 + K_4}$

41652934656. $K = \frac{(K_1 + K_4)(K_2 + K_3)}{2(K_1 + K_2 + K_3 + K_4)}$

$$K = \frac{(K_1 + K_2)(K_3 + K_4)}{2(K_1 + K_2 + K_3 + K_4)}$$

41652934657.

Question Number : 14 Question Id : 4165298799 Question Type : MCQ Option Shuffling : Yes Display Question Number : Yes
Single Line Question Option : No Option Orientation : Vertical

Correct Marks : 4 Wrong Marks : 1

वर्गाकार प्लेटों वाले एक समान्तर प्लेट संधारित्र को चित्रानुसार चार परावैद्युतों, जिनके परावैद्युतांक K_1, K_2, K_3 तथा K_4 हैं, से भर दिया जाता है तो प्रभावी परावैद्युतांक K का मान होगा :

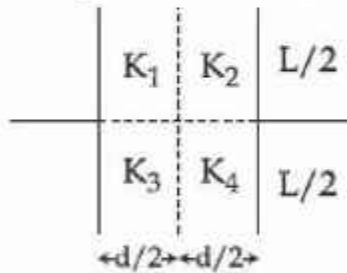

Options :

$$K = \frac{(K_1 + K_2)(K_3 + K_4)}{K_1 + K_2 + K_3 + K_4}$$

41652934654.

$$K = \frac{(K_1 + K_3)(K_2 + K_4)}{K_1 + K_2 + K_3 + K_4}$$

41652934655.

$$K = \frac{(K_1 + K_4)(K_2 + K_3)}{2(K_1 + K_2 + K_3 + K_4)}$$

41652934656.

$$K = \frac{(K_1 + K_2)(K_3 + K_4)}{2(K_1 + K_2 + K_3 + K_4)}$$

41652934657.

Question Number : 15 Question Id : 4165298800 Question Type : MCQ Option Shuffling : Yes Display Question Number : Yes
Single Line Question Option : No Option Orientation : Vertical

Correct Marks : 4 Wrong Marks : 1

Charge is distributed within a sphere of radius R with a volume charge density

$$\rho(r) = \frac{A}{r^2} e^{-2r/a}, \text{ where } A \text{ and } a \text{ are constants.}$$

If Q is the total charge of this charge distribution, the radius R is :

Options :

$$\frac{a}{2} \log \left(1 - \frac{Q}{2\pi a A} \right)$$

41652934658.

$$\frac{a}{2} \log \left(\frac{1}{1 - \frac{Q}{2\pi aA}} \right)$$

41652934659.

$$a \log \left(1 - \frac{Q}{2\pi aA} \right)$$

41652934660.

$$a \log \left(\frac{1}{1 - \frac{Q}{2\pi aA}} \right)$$

41652934661.

Question Number : 15 Question Id : 4165298800 Question Type : MCQ Option Shuffling : Yes Display Question Number : Yes
Single Line Question Option : No Option Orientation : Vertical

Correct Marks : 4 Wrong Marks : 1

त्रिज्या R के एक गोले पर आवेश वितरित हैं जिसका

आयतनिक आवेश घनत्व $\rho(r) = \frac{A}{r^2} e^{-2r/a}$ से दिया जाता

है, जहाँ A तथा a नियतांक हैं। यदि इस आवेश वितरण का कुल आवेश Q है, तब त्रिज्या R का मान है :

Options :

$$\frac{a}{2} \log \left(1 - \frac{Q}{2\pi aA} \right)$$

41652934658.

$$\frac{a}{2} \log \left(\frac{1}{1 - \frac{Q}{2\pi aA}} \right)$$

41652934659.

$$a \log \left(1 - \frac{Q}{2\pi aA} \right)$$

41652934660.

$$a \log \left(\frac{1}{1 - \frac{Q}{2\pi aA}} \right)$$

41652934661.

Question Number : 16 Question Id : 4165298801 Question Type : MCQ Option Shuffling : Yes Display Question Number : Yes
Single Line Question Option : No Option Orientation : Vertical

Correct Marks : 4 Wrong Marks : 1

Two point charges $q_1(\sqrt{10} \mu\text{C})$ and $q_2(-25 \mu\text{C})$ are placed on the x -axis at $x=1 \text{ m}$ and $x=4 \text{ m}$ respectively. The electric field (in V/m) at a point $y=3 \text{ m}$ on y -axis is,

$$\left[\text{take } \frac{1}{4\pi\epsilon_0} = 9 \times 10^9 \text{ Nm}^2\text{C}^{-2} \right]$$

Options :

41652934662. $(-63 \hat{i} + 27 \hat{j}) \times 10^2$

41652934663. $(63 \hat{i} - 27 \hat{j}) \times 10^2$

41652934664. $(81 \hat{i} - 81 \hat{j}) \times 10^2$

41652934665. $(-81 \hat{i} + 81 \hat{j}) \times 10^2$

Question Number : 16 Question Id : 4165298801 Question Type : MCQ Option Shuffling : Yes Display Question Number : Yes
Single Line Question Option : No Option Orientation : Vertical

Correct Marks : 4 Wrong Marks : 1

दो बिन्दु आवेशों $q_1(\sqrt{10} \mu\text{C})$ तथा $q_2(-25 \mu\text{C})$ को x -अक्ष पर क्रमशः $x=1 \text{ m}$ तथा $x=4 \text{ m}$ पर रखा गया है। y -अक्ष पर बिन्दु $y=3 \text{ m}$ पर विद्युत क्षेत्र का मान (V/m में) होगा :

$$\left[\text{दिया है: } \frac{1}{4\pi\epsilon_0} = 9 \times 10^9 \text{ Nm}^2\text{C}^{-2} \right]$$

Options :

41652934662. $(-63 \hat{i} + 27 \hat{j}) \times 10^2$

41652934663. $(63 \hat{i} - 27 \hat{j}) \times 10^2$

41652934664. $(81 \hat{i} - 81 \hat{j}) \times 10^2$

41652934665. $(-81 \hat{i} + 81 \hat{j}) \times 10^2$

Question Number : 17 Question Id : 4165298802 Question Type : MCQ Option Shuffling : Yes Display Question Number : Yes
Single Line Question Option : No Option Orientation : Vertical

Correct Marks : 4 Wrong Marks : 1

In the given circuit the internal resistance of the 18 V cell is negligible. If $R_1 = 400 \Omega$, $R_3 = 100 \Omega$ and $R_4 = 500 \Omega$ and the reading of an ideal voltmeter across R_4 is 5 V, then the value of R_2 will be :

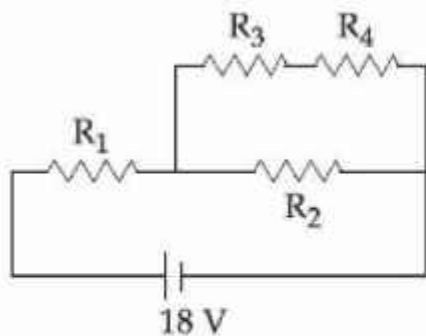

Options :

41652934666. 550 Ω

41652934667. 230 Ω

41652934668. 450 Ω

41652934669. 300 Ω

Question Number : 17 Question Id : 4165298802 Question Type : MCQ Option Shuffling : Yes Display Question Number : Yes
Single Line Question Option : No Option Orientation : Vertical

Correct Marks : 4 Wrong Marks : 1

दिये गये परिपथ में 18 V की सेल का आंतरिक प्रतिरोध नगण्य है। यदि $R_1 = 400 \Omega$, $R_3 = 100 \Omega$ तथा $R_4 = 500 \Omega$, हैं और R_4 पर लगे एक आदर्श वोल्टमीटर का पाठ्यांक 5 V है, तो R_2 का मान होगा :

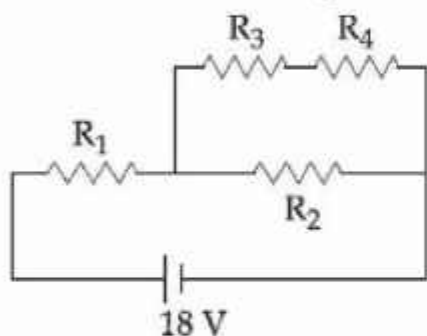

Options :

41652934666. 550 Ω

41652934667. 230 Ω

41652934668. 450 Ω

41652934669. 300Ω

Question Number : 18 Question Id : 4165298803 Question Type : MCQ Option Shuffling : Yes Display Question Number : Yes
Single Line Question Option : No Option Orientation : Vertical

Correct Marks : 4 Wrong Marks : 1

A series AC circuit containing an inductor (20 mH), a capacitor (120 μ F) and a resistor (60 Ω) is driven by an AC source of 24 V/50 Hz. The energy dissipated in the circuit in 60 s is :

Options :

41652934670. 5.65×10^2 J

41652934671. 2.26×10^3 J

41652934672. 5.17×10^2 J

41652934673. 3.39×10^3 J

Question Number : 18 Question Id : 4165298803 Question Type : MCQ Option Shuffling : Yes Display Question Number : Yes
Single Line Question Option : No Option Orientation : Vertical

Correct Marks : 4 Wrong Marks : 1

एक श्रेणीबद्ध प्रत्यावर्ती परिपथ में एक प्रेरक (20 mH), एक संधारित्र (120 μ F) तथा एक प्रतिरोध (60 Ω) लगे हैं और यह एक 24 V/50 Hz के प्रत्यावर्ती स्रोत से चालित है। 60 s समय में क्षयित ऊर्जा का मान होगा :

Options :

41652934670. 5.65×10^2 J

41652934671. 2.26×10^3 J

41652934672. 5.17×10^2 J

41652934673. 3.39×10^3 J

Question Number : 19 Question Id : 4165298804 Question Type : MCQ Option Shuffling : Yes Display Question Number : Yes
Single Line Question Option : No Option Orientation : Vertical

Correct Marks : 4 Wrong Marks : 1

One of the two identical conducting wires of length L is bent in the form of a circular loop and the other one into a circular coil of N identical turns. If the same current is passed in both, the ratio of the magnetic field at the central of the loop (B_L) to that at the centre of the coil (B_C), i.e. $\frac{B_L}{B_C}$ will be :

Options :

41652934674. N

41652934675. N^2

41652934676. $\frac{1}{N^2}$

41652934677. $\frac{1}{N}$

Question Number : 19 Question Id : 4165298804 Question Type : MCQ Option Shuffling : Yes Display Question Number : Yes
Single Line Question Option : No Option Orientation : Vertical
Correct Marks : 4 Wrong Marks : 1

लम्बाई L के दो एकसमान चालक तारों में से एक को वृत्ताकार वलय की आकृति में लाया जाता है तथा दूसरे को N एकसमान फेरों की वृत्ताकार कुंडली में मोड़ा जाता है। यदि दोनों से एक ही धारा प्रवाहित की जाती है, तो वलय तथा कुंडली के केन्द्रों पर उपस्थित चुम्बकीय

क्षेत्र, क्रमशः B_L तथा B_C हों, तब अनुपात $\frac{B_L}{B_C}$

होगा :

Options :

41652934674. N

41652934675. N^2

41652934676. $\frac{1}{N^2}$

41652934677. $\frac{1}{N}$

Question Number : 20 Question Id : 4165298805 Question Type : MCQ Option Shuffling : Yes Display Question Number : Yes
Single Line Question Option : No Option Orientation : Vertical

Correct Marks : 4 Wrong Marks : 1

A particle having the same charge as of electron moves in a circular path of radius 0.5 cm under the influence of a magnetic field of 0.5 T. If an electric field of 100 V/m makes it to move in a straight path, then the mass of the particle is (Given charge of electron = $1.6 \times 10^{-19} \text{C}$)

Options :

41652934678. $9.1 \times 10^{-31} \text{ kg}$

41652934679. $2.0 \times 10^{-24} \text{ kg}$

41652934680. $1.6 \times 10^{-19} \text{ kg}$

41652934681. $1.6 \times 10^{-27} \text{ kg}$

Question Number : 20 Question Id : 4165298805 Question Type : MCQ Option Shuffling : Yes Display Question Number : Yes
Single Line Question Option : No Option Orientation : Vertical

Correct Marks : 4 Wrong Marks : 1

एक कण, जिसका आवेश इलेक्ट्रॉन के आवेश के समान है, 0.5 T चुम्बकीय क्षेत्र में एक 0.5 cm त्रिज्या के वृत्ताकार पथ पर चलता है। यदि 100 V/m का विद्युत क्षेत्र लगाने पर यह कण एक सीधी रेखा में चलता है, तो कण का द्रव्यमान होगा :
(दिया है इलेक्ट्रॉन का आवेश = $1.6 \times 10^{-19} \text{C}$)

Options :

41652934678. $9.1 \times 10^{-31} \text{ kg}$

41652934679. $2.0 \times 10^{-24} \text{ kg}$

41652934680. $1.6 \times 10^{-19} \text{ kg}$

41652934681. $1.6 \times 10^{-27} \text{ kg}$

Question Number : 21 Question Id : 4165298806 Question Type : MCQ Option Shuffling : Yes Display Question Number : Yes
Single Line Question Option : No Option Orientation : Vertical

Correct Marks : 4 Wrong Marks : 1

A power transmission line feeds input power at 2300 V to a step down transformer with its primary windings having 4000 turns. The output power is delivered at 230 V by the transformer. If the current in the primary of the transformer is 5A and its efficiency is 90%, the output current would be :

Options :

41652934682. 35 A

41652934683. 50 A

41652934684. 45 A

41652934685. 25 A

Question Number : 21 Question Id : 4165298806 Question Type : MCQ Option Shuffling : Yes Display Question Number : Yes
Single Line Question Option : No Option Orientation : Vertical

Correct Marks : 4 Wrong Marks : 1

2300 V की एक शक्ति संचरण लाइन एक अपचायी ट्रांसफॉर्मर, जिसके प्राथमिक कुंडली में 4000 फेरें हैं, को शक्ति प्रदान करती है। ट्रांसफॉर्मर 230 V के निर्गत विभव पर शक्ति वितरण करता है। यदि ट्रांसफॉर्मर की प्राथमिक कुंडली में 5A की धारा है तथा इसकी दक्षता 90% है, तो निर्गत धारा का मान होगा :

Options :

41652934682. 35 A

41652934683. 50 A

41652934684. 45 A

41652934685. 25 A

Question Number : 22 Question Id : 4165298807 Question Type : MCQ Option Shuffling : Yes Display Question Number : Yes
Single Line Question Option : No Option Orientation : Vertical

Correct Marks : 4 Wrong Marks : 1

The energy associated with electric field is (U_E) and with magnetic field is (U_B) for an electromagnetic wave in free space. Then :

Options :

41652934686. $U_E > U_B$

41652934687. $U_E < U_B$

41652934688. $U_E = U_B$

41652934689. $U_E = \frac{U_B}{2}$

Question Number : 22 Question Id : 4165298807 Question Type : MCQ Option Shuffling : Yes Display Question Number : Yes
Single Line Question Option : No Option Orientation : Vertical

Correct Marks : 4 Wrong Marks : 1

यदि मुक्त आकाश में एक विद्युत चुम्बकीय तरंग के विद्युत क्षेत्र में निहित ऊर्जा (U_E) तथा चुम्बकीय क्षेत्र में निहित ऊर्जा (U_B) है, तो :

Options :

41652934686. $U_E > U_B$

41652934687. $U_E < U_B$

41652934688. $U_E = U_B$

41652934689. $U_E = \frac{U_B}{2}$

Question Number : 23 Question Id : 4165298808 Question Type : MCQ Option Shuffling : Yes Display Question Number : Yes
Single Line Question Option : No Option Orientation : Vertical

Correct Marks : 4 Wrong Marks : 1

Two plane mirrors are inclined to each other such that a ray of light incident on the first mirror (M_1) and parallel to the second mirror (M_2) is finally reflected from the second mirror (M_2) parallel to the first mirror (M_1). The angle between the two mirrors will be :

Options :

41652934690. 45°

41652934691. 60°

41652934692. 75°

41652934693. 90°

Question Number : 23 Question Id : 4165298808 Question Type : MCQ Option Shuffling : Yes Display Question Number : Yes
Single Line Question Option : No Option Orientation : Vertical

Correct Marks : 4 Wrong Marks : 1

दो समतल दर्पणों (M_1 तथा M_2) को परस्पर ऐसे कोण पर रखा गया है जिससे प्रकाश की एक किरण जब M_2 के समांतर जाती हुयी M_1 पर आपतित होती है तो अंततः वह M_2 से M_1 के समांतर परावर्तित होती है। दर्पणों के बीच कोण का मान होगा :

Options :

41652934690. 45°

41652934691. 60°

41652934692. 75°

41652934693. 90°

Question Number : 24 Question Id : 4165298809 Question Type : MCQ Option Shuffling : Yes Display Question Number : Yes
Single Line Question Option : No Option Orientation : Vertical

Correct Marks : 4 Wrong Marks : 1

In a Young's double slit experiment, the slits are placed 0.320 mm apart. Light of wavelength $\lambda = 500$ nm is incident on the slits. The total number of bright fringes that are observed in the angular range $-30^\circ \leq \theta \leq 30^\circ$ is :

Options :

41652934694. 320

41652934695. 321

41652934696. 640

41652934697. 641

Question Number : 24 Question Id : 4165298809 Question Type : MCQ Option Shuffling : Yes Display Question Number : Yes
Single Line Question Option : No Option Orientation : Vertical

Correct Marks : 4 Wrong Marks : 1

यंग के एक द्विझिरी उपकरण में झिरियों के बीच दूरी 0.320 mm है। तरंगदैर्घ्य $\lambda = 500$ nm का प्रकाश झिरियों पर पड़ता है। कोणीय परास $-30^\circ \leq \theta \leq 30^\circ$ में दिखने वाली दीप्त फ्रिंजों की संख्या होगी :

Options :

41652934694. 320

41652934695. 321

41652934696. 640

41652934697. 641

Question Number : 25 Question Id : 4165298810 Question Type : MCQ Option Shuffling : Yes Display Question Number : Yes
Single Line Question Option : No Option Orientation : Vertical

Correct Marks : 4 Wrong Marks : 1

The magnetic field associated with a light wave is given, at the origin, by

$$B = B_0 [\sin(3.14 \times 10^7)ct + \sin(6.28 \times 10^7)ct].$$

If this light falls on a silver plate having a work function of 4.7 eV, what will be the maximum kinetic energy of the photo electrons ?

$$(c = 3 \times 10^8 \text{ ms}^{-1}, h = 6.6 \times 10^{-34} \text{ J-s})$$

Options :

41652934698. 7.72 eV

41652934699. 8.52 eV

41652934700. 12.5 eV

41652934701. 6.82 eV

Question Number : 25 Question Id : 4165298810 Question Type : MCQ Option Shuffling : Yes Display Question Number : Yes
Single Line Question Option : No Option Orientation : Vertical

Correct Marks : 4 Wrong Marks : 1

मूलबिंदु पर एक प्रकाशीय तरंग के संगत चुम्बकीय क्षेत्र निम्न है :

$$B = B_0 [\sin(3.14 \times 10^7)ct + \sin(6.28 \times 10^7)ct].$$

यदि यह प्रकाश एक चाँदी की प्लेट, जिसका कार्य फलन 4.7 eV है, पर पड़ता है तो इससे उत्सर्जित फोटोइलेक्ट्रॉनों की अधिकतम गतिज ऊर्जा क्या होगी ?

$$(दिया है : c = 3 \times 10^8 \text{ ms}^{-1}, h = 6.6 \times 10^{-34} \text{ J-s})$$

Options :

41652934698. 7.72 eV

41652934699. 8.52 eV

41652934700. 12.5 eV

41652934701. 6.82 eV

Question Number : 26 Question Id : 4165298811 Question Type : MCQ Option Shuffling : Yes Display Question Number : Yes
Single Line Question Option : No Option Orientation : Vertical

Correct Marks : 4 Wrong Marks : 1

At a given instant, say $t = 0$, two radioactive substances A and B have equal activities.

The ratio $\frac{R_B}{R_A}$ of their activities after

time t itself decays with time t as e^{-3t} . If the half-life of A is $\ln 2$, the half-life of B is :

Options :

41652934702. $\frac{\ln 2}{4}$

41652934703. $\frac{\ln 2}{2}$

41652934704. $2\ln 2$

41652934705. $4\ln 2$

Question Number : 26 Question Id : 4165298811 Question Type : MCQ Option Shuffling : Yes Display Question Number : Yes
Single Line Question Option : No Option Orientation : Vertical

Correct Marks : 4 Wrong Marks : 1

दिये गये एक क्षण, $t = 0$ पर दो रेडियोधर्मी पदार्थों, A तथा B, की सक्रियता बराबर है। समय t के पश्चात,

इनकी सक्रियता का अनुपात $\frac{R_B}{R_A}$ समय t के साथ

e^{-3t} के अनुसार घटता है। यदि A की अर्धआयु $\ln 2$ है, तो B की अर्धआयु होगी :

Options :

41652934702. $\frac{\ln 2}{4}$

41652934703. $\frac{\ln 2}{2}$

41652934704. $2/n^2$

41652934705. $4/n^2$

Question Number : 27 Question Id : 4165298812 Question Type : MCQ Option Shuffling : Yes Display Question Number : Yes
Single Line Question Option : No Option Orientation : Vertical

Correct Marks : 4 Wrong Marks : 1

Ge and Si diodes start conducting at 0.3 V and 0.7 V respectively. In the following figure if Ge diode connection are reversed, the value of V_o changes by : (assume that the Ge diode has large breakdown voltage)

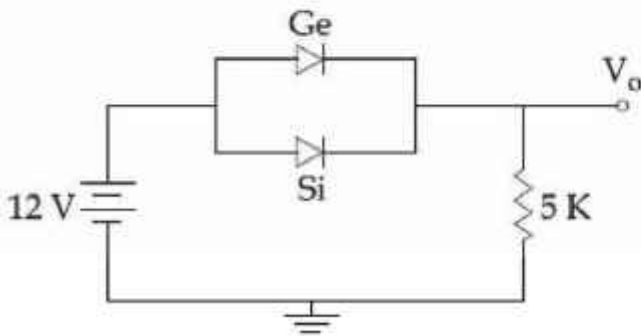

Options :

41652934706. 0.4 V

41652934707. 0.2 V

41652934708. 0.6 V

41652934709. 0.8 V

Question Number : 27 Question Id : 4165298812 Question Type : MCQ Option Shuffling : Yes Display Question Number : Yes
Single Line Question Option : No Option Orientation : Vertical

Correct Marks : 4 Wrong Marks : 1

Ge तथा Si के डायोड, क्रमशः 0.3 V तथा 0.7 V पर सुचालक हो जाते हैं। दिय गये चित्र में यदि Ge डायोड के सिरों को पलट दिया जाये तो विभव V_o में परिवर्तन का मान होगा : (मान लें कि Ge डायोड की भंजन वोल्टता अत्यधिक है।)

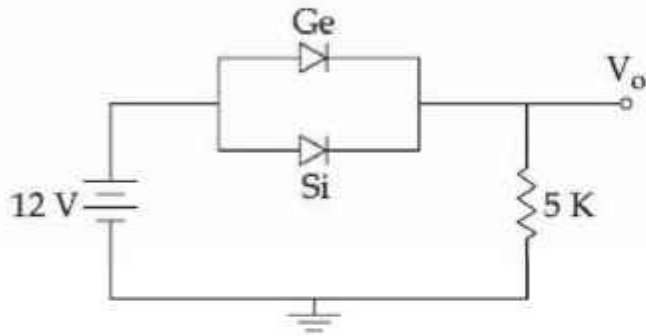

Options :

41652934706. 0.4 V

41652934707. 0.2 V

41652934708. 0.6 V

41652934709. 0.8 V

Question Number : 28 Question Id : 4165298813 Question Type : MCQ Option Shuffling : Yes Display Question Number : Yes Single Line Question Option : No Option Orientation : Vertical

Correct Marks : 4 Wrong Marks : 1

In a communication system operating at wavelength 800 nm, only one percent of source frequency is available as signal bandwidth. The number of channels accommodated for transmitting TV signals of band width 6 MHz are (Take velocity of light $c = 3 \times 10^8 \text{ m/s}$, $h = 6.6 \times 10^{-34} \text{ J-s}$)

Options :

41652934710. 6.25×10^5

41652934711. 3.86×10^6

41652934712. 4.87×10^5

41652934713. 3.75×10^6

Question Number : 28 Question Id : 4165298813 Question Type : MCQ Option Shuffling : Yes Display Question Number : Yes Single Line Question Option : No Option Orientation : Vertical

Correct Marks : 4 Wrong Marks : 1

800 nm तरंगदैर्घ्य पर कार्य करते हुए एक संचार व्यवस्था में सिग्नल की कुल स्रोत आवृत्ति का मात्र एक प्रतिशत बैंड चौड़ाई के लिए उपयोग कर सकते हैं। 6 MHz बैंड चौड़ाई के TV सिग्नलों वाले कितने चैनलों को इससे संचारित किया जा सकता है? (दिया है : $c = 3 \times 10^8 \text{ m/s}$, $h = 6.6 \times 10^{-34} \text{ J-s}$)

Options :

41652934710. 6.25×10^5

41652934711. 3.86×10^6

41652934712. 4.87×10^5

41652934713. 3.75×10^6

Question Number : 29 Question Id : 4165298814 Question Type : MCQ Option Shuffling : Yes Display Question Number : Yes
Single Line Question Option : No Option Orientation : Vertical
Correct Marks : 4 Wrong Marks : 1

A carbon resistance has a following colour code. What is the value of the resistance ?

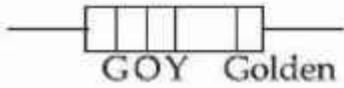

Options :

41652934714. $6.4 \text{ M}\Omega \pm 5\%$

41652934715. $530 \text{ k}\Omega \pm 5\%$

41652934716. $64 \text{ k}\Omega \pm 10\%$

41652934717. $5.3 \text{ M}\Omega \pm 5\%$

Question Number : 29 Question Id : 4165298814 Question Type : MCQ Option Shuffling : Yes Display Question Number : Yes
Single Line Question Option : No Option Orientation : Vertical
Correct Marks : 4 Wrong Marks : 1

एक कार्बन प्रतिरोध का कलर कोड निम्न है। इसके प्रतिरोध का मान होगा :

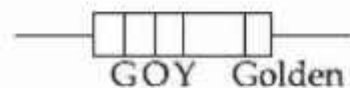

Options :

41652934714. $6.4 \text{ M}\Omega \pm 5\%$

41652934715. 530 k Ω \pm 5%

41652934716. 64 k Ω \pm 10%

41652934717. 5.3 M Ω \pm 5%

Question Number : 30 Question Id : 4165298815 Question Type : MCQ Option Shuffling : Yes Display Question Number : Yes
Single Line Question Option : No Option Orientation : Vertical

Correct Marks : 4 Wrong Marks : 1

The pitch and the number of divisions, on the circular scale, for a given screw gauge are 0.5 mm and 100 respectively. When the screw gauge is fully tightened without any object, the zero of its circular scale lies 3 divisions below the mean line.

The readings of the main scale and the circular scale, for a thin sheet, are 5.5 mm and 48 respectively, the thickness of this sheet is :

Options :

41652934718. 5.725 mm

41652934719. 5.755 mm

41652934720. 5.950 mm

41652934721. 5.740 mm

Question Number : 30 Question Id : 4165298815 Question Type : MCQ Option Shuffling : Yes Display Question Number : Yes
Single Line Question Option : No Option Orientation : Vertical

Correct Marks : 4 Wrong Marks : 1

एक पेचमापी की पिच तथा वृत्तीय पैमाने पर भागों की संख्या, क्रमशः 0.5 mm तथा 100 है। जब पेचमापी को बिना किसी वस्तु के पूरी तरह कस दिया जाता है, तो इसके वृत्तीय पैमाने का शून्य मध्य रेखा से तीन भाग नीचे आता है।

एक पतली चदर की मोटाई के लिए इस पेचमापी के मुख्य पैमाने तथा वृत्तीय पैमाने का पाठ्यांक, क्रमशः 5.5 mm तथा 48 हैं। तो चदर की मोटाई होगी :

Options :

41652934718. 5.725 mm

41652934719. 5.755 mm

41652934720. 5.950 mm

41652934721. 5.740 mm

Section Id :	Chemistry
Section Number :	416529116
Section type :	2
Mandatory or Optional:	Online
Number of Questions:	Mandatory
Number of Questions to be attempted:	30
Section Marks:	30
Display Number Panel:	120
Group All Questions:	Yes
	No

Sub-Section Number:	1
Sub-Section Id:	416529125
Question Shuffling Allowed :	Yes

Question Number : 31 Question Id : 4165298816 Question Type : MCQ Option Shuffling : Yes Display Question Number : Yes
Single Line Question Option : No Option Orientation : Vertical

Correct Marks : 4 Wrong Marks : 1

The major product of the following reaction is :

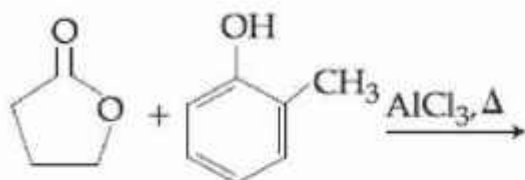

Options :

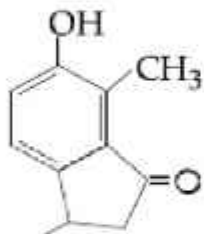

41652934722.

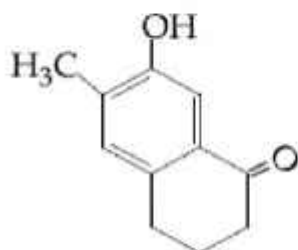

41652934723.

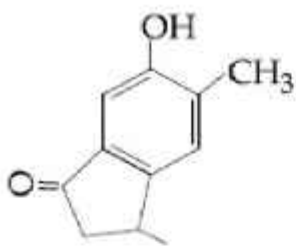

41652934724.

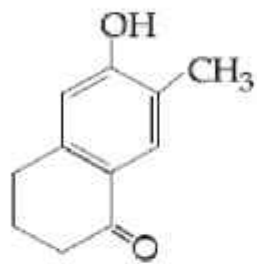

41652934725.

Question Number : 31 Question Id : 4165298816 Question Type : MCQ Option Shuffling : Yes Display Question Number : Yes
 Single Line Question Option : No Option Orientation : Vertical
 Correct Marks : 4 Wrong Marks : 1

निम्नलिखित अभिक्रिया का मुख्य उत्पाद है :

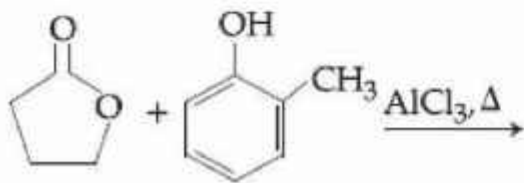

Options :

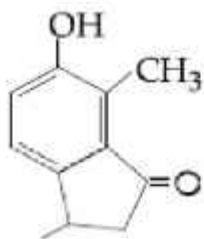

41652934722.

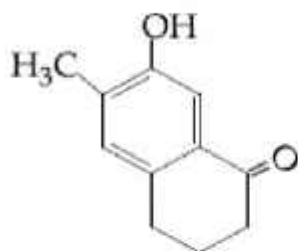

41652934723.

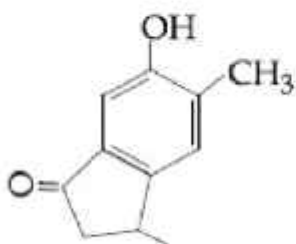

41652934724.

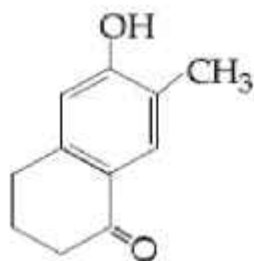

41652934725.

Question Number : 32 Question Id : 4165298817 Question Type : MCQ Option Shuffling : Yes Display Question Number : Yes
Single Line Question Option : No Option Orientation : Vertical

Correct Marks : 4 Wrong Marks : 1

Which of the following compounds is not aromatic ?

Options :

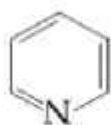

41652934726.



41652934727.



41652934728.



41652934729.

Question Number : 32 Question Id : 4165298817 Question Type : MCQ Option Shuffling : Yes Display Question Number : Yes
Single Line Question Option : No Option Orientation : Vertical

Correct Marks : 4 Wrong Marks : 1

निम्न में से कौन सा यौगिक ऐरोमैटिक नहीं है ?

Options :



41652934726.



41652934727.

41652934728.



41652934729.



Question Number : 33 Question Id : 4165298818 Question Type : MCQ Option Shuffling : Yes Display Question Number : Yes
Single Line Question Option : No Option Orientation : Vertical

Correct Marks : 4 Wrong Marks : 1

The major product of the following reaction
is :

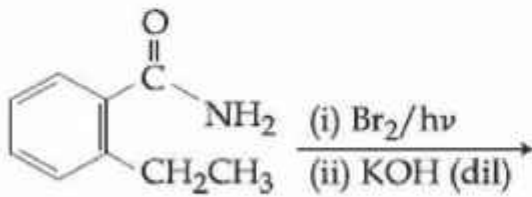

Options :

41652934730.

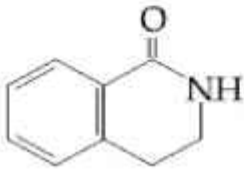

41652934731.

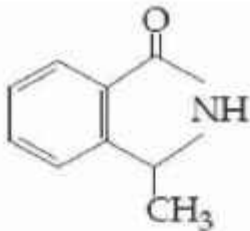

41652934732.

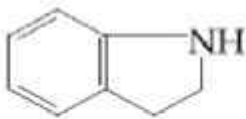

41652934733.

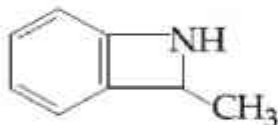

Question Number : 33 Question Id : 4165298818 Question Type : MCQ Option Shuffling : Yes Display Question Number : Yes
Single Line Question Option : No Option Orientation : Vertical

Correct Marks : 4 Wrong Marks : 1

निम्नलिखित अभिक्रिया का मुख्य उत्पाद है :

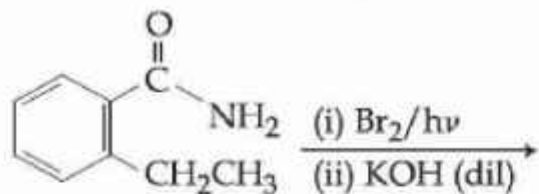

Options :

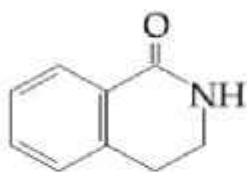

41652934730.

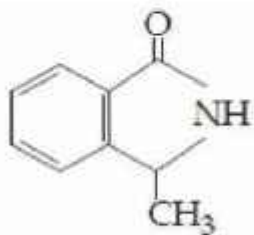

41652934731.

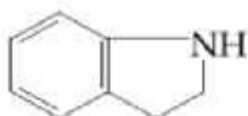

41652934732.

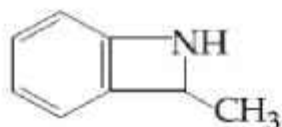

41652934733.

Question Number : 34 Question Id : 4165298819 Question Type : MCQ Option Shuffling : Yes Display Question Number : Yes
Single Line Question Option : No Option Orientation : Vertical

Correct Marks : 4 Wrong Marks : 1

The products formed in the reaction of cumene with O_2 followed by treatment with dil. HCl are :

Options :

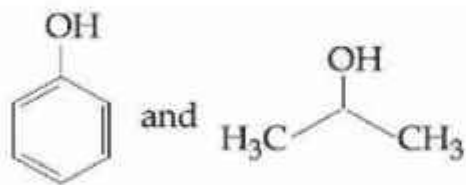

41652934734.

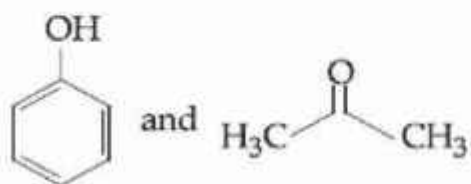

41652934735.

41652934736.

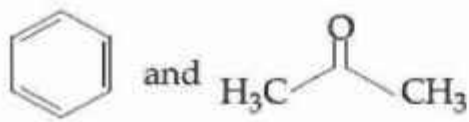

41652934737.

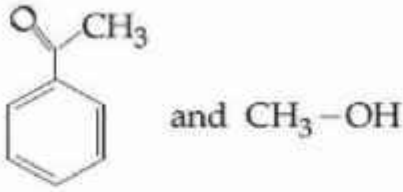

Question Number : 34 Question Id : 4165298819 Question Type : MCQ Option Shuffling : Yes Display Question Number : Yes
Single Line Question Option : No Option Orientation : Vertical

Correct Marks : 4 Wrong Marks : 1

क्यूमीन को O_2 के साथ अभिक्रिया करने के तत्पश्चात् तनु HCl के साथ विवेचन करने पर बनने वाले उत्पाद हैं :

Options :

41652934734.

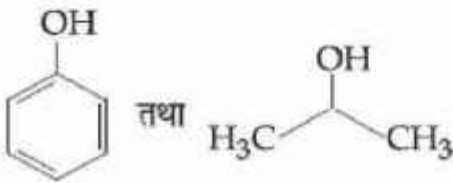

41652934735.

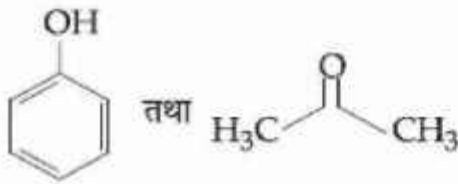

41652934736.

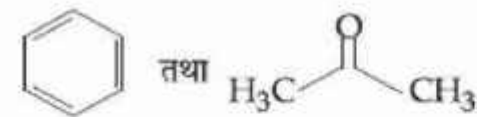

41652934737.

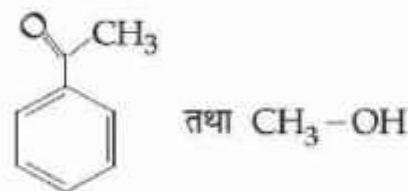

Question Number : 35 Question Id : 4165298820 Question Type : MCQ Option Shuffling : Yes Display Question Number : Yes
Single Line Question Option : No Option Orientation : Vertical

Correct Marks : 4 Wrong Marks : 1

The major product formed in the following reaction is :

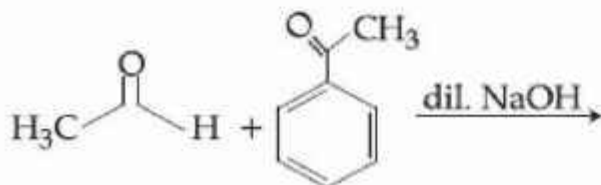

Options :

41652934738.

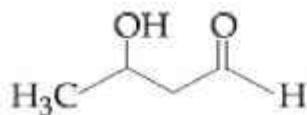

41652934739.

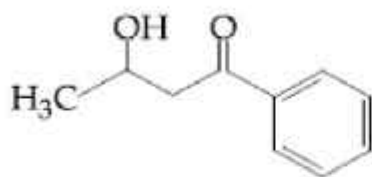

41652934740.

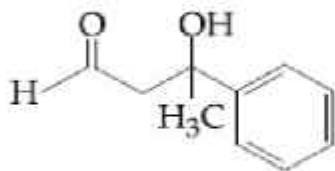

41652934741.

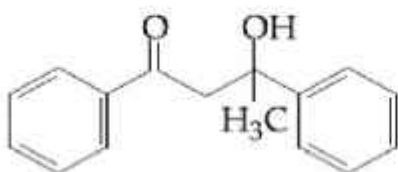

Question Number : 35 Question Id : 4165298820 Question Type : MCQ Option Shuffling : Yes Display Question Number : Yes
Single Line Question Option : No Option Orientation : Vertical

Correct Marks : 4 Wrong Marks : 1

निम्नलिखित अभिक्रिया का मुख्य उत्पाद है :

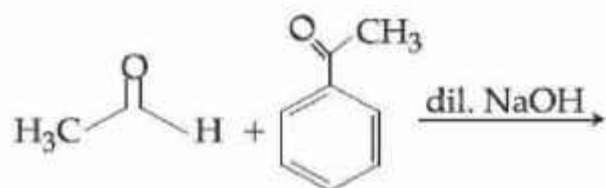

Options :

41652934738.

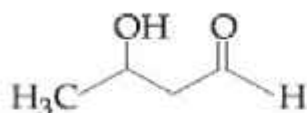

41652934739.

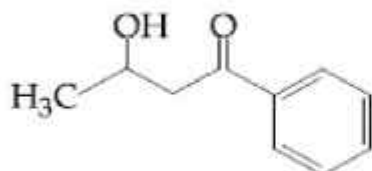

41652934740.

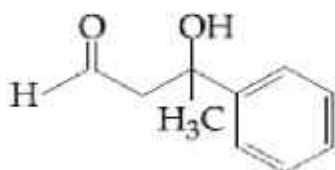

41652934741.

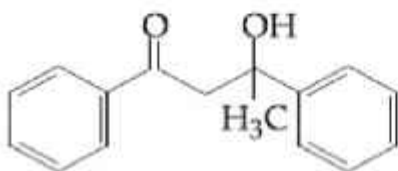

Question Number : 36 Question Id : 4165298821 Question Type : MCQ Option Shuffling : Yes Display Question Number : Yes
Single Line Question Option : No Option Orientation : Vertical

Correct Marks : 4 Wrong Marks : 1

The increasing basicity order of the following compounds is :

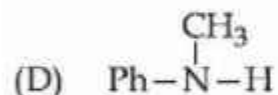
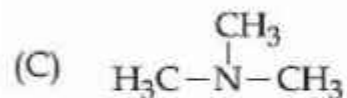
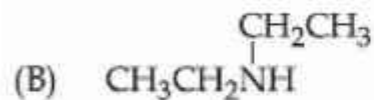
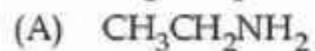

Options :

41652934742. (A)<(B)<(D)<(C)

41652934743. (D)<(C)<(B)<(A)

41652934744. (D)<(C)<(A)<(B)

41652934745. (A)<(B)<(C)<(D)

Question Number : 36 Question Id : 4165298821 Question Type : MCQ Option Shuffling : Yes Display Question Number : Yes
Single Line Question Option : No Option Orientation : Vertical

Correct Marks : 4 Wrong Marks : 1

निम्नलिखित यौगिकों में क्षारकता का बढ़ता क्रम है :

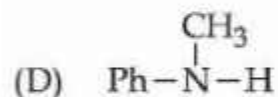
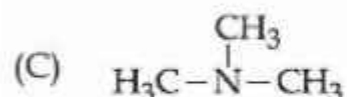
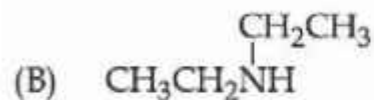

Options :

41652934742. (A)<(B)<(D)<(C)

41652934743. (D)<(C)<(B)<(A)

41652934744. (D)<(C)<(A)<(B)

41652934745. (A)<(B)<(C)<(D)

Question Number : 37 Question Id : 4165298822 Question Type : MCQ Option Shuffling : Yes Display Question Number : Yes
Single Line Question Option : No Option Orientation : Vertical

Correct Marks : 4 Wrong Marks : 1

The correct sequence of amino acids present in the tripeptide given below is :

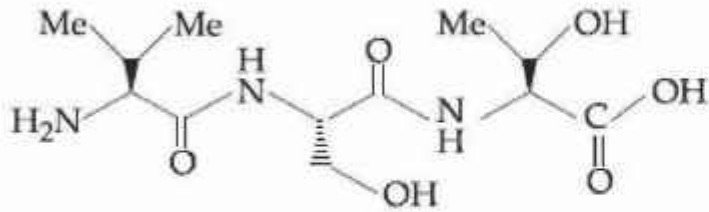

Options :

41652934746. Leu - Ser - Thr

41652934747. Thr - Ser- Leu

41652934748. Val - Ser - Thr

41652934749. Thr - Ser - Val

Question Number : 37 Question Id : 4165298822 Question Type : MCQ Option Shuffling : Yes Display Question Number : Yes
Single Line Question Option : No Option Orientation : Vertical

Correct Marks : 4 Wrong Marks : 1

नीचे दिये ट्राइपेप्टाइड में ऐमीनो अम्लों का सही क्रम है :

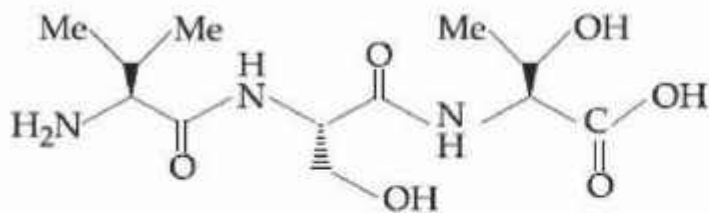

Options :

41652934746. Leu - Ser - Thr

41652934747. Thr - Ser- Leu

41652934748. Val - Ser - Thr

41652934749. Thr - Ser - Val

Question Number : 38 Question Id : 4165298823 Question Type : MCQ Option Shuffling : Yes Display Question Number : Yes
Single Line Question Option : No Option Orientation : Vertical

Correct Marks : 4 Wrong Marks : 1

The tests performed on compound X and their inferences are :

Test	Inference
(a) 2, 4 - DNP test	Coloured precipitate
(b) Iodoform test	Yellow precipitate
(c) Azo-dye test	No dye formation

Compound 'X' is :

Options :

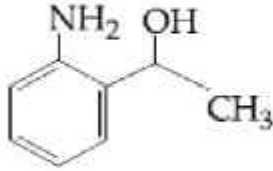

41652934750.

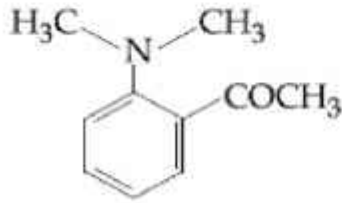

41652934751.

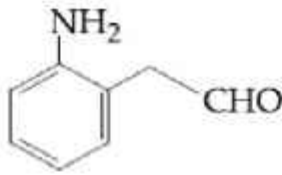

41652934752.

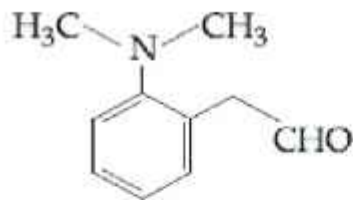

41652934753.

Question Number : 38 Question Id : 4165298823 Question Type : MCQ Option Shuffling : Yes Display Question Number : Yes
Single Line Question Option : No Option Orientation : Vertical

Correct Marks : 4 Wrong Marks : 1

यौगिक X पर किये गये परीक्षण निम्न निष्कर्ष देते हैं :

परीक्षण	निष्कर्ष
(a) 2, 4 - DNP परीक्षण	रंगीन अवक्षेप
(b) आयडोफार्म परीक्षण	पीला अवक्षेप बनना
(c) ऐजो-डाई परीक्षण	डाई नहीं बनना

यौगिक 'X' है :

Options :

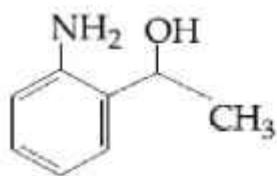

41652934750.

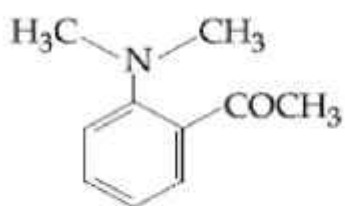

41652934751.

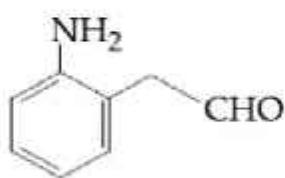

41652934752.

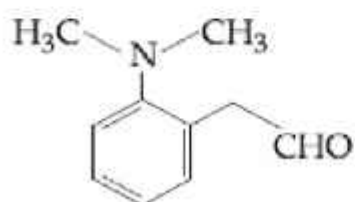

41652934753.

Question Number : 39 Question Id : 4165298824 Question Type : MCQ Option Shuffling : Yes Display Question Number : Yes
Single Line Question Option : No Option Orientation : Vertical

Correct Marks : 4 Wrong Marks : 1

The major product obtained in the following reaction is :

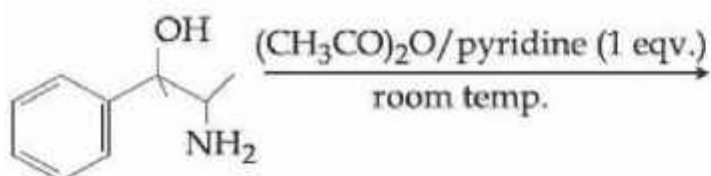

Options :

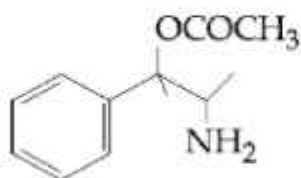

41652934754.

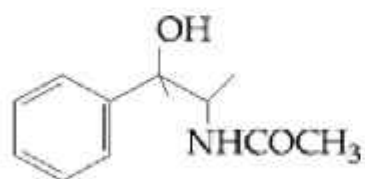

41652934755.

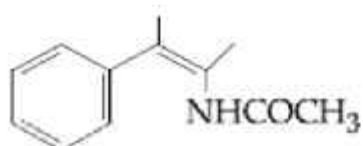

41652934756.

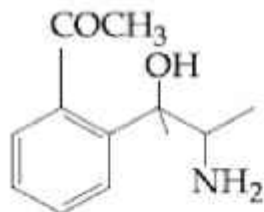

41652934757.

Question Number : 39 Question Id : 4165298824 Question Type : MCQ Option Shuffling : Yes Display Question Number : Yes
Single Line Question Option : No Option Orientation : Vertical

Correct Marks : 4 Wrong Marks : 1

निम्न अभिक्रिया में प्राप्त होने वाला मुख्य उत्पाद है :

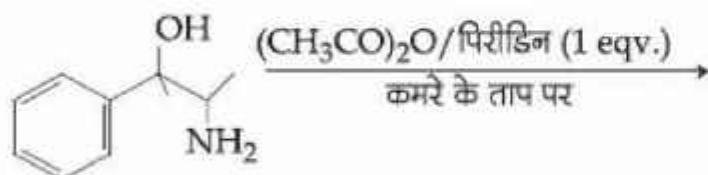

Options :

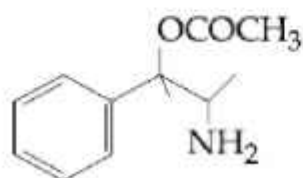

41652934754.

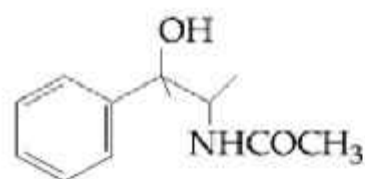

41652934755.

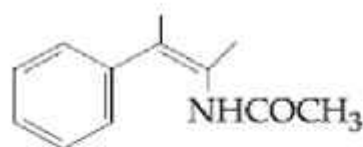

41652934756.



41652934757.

Question Number : 40 Question Id : 4165298825 Question Type : MCQ Option Shuffling : Yes Display Question Number : Yes
Single Line Question Option : No Option Orientation : Vertical

Correct Marks : 4 Wrong Marks : 1

The correct match between Item I and Item II is :

Item I	Item II
(A) Benzaldehyde	(P) Mobile phase
(B) Alumina	(Q) Adsorbent
(C) Acetonitrile	(R) Adsorbate

Options :

41652934758. (A) \rightarrow (P) ; (B) \rightarrow (R) ; (C) \rightarrow (Q)

41652934759. (A) \rightarrow (Q) ; (B) \rightarrow (P) ; (C) \rightarrow (R)

41652934760. (A) \rightarrow (Q) ; (B) \rightarrow (R) ; (C) \rightarrow (P)

41652934761. (A) \rightarrow (R) ; (B) \rightarrow (Q) ; (C) \rightarrow (P)

Question Number : 40 Question Id : 4165298825 Question Type : MCQ Option Shuffling : Yes Display Question Number : Yes
Single Line Question Option : No Option Orientation : Vertical

Correct Marks : 4 Wrong Marks : 1

मद I तथा मद II के बीच सही सुमेल है :

मद I	मद II
(A) बेंजाल्डहाइड	(P) गतिशील प्रावस्था
(B) एल्युमिना	(Q) अधिशोषक
(C) ऐसिटोनाइट्राइल	(R) अधिशोष्य

Options :

41652934758. (A) \rightarrow (P) ; (B) \rightarrow (R) ; (C) \rightarrow (Q)

41652934759. (A) \rightarrow (Q) ; (B) \rightarrow (P) ; (C) \rightarrow (R)

41652934760. (A) \rightarrow (Q) ; (B) \rightarrow (R) ; (C) \rightarrow (P)

41652934761. (A) \rightarrow (R) ; (B) \rightarrow (Q) ; (C) \rightarrow (P)

Question Number : 41 Question Id : 4165298826 Question Type : MCQ Option Shuffling : Yes Display Question Number : Yes
Single Line Question Option : No Option Orientation : Vertical

Correct Marks : 4 Wrong Marks : 1

When the first electron gain enthalpy ($\Delta_{eg}H$) of oxygen is -141 kJ/mol, its second electron gain enthalpy is :

Options :

41652934762. a positive value

41652934763. a more negative value than the first

41652934764. negative, but less negative than the first

41652934765. almost the same as that of the first

Question Number : 41 Question Id : 4165298826 Question Type : MCQ Option Shuffling : Yes Display Question Number : Yes
 Single Line Question Option : No Option Orientation : Vertical

Correct Marks : 4 Wrong Marks : 1

यदि आक्सीजन की प्रथम इलेक्ट्रान लब्धि एंथैल्पी ($\Delta_{eg}H$) का मान -141 kJ/mol है, इसके द्वितीय इलेक्ट्रान लब्धि एन्थैल्पी का मान है :

Options :

41652934762. धनात्मक

41652934763. पहले से और ऋणात्मक

41652934764. ऋणात्मक लेकिन पहले से कम ऋणात्मक

41652934765. पहले मान के लगभग बराबर

Question Number : 42 Question Id : 4165298827 Question Type : MCQ Option Shuffling : Yes Display Question Number : Yes
 Single Line Question Option : No Option Orientation : Vertical

Correct Marks : 4 Wrong Marks : 1

The correct statement regarding the given Ellingham diagram is :

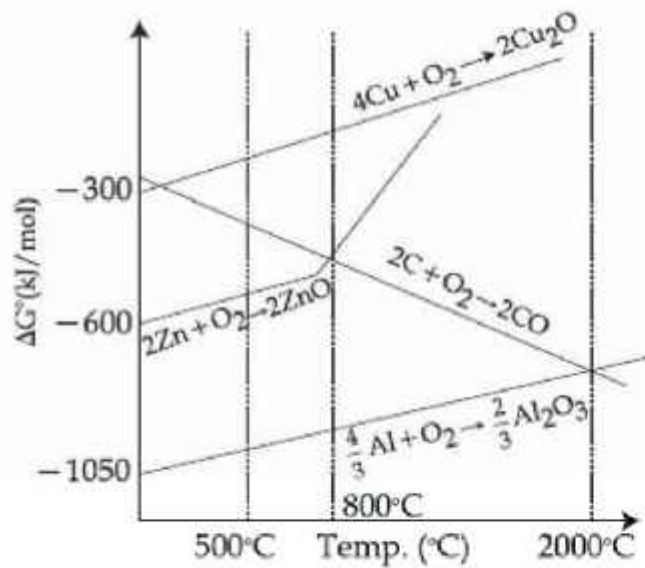

Options :

41652934766. Coke cannot be used for the extraction of Cu from Cu_2O .

41652934767. At 1400°C , Al can be used for the extraction of Zn from ZnO

41652934768. At 500°C , coke can be used for the extraction of Zn from ZnO

41652934769. At 800°C , Cu can be used for the extraction of Zn from ZnO.

Question Number : 42 Question Id : 4165298827 Question Type : MCQ Option Shuffling : Yes Display Question Number : Yes
Single Line Question Option : No Option Orientation : Vertical

Correct Marks : 4 Wrong Marks : 1

दिए गए आरेखीय एलिंघम आलेख के संबंध में सत्य कथन है :

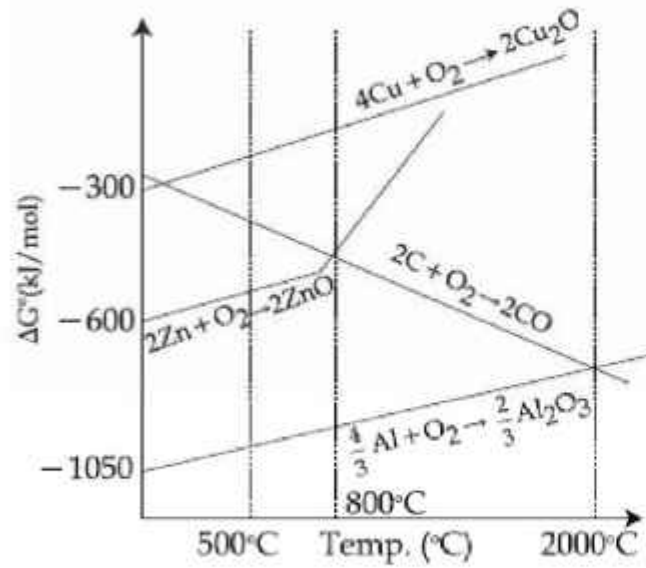

Options :

41652934766. Cu_2O से Cu का निष्कर्षण कोक का प्रयोग करके नहीं किया जा सकता है।
41652934767. ZnO से Zn का निष्कर्षण 1400°C पर Al का प्रयोग करके किया जा सकता है।
41652934768. ZnO से Zn का निष्कर्षण 500°C पर कोक का प्रयोग करके किया जा सकता है।
41652934769. ZnO से Zn का निष्कर्षण 800°C पर Cu का प्रयोग करके किया जा सकता है।

Question Number : 43 Question Id : 4165298828 Question Type : MCQ Option Shuffling : Yes Display Question Number : Yes
Single Line Question Option : No Option Orientation : Vertical

Correct Marks : 4 Wrong Marks : 1

The temporary hardness of water is due to :

Options :

41652934770. CaCl_2
41652934771. $\text{Ca}(\text{HCO}_3)_2$
41652934772. NaCl
41652934773. Na_2SO_4

Question Number : 43 Question Id : 4165298828 Question Type : MCQ Option Shuffling : Yes Display Question Number : Yes
Single Line Question Option : No Option Orientation : Vertical

Correct Marks : 4 Wrong Marks : 1

पानी की अस्थायी कठोरता का कारण है :

Options :

41652934770. CaCl_2

41652934771. $\text{Ca}(\text{HCO}_3)_2$

41652934772. NaCl

41652934773. Na_2SO_4

Question Number : 44 Question Id : 4165298829 Question Type : MCQ Option Shuffling : Yes Display Question Number : Yes
Single Line Question Option : No Option Orientation : Vertical

Correct Marks : 4 Wrong Marks : 1

The metal that forms nitride by reacting directly with N_2 of air, is :

Options :

41652934774. K

41652934775. Rb

41652934776. Cs

41652934777. Li

Question Number : 44 Question Id : 4165298829 Question Type : MCQ Option Shuffling : Yes Display Question Number : Yes
Single Line Question Option : No Option Orientation : Vertical

Correct Marks : 4 Wrong Marks : 1

वह धातु जो हवा की N_2 से सीधे अभिक्रिया कर नाइट्राइड बनाता है, है :

Options :

41652934774. K

41652934775. Rb

41652934776. Cs

41652934777. Li

Question Number : 45 Question Id : 4165298830 Question Type : MCQ Option Shuffling : Yes Display Question Number : Yes
Single Line Question Option : No Option Orientation : Vertical

Correct Marks : 4 Wrong Marks : 1

Good reducing nature of H_3PO_2 is attributed to the presence of :

Options :

41652934778. One P – H bond
41652934779. Two P – H bonds
41652934780. One P – OH bond
41652934781. Two P – OH bonds

Question Number : 45 Question Id : 4165298830 Question Type : MCQ Option Shuffling : Yes Display Question Number : Yes
Single Line Question Option : No Option Orientation : Vertical

Correct Marks : 4 Wrong Marks : 1

H_3PO_2 की अच्छी अपचायक प्रवृत्ति किनकी उपस्थिति के कारण है?

Options :

41652934778. एक P – H आबंध
41652934779. दो P – H आबंध
41652934780. एक P – OH आबंध
41652934781. दो P – OH आबंध

Question Number : 46 Question Id : 4165298831 Question Type : MCQ Option Shuffling : Yes Display Question Number : Yes
Single Line Question Option : No Option Orientation : Vertical

Correct Marks : 4 Wrong Marks : 1

The transition element that has lowest enthalpy of atomisation, is :

Options :

41652934782. V
41652934783. Cu
41652934784. Zn
41652934785. Fe

Question Number : 46 Question Id : 4165298831 Question Type : MCQ Option Shuffling : Yes Display Question Number : Yes
Single Line Question Option : No Option Orientation : Vertical

Correct Marks : 4 Wrong Marks : 1

न्यूनतम कणन एन्थैल्पी रखने वाला संक्रमण तत्व है :

Options :

41652934782. V

41652934783. Cu

41652934784. Zn

41652934785. Fe

Question Number : 47 Question Id : 4165298832 Question Type : MCQ Option Shuffling : Yes Display Question Number : Yes
Single Line Question Option : No Option Orientation : Vertical

Correct Marks : 4 Wrong Marks : 1

The complex that has highest crystal field splitting energy (Δ), is :

Options :

41652934786. $K_2[CoCl_4]$

41652934787. $K_3[Co(CN)_6]$

41652934788. $[Co(NH_3)_5Cl]Cl_2$

41652934789. $[Co(NH_3)_5(H_2O)]Cl_3$

Question Number : 47 Question Id : 4165298832 Question Type : MCQ Option Shuffling : Yes Display Question Number : Yes
Single Line Question Option : No Option Orientation : Vertical

Correct Marks : 4 Wrong Marks : 1

अधिकतम क्रिस्टल क्षेत्र विपाटन ऊर्जा (Δ) रखने वाला संकुल है :

Options :

41652934786. $K_2[CoCl_4]$

41652934787. $K_3[Co(CN)_6]$

41652934788. $[Co(NH_3)_5Cl]Cl_2$

41652934789. $[Co(NH_3)_5(H_2O)]Cl_3$

Question Number : 48 Question Id : 4165298833 Question Type : MCQ Option Shuffling : Yes Display Question Number : Yes
Single Line Question Option : No Option Orientation : Vertical

Correct Marks : 4 Wrong Marks : 1

Homoleptic octahedral complexes of a metal ion ' M^{3+} ' with three monodentate ligands L_1 , L_2 and L_3 absorb wavelengths in the region of green, blue and red respectively. The increasing order of the ligand strength is :

Options :

41652934790. $L_1 < L_2 < L_3$

41652934791. $L_3 < L_2 < L_1$

41652934792. $L_2 < L_1 < L_3$

41652934793. $L_3 < L_1 < L_2$

Question Number : 48 Question Id : 4165298833 Question Type : MCQ Option Shuffling : Yes Display Question Number : Yes
Single Line Question Option : No Option Orientation : Vertical

Correct Marks : 4 Wrong Marks : 1

तीन एकदंतुर लिगण्डों L_1 , L_2 तथा L_3 के साथ बने एक धातु आयन ' M^{3+} ' के होमोलेप्टिक अष्टफलक संकुल क्रमशः हरे, नीले एवं लाल क्षेत्र के तरंगदैर्घ्य अवशोषित करते हैं। लिगण्डों की प्रबलता का बढ़ता क्रम है :

Options :

41652934790. $L_1 < L_2 < L_3$

41652934791. $L_3 < L_2 < L_1$

41652934792. $L_2 < L_1 < L_3$

41652934793. $L_3 < L_1 < L_2$

Question Number : 49 Question Id : 4165298834 Question Type : MCQ Option Shuffling : Yes Display Question Number : Yes
Single Line Question Option : No Option Orientation : Vertical

Correct Marks : 4 Wrong Marks : 1

Which of the following conditions in drinking water causes methemoglobinemia ?

Options :

41652934794. > 100 ppm of sulphate

41652934795. > 50 ppm of lead

41652934796. > 50 ppm of nitrate

41652934797. > 50 ppm of chloride

Question Number : 49 Question Id : 4165298834 Question Type : MCQ Option Shuffling : Yes Display Question Number : Yes
Single Line Question Option : No Option Orientation : Vertical

Correct Marks : 4 Wrong Marks : 1

पीने के पानी से मेथेमोग्लोबिनेमिया होने के कारण की शर्त है :

Options :

41652934794. > 100 ppm सल्फेट

41652934795. > 50 ppm लेड

41652934796. > 50 ppm नाइट्रेट

41652934797. > 50 ppm क्लोराइड

Question Number : 50 Question Id : 4165298835 Question Type : MCQ Option Shuffling : Yes Display Question Number : Yes
Single Line Question Option : No Option Orientation : Vertical

Correct Marks : 4 Wrong Marks : 1

The pH of rain water, is approximately :

Options :

41652934798. 7.0

41652934799. 7.5

41652934800. 6.5

41652934801. 5.6

Question Number : 50 Question Id : 4165298835 Question Type : MCQ Option Shuffling : Yes Display Question Number : Yes
Single Line Question Option : No Option Orientation : Vertical

Correct Marks : 4 Wrong Marks : 1

वर्षा के पानी की pH लगभग है :

Options :

41652934798. 7.0

41652934799. 7.5

41652934800. 6.5

41652934801. 5.6

Question Number : 51 Question Id : 4165298836 Question Type : MCQ Option Shuffling : Yes Display Question Number : Yes
Single Line Question Option : No Option Orientation : Vertical

Correct Marks : 4 Wrong Marks : 1

For the following reaction, the mass of water produced from 445 g of $C_{57}H_{110}O_6$ is :

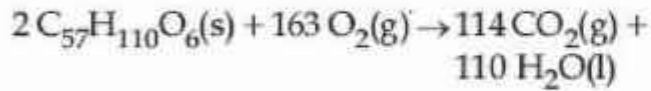

Options :

41652934802. 445 g

41652934803. 495 g

41652934804. 490 g

41652934805. 890 g

Question Number : 51 Question Id : 4165298836 Question Type : MCQ Option Shuffling : Yes Display Question Number : Yes
Single Line Question Option : No Option Orientation : Vertical

Correct Marks : 4 Wrong Marks : 1

निम्न अभिक्रिया के लिए, 445 g $C_{57}H_{110}O_6$ से उत्पादित जल का द्रव्यमान है :

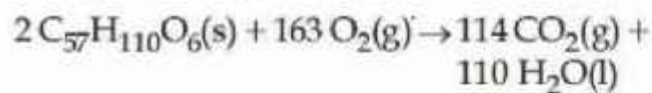

Options :

41652934802. 445 g

41652934803. 495 g

41652934804. 490 g

41652934805. 890 g

Question Number : 52 Question Id : 4165298837 Question Type : MCQ Option Shuffling : Yes Display Question Number : Yes
Single Line Question Option : No Option Orientation : Vertical

Correct Marks : 4 Wrong Marks : 1

At 100°C , copper (Cu) has FCC unit cell structure with cell edge length of $x \text{ \AA}$. What is the approximate density of Cu (in g cm^{-3}) at this temperature ?

[Atomic Mass of Cu = 63.55 u]

Options :

41652934806. $\frac{105}{x^3}$

41652934807. $\frac{211}{x^3}$

41652934808. $\frac{422}{x^3}$

41652934809. $\frac{205}{x^3}$

Question Number : 52 Question Id : 4165298837 Question Type : MCQ Option Shuffling : Yes Display Question Number : Yes
Single Line Question Option : No Option Orientation : Vertical

Correct Marks : 4 Wrong Marks : 1

100°C पर कापर (Cu), $x \text{ \AA}$ कोष्ठिका कोर की लम्बाई वाले FCC एकक कोष्ठिका संरचना रखता है। इस ताप पर Cu का घनत्व (g cm^{-3} में) लगभग होगा :

[Cu का परमाणु भार = 63.55 u]

Options :

41652934806. $\frac{105}{x^3}$

41652934807. $\frac{211}{x^3}$

41652934808. $\frac{422}{x^3}$

41652934809. $\frac{205}{x^3}$

Question Number : 53 Question Id : 4165298838 Question Type : MCQ Option Shuffling : Yes Display Question Number : Yes
Single Line Question Option : No Option Orientation : Vertical

Correct Marks : 4 Wrong Marks : 1

Which of the following combination of statements is true regarding the interpretation of the atomic orbitals ?

- (a) An electron in an orbital of high angular momentum stays away from the nucleus than an electron in the orbital of lower angular momentum.
- (b) For a given value of the principal quantum number, the size of the orbit is inversely proportional to the azimuthal quantum number.
- (c) According to wave mechanics, the ground state angular momentum is equal to $\frac{h}{2\pi}$.
- (d) The plot of ψ Vs r for various azimuthal quantum numbers, shows peak shifting towards higher r value.

Options :

41652934810. (a), (b)

41652934811. (a), (c)

41652934812. (b), (c)

41652934813. (a), (d)

Question Number : 53 Question Id : 4165298838 Question Type : MCQ Option Shuffling : Yes Display Question Number : Yes
Single Line Question Option : No Option Orientation : Vertical

Correct Marks : 4 Wrong Marks : 1

परमाणु कक्षकों की व्याख्या से संबंधित कौन से संयुक्त कथन सत्य है ?

- (a) कम कोणीय संवेग वाले कक्षक के इलेक्ट्रान की तुलना में अधिक कोणीय संवेग वाले कक्षक में इलेक्ट्रान नाभिक से दूर रहता है।
- (b) मुख्य क्वांटम संख्या के एक दिये मान के लिए कक्ष का आमाप विंगंशी क्वांटम संख्या के व्युत्क्रमानुपाती होता है।
- (c) तरंग यांत्रिकी के अनुसार निम्न अवस्था कोणीय संवेग $\frac{h}{2\pi}$ के बराबर होता है।
- (d) विभिन्न विंगंशी क्वांटम संख्याओं के लिए ψ Vs r का प्लॉट अधिक r मान की ओर पीक (शिखर) विस्थापित होना प्रदर्शित करता है।

Options :

41652934810. (a), (b)

41652934811. (a), (c)

41652934812. (b), (c)

41652934813. (a), (d)

Question Number : 54 Question Id : 4165298839 Question Type : MCQ Option Shuffling : Yes Display Question Number : Yes
Single Line Question Option : No Option Orientation : Vertical

Correct Marks : 4 Wrong Marks : 1

In which of the following processes, the bond order has increased and paramagnetic character has changed to diamagnetic ?

Options :

41652934814. $\text{NO} \rightarrow \text{NO}^+$

41652934815. $\text{O}_2 \rightarrow \text{O}_2^+$

41652934816. $\text{O}_2 \rightarrow \text{O}_2^{2-}$

41652934817. $\text{N}_2 \rightarrow \text{N}_2^+$

Question Number : 54 Question Id : 4165298839 Question Type : MCQ Option Shuffling : Yes Display Question Number : Yes
Single Line Question Option : No Option Orientation : Vertical

Correct Marks : 4 Wrong Marks : 1

नीचे दिए गए किस प्रक्रम में, आबंध कोटि बढ़ गयी और अनुचुंबकीय गुण प्रतिचुंबकीय में बदल गया ?

Options :

41652934814. $\text{NO} \rightarrow \text{NO}^+$

41652934815. $\text{O}_2 \rightarrow \text{O}_2^+$

41652934816. $\text{O}_2 \rightarrow \text{O}_2^{2-}$

41652934817. $\text{N}_2 \rightarrow \text{N}_2^+$

Question Number : 55 Question Id : 4165298840 Question Type : MCQ Option Shuffling : Yes Display Question Number : Yes
Single Line Question Option : No Option Orientation : Vertical

Correct Marks : 4 Wrong Marks : 1

The entropy change associated with the conversion of 1 kg of ice at 273 K to water vapours at 383 K is :

(Specific heat of water liquid and water vapour are $4.2 \text{ kJ K}^{-1} \text{ kg}^{-1}$ and $2.0 \text{ kJ K}^{-1} \text{ kg}^{-1}$; heat of liquid fusion and vapourisation of water are 334 kJ kg^{-1} and 2491 kJ kg^{-1} , respectively). ($\log 273 = 2.436$, $\log 373 = 2.572$, $\log 383 = 2.583$)

Options :

41652934818. $2.64 \text{ kJ kg}^{-1} \text{ K}^{-1}$

41652934819. $8.49 \text{ kJ kg}^{-1} \text{ K}^{-1}$

41652934820. $7.90 \text{ kJ kg}^{-1} \text{ K}^{-1}$

41652934821. $9.26 \text{ kJ kg}^{-1} \text{ K}^{-1}$

Question Number : 55 Question Id : 4165298840 Question Type : MCQ Option Shuffling : Yes Display Question Number : Yes
Single Line Question Option : No Option Orientation : Vertical

Correct Marks : 4 Wrong Marks : 1

273 K पर 1 kg बर्फ को 383 K के जल भाप में बदलने पर एंट्रॉपी में परिवर्तन होगा :

(जल तथा भाप की विशिष्ट ऊष्मा क्रमशः $4.2 \text{ kJ K}^{-1} \text{ kg}^{-1}$ एवं $2.0 \text{ kJ K}^{-1} \text{ kg}^{-1}$ हैं; संगलन की ऊष्मा तथा पानी की वाष्पीकरण ऊष्मा क्रमशः 334 kJ kg^{-1} एवं 2491 kJ kg^{-1} हैं) ($\log 273 = 2.436$, $\log 373 = 2.572$, $\log 383 = 2.583$)

Options :

41652934818. $2.64 \text{ kJ kg}^{-1} \text{ K}^{-1}$

41652934819. $8.49 \text{ kJ kg}^{-1} \text{ K}^{-1}$

41652934820. $7.90 \text{ kJ kg}^{-1} \text{ K}^{-1}$

41652934821. $9.26 \text{ kJ kg}^{-1} \text{ K}^{-1}$

Question Number : 56 Question Id : 4165298841 Question Type : MCQ Option Shuffling : Yes Display Question Number : Yes
Single Line Question Option : No Option Orientation : Vertical

Correct Marks : 4 Wrong Marks : 1

A solution containing 62 g ethylene glycol in 250 g water is cooled to -10°C . If K_f for water is $1.86 \text{ K kg mol}^{-1}$, the amount of water (in g) separated as ice is :

Options :

41652934822. 16

41652934823. 32

41652934824. 48

41652934825. 64

Question Number : 56 Question Id : 4165298841 Question Type : MCQ Option Shuffling : Yes Display Question Number : Yes
Single Line Question Option : No Option Orientation : Vertical

Correct Marks : 4 Wrong Marks : 1

एक विलयन जिसमें 62 g इथिलीन ग्लाइकॉल 250 g पानी में है, को -10°C तक ठंडा किया गया। यदि पानी का K_f $1.86 \text{ K kg mol}^{-1}$ हो, तब बर्फ के रूप में अलग हुए पानी की मात्रा (g में) है :

Options :

41652934822. 16

41652934823. 32

41652934824. 48

41652934825. 64

Question Number : 57 Question Id : 4165298842 Question Type : MCQ Option Shuffling : Yes Display Question Number : Yes
Single Line Question Option : No Option Orientation : Vertical

Correct Marks : 4 Wrong Marks : 1

Consider the following reversible chemical reactions :

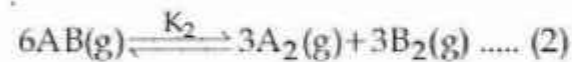
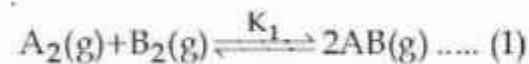

The relation between K_1 and K_2 is :

Options :

41652934826. $K_2 = K_1^{-3}$

41652934827. $K_2 = K_1^3$

41652934828. $K_1 K_2 = 3$

$$K_1 K_2 = \frac{1}{3}$$

41652934829.

Question Number : 57 Question Id : 4165298842 Question Type : MCQ Option Shuffling : Yes Display Question Number : Yes
Single Line Question Option : No Option Orientation : Vertical

Correct Marks : 4 Wrong Marks : 1

निम्न उत्क्रमणीय अभिक्रियाओं पर विचार करें :

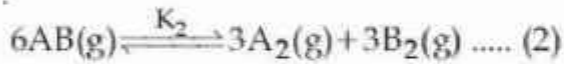
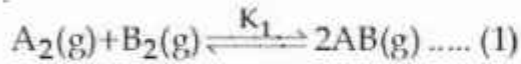

K_1 एवं K_2 के बीच संबंध है :

Options :

41652934826. $K_2 = K_1^{-3}$

41652934827. $K_2 = K_1^3$

41652934828. $K_1 K_2 = 3$

41652934829. $K_1 K_2 = \frac{1}{3}$

Question Number : 58 Question Id : 4165298843 Question Type : MCQ Option Shuffling : Yes Display Question Number : Yes
Single Line Question Option : No Option Orientation : Vertical

Correct Marks : 4 Wrong Marks : 1

If the standard electrode potential for a cell is 2 V at 300 K, the equilibrium constant (K) for the reaction



at 300 K is approximately

($R = 8 \text{ JK}^{-1} \text{ mol}^{-1}$, $F = 96000 \text{ C mol}^{-1}$)

Options :

41652934830. e^{-80}

41652934831. e^{320}

41652934832. e^{-160}

41652934833. e^{160}

Question Number : 58 Question Id : 4165298843 Question Type : MCQ Option Shuffling : Yes Display Question Number : Yes
Single Line Question Option : No Option Orientation : Vertical

Correct Marks : 4 Wrong Marks : 1

एक सेल का 300 K पर मानक इलेक्ट्रोड विभव 2 V है। अभिक्रिया

$\text{Zn(s)} + \text{Cu}^{2+}(\text{aq}) \rightleftharpoons \text{Zn}^{2+}(\text{aq}) + \text{Cu(s)}$ के लिए 300 K ताप पर साम्यावस्था स्थिरांक (K) लगभग है :

($R = 8 \text{ JK}^{-1}\text{mol}^{-1}$, $F = 96000 \text{ C mol}^{-1}$)

Options :

41652934830. e^{-80}

41652934831. e^{320}

41652934832. e^{-160}

41652934833. e^{160}

Question Number : 59 Question Id : 4165298844 Question Type : MCQ Option Shuffling : Yes Display Question Number : Yes Single Line Question Option : No Option Orientation : Vertical

Correct Marks : 4 Wrong Marks : 1

For the reaction, $2\text{A} + \text{B} \rightarrow \text{products}$, when the concentrations of A and B both were doubled, the rate of the reaction increased from $0.3 \text{ mol L}^{-1}\text{s}^{-1}$ to $2.4 \text{ mol L}^{-1}\text{s}^{-1}$. When the concentration of A alone is doubled, the rate increased from $0.3 \text{ mol L}^{-1}\text{s}^{-1}$ to $0.6 \text{ mol L}^{-1}\text{s}^{-1}$.

Which one of the following statements is correct ?

Options :

41652934834. Order of the reaction with respect to B is 2

41652934835. Total order of the reaction is 4

41652934836. Order of the reaction with respect to A is 2

41652934837. Order of the reaction with respect to B is 1

Question Number : 59 Question Id : 4165298844 Question Type : MCQ Option Shuffling : Yes Display Question Number : Yes Single Line Question Option : No Option Orientation : Vertical

Correct Marks : 4 Wrong Marks : 1

अभिक्रिया, $2A + B \rightarrow \text{products}$ के लिए, जब A तथा B दोनों की सांद्रता दोगुनी की गई, तब अभिक्रिया की दर $0.3 \text{ mol L}^{-1}\text{s}^{-1}$ से बढ़कर $2.4 \text{ mol L}^{-1}\text{s}^{-1}$ हो गयी। जब केवल A की सांद्रता दोगुनी की गई तब दर $0.3 \text{ mol L}^{-1}\text{s}^{-1}$ से बढ़कर $0.6 \text{ mol L}^{-1}\text{s}^{-1}$ हो गई।

निम्न में कौन सा कथन सत्य है?

Options :

41652934834. अभिक्रिया की कोटि B के सापेक्ष में 2 है।

41652934835. कुल अभिक्रिया की कोटि 4 है।

41652934836. अभिक्रिया की कोटि A के सापेक्ष में 2 है।

41652934837. अभिक्रिया की कोटि B के सापेक्ष में 1 है।

Question Number : 60 Question Id : 4165298845 Question Type : MCQ Option Shuffling : Yes Display Question Number : Yes
Single Line Question Option : No Option Orientation : Vertical

Correct Marks : 4 Wrong Marks : 1

For coagulation of arsenious sulphide sol, which one of the following salt solution will be most effective ?

Options :

41652934838. AlCl_3

41652934839. BaCl_2

41652934840. NaCl

41652934841. Na_3PO_4

Question Number : 60 Question Id : 4165298845 Question Type : MCQ Option Shuffling : Yes Display Question Number : Yes
Single Line Question Option : No Option Orientation : Vertical

Correct Marks : 4 Wrong Marks : 1

आर्सेनियस सल्फाइड का स्कंदन निम्न में से किस लवण के घोल से सबसे अधिक प्रभावकारी होगा ?

Options :

41652934838. AlCl_3

41652934839. BaCl_2

41652934840. NaCl

41652934841. Na₃PO₄

Mathematics

Section Id :	416529117
Section Number :	3
Section type :	Online
Mandatory or Optional:	Mandatory
Number of Questions:	30
Number of Questions to be attempted:	30
Section Marks:	120
Display Number Panel:	Yes
Group All Questions:	No

Sub-Section Number:	1
Sub-Section Id:	416529126
Question Shuffling Allowed :	Yes

Question Number : 61 Question Id : 4165298846 Question Type : MCQ Option Shuffling : Yes Display Question Number : Yes
Single Line Question Option : No Option Orientation : Vertical
Correct Marks : 4 Wrong Marks : 1

Let $A = \{x \in \mathbb{R} : x \text{ is not a positive integer}\}$.

Define a function $f: A \rightarrow \mathbb{R}$ as $f(x) = \frac{2x}{x-1}$,

then f is :

Options :

41652934842. not injective

41652934843. injective but not surjective

41652934844. surjective but not injective

41652934845. neither injective nor surjective

Question Number : 61 Question Id : 4165298846 Question Type : MCQ Option Shuffling : Yes Display Question Number : Yes
Single Line Question Option : No Option Orientation : Vertical
Correct Marks : 4 Wrong Marks : 1

माना $A = \{x \in \mathbb{R} : x \text{ एक धन पूर्णांक नहीं है}\}$ । एक
फलन $f: A \rightarrow \mathbb{R}$ निम्न प्रकार से परिभाषित है :

$f(x) = \frac{2x}{x-1}$, तो f एक :

Options :

41652934842. एकैकी फलन नहीं है।

41652934843. एकैकी है, परन्तु आच्छादक फलन नहीं है।

41652934844. आच्छादक है, परन्तु एकैकी फलन नहीं है।

41652934845. न एकैकी है और न आच्छादक फलन है।

Question Number : 62 Question Id : 4165298847 Question Type : MCQ Option Shuffling : Yes Display Question Number : Yes
Single Line Question Option : No Option Orientation : Vertical

Correct Marks : 4 Wrong Marks : 1

Let z_0 be a root of the quadratic equation,

$x^2 + x + 1 = 0$. If $z = 3 + 6iz_0^{81} - 3iz_0^{93}$, then

$\arg z$ is equal to :

Options :

41652934846. $\frac{\pi}{4}$

41652934847. $\frac{\pi}{6}$

41652934848. $\frac{\pi}{3}$

41652934849. 0

Question Number : 62 Question Id : 4165298847 Question Type : MCQ Option Shuffling : Yes Display Question Number : Yes
Single Line Question Option : No Option Orientation : Vertical

Correct Marks : 4 Wrong Marks : 1

माना कि द्विघातीय समीकरण $x^2 + x + 1 = 0$, का एक

मूल z_0 है। यदि $z = 3 + 6iz_0^{81} - 3iz_0^{93}$ है, तो

कोणांक z ($\arg z$) बराबर है :

Options :

41652934846. $\frac{\pi}{4}$

41652934847. $\frac{\pi}{6}$

41652934848. $\frac{\pi}{3}$

41652934849. 0

Question Number : 63 Question Id : 4165298848 Question Type : MCQ Option Shuffling : Yes Display Question Number : Yes
Single Line Question Option : No Option Orientation : Vertical

Correct Marks : 4 Wrong Marks : 1

The number of all possible positive integral values of α for which the roots of the quadratic equation, $6x^2 - 11x + \alpha = 0$ are rational numbers is :

Options :

41652934850. 2

41652934851. 3

41652934852. 4

41652934853. 5

Question Number : 63 Question Id : 4165298848 Question Type : MCQ Option Shuffling : Yes Display Question Number : Yes
Single Line Question Option : No Option Orientation : Vertical

Correct Marks : 4 Wrong Marks : 1

α के उन सभी संभावित धन पूर्णांक मानों की संख्या जिनके लिए द्विघातीय समीकरण $6x^2 - 11x + \alpha = 0$ के मूल परिमेय संख्याएँ हैं, हैं :

Options :

41652934850. 2

41652934851. 3

41652934852. 4

41652934853. 5

Question Number : 64 Question Id : 4165298849 Question Type : MCQ Option Shuffling : Yes Display Question Number : Yes
Single Line Question Option : No Option Orientation : Vertical

Correct Marks : 4 Wrong Marks : 1

If

$$A = \begin{bmatrix} e^t & e^{-t} \cos t & e^{-t} \sin t \\ e^t & -e^{-t} \cos t - e^{-t} \sin t & -e^{-t} \sin t + e^{-t} \cos t \\ e^t & 2e^{-t} \sin t & -2e^{-t} \cos t \end{bmatrix},$$

then A is :

Options :

invertible only if $t = \pi$.

41652934854.

invertible only if $t = \frac{\pi}{2}$.

41652934855.

invertible for all $t \in \mathbb{R}$.

41652934856.

not invertible for any $t \in \mathbb{R}$.

41652934857.

Question Number : 64 Question Id : 4165298849 Question Type : MCQ Option Shuffling : Yes Display Question Number : Yes
Single Line Question Option : No Option Orientation : Vertical

Correct Marks : 4 Wrong Marks : 1

यदि

$$A = \begin{bmatrix} e^t & e^{-t} \cos t & e^{-t} \sin t \\ e^t & -e^{-t} \cos t - e^{-t} \sin t & -e^{-t} \sin t + e^{-t} \cos t \\ e^t & 2e^{-t} \sin t & -2e^{-t} \cos t \end{bmatrix}$$

है, तो A :

Options :

व्युत्क्रमणीय (invertible) है, केवल तब, जब

41652934854. $t = \pi$ है।

व्युत्क्रमणीय है, केवल तब, जब $t = \frac{\pi}{2}$ है।

41652934855.

सभी $t \in \mathbb{R}$ के लिए व्युत्क्रमणीय है।

41652934856.

किसी भी $t \in \mathbb{R}$ के लिए व्युत्क्रमणीय नहीं है।

41652934857.

Question Number : 65 Question Id : 4165298850 Question Type : MCQ Option Shuffling : Yes Display Question Number : Yes
Single Line Question Option : No Option Orientation : Vertical

Correct Marks : 4 Wrong Marks : 1

If the system of linear equations

$$x - 4y + 7z = g$$

$$3y - 5z = h$$

$$-2x + 5y - 9z = k$$

is consistent, then :

Options :

41652934858. $2g + h + k = 0$

41652934859. $g + 2h + k = 0$

41652934860. $g + h + 2k = 0$

41652934861. $g + h + k = 0$

Question Number : 65 Question Id : 4165298850 Question Type : MCQ Option Shuffling : Yes Display Question Number : Yes
Single Line Question Option : No Option Orientation : Vertical

Correct Marks : 4 Wrong Marks : 1

यदि रेखिक समीकरण निकाय

$$x - 4y + 7z = g$$

$$3y - 5z = h$$

$$-2x + 5y - 9z = k$$

संगत (consistent) हैं, तो :

Options :

41652934858. $2g + h + k = 0$

41652934859. $g + 2h + k = 0$

41652934860. $g + h + 2k = 0$

41652934861. $g + h + k = 0$

Question Number : 66 Question Id : 4165298851 Question Type : MCQ Option Shuffling : Yes Display Question Number : Yes
Single Line Question Option : No Option Orientation : Vertical

Correct Marks : 4 Wrong Marks : 1

The number of natural numbers less than 7,000 which can be formed by using the digits 0, 1, 3, 7, 9 (repetition of digits allowed) is equal to :

Options :

41652934862. 372

41652934863. 375

41652934864. 374

41652934865. 250

Question Number : 66 Question Id : 4165298851 Question Type : MCQ Option Shuffling : Yes Display Question Number : Yes
Single Line Question Option : No Option Orientation : Vertical

Correct Marks : 4 Wrong Marks : 1

अंकों 0, 1, 3, 7, 9 के प्रयोग से (जहाँ अंकों को दोहराया जा सकता है) बनाई जा सकने वाली प्राकृत संख्याएँ जो 7,000 से कम हैं, की संख्या है :

Options :

41652934862. 372

41652934863. 375

41652934864. 374

41652934865. 250

Question Number : 67 Question Id : 4165298852 Question Type : MCQ Option Shuffling : Yes Display Question Number : Yes
Single Line Question Option : No Option Orientation : Vertical

Correct Marks : 4 Wrong Marks : 1

The coefficient of t^4 in the expansion of

$$\left(\frac{1-t^6}{1-t}\right)^3 \text{ is :}$$

Options :

41652934866. 12

41652934867. 10

41652934868. 15

41652934869. 14

Question Number : 67 Question Id : 4165298852 Question Type : MCQ Option Shuffling : Yes Display Question Number : Yes
Single Line Question Option : No Option Orientation : Vertical

Correct Marks : 4 Wrong Marks : 1

$$\left(\frac{1-t^6}{1-t}\right)^3 \text{ के प्रसार में } t^4 \text{ का गुणांक है :}$$

Options :

41652934866. 12

41652934867. 10

41652934868. 15

41652934869. 14

Question Number : 68 Question Id : 4165298853 Question Type : MCQ Option Shuffling : Yes Display Question Number : Yes
Single Line Question Option : No Option Orientation : Vertical

Correct Marks : 4 Wrong Marks : 1

Let a, b and c be the 7th, 11th and 13th terms respectively of a non-constant A.P. If these are also the three consecutive terms of a

G.P., then $\frac{a}{c}$ is equal to :

Options :

41652934870. 4

41652934871. 2

41652934872. $\frac{7}{13}$

41652934873. $\frac{1}{2}$

Question Number : 68 Question Id : 4165298853 Question Type : MCQ Option Shuffling : Yes Display Question Number : Yes
Single Line Question Option : No Option Orientation : Vertical

Correct Marks : 4 Wrong Marks : 1

माना a, b तथा c एक समांतर श्रेणी (जो कि अचर समांतर श्रेणी नहीं है) के क्रमशः 7^{वें}, 11^{वें} तथा 13^{वें} पद हैं। यदि ये एक गुणोत्तर श्रेणी के भी तीन क्रमागत

पद हैं तो $\frac{a}{c}$ बराबर है :

Options :

41652934870. 4

41652934871. 2

41652934872. $\frac{7}{13}$

41652934873. $\frac{1}{2}$

Question Number : 69 Question Id : 4165298854 Question Type : MCQ Option Shuffling : Yes Display Question Number : Yes
Single Line Question Option : No Option Orientation : Vertical

Correct Marks : 4 Wrong Marks : 1

The sum of the following series

$$1+6+\frac{9(1^2+2^2+3^2)}{7}+\frac{12(1^2+2^2+3^2+4^2)}{9} \\ +\frac{15(1^2+2^2+\dots+5^2)}{11}+\dots \text{ up to 15 terms,}$$

is :

Options :

41652934874. 7510

41652934875. 7820

41652934876. 7830

41652934877. 7520

Question Number : 69 Question Id : 4165298854 Question Type : MCQ Option Shuffling : Yes Display Question Number : Yes
Single Line Question Option : No Option Orientation : Vertical

Correct Marks : 4 Wrong Marks : 1

निम्न श्रेणी

$$1+6+\frac{9(1^2+2^2+3^2)}{7}+\frac{12(1^2+2^2+3^2+4^2)}{9} \\ +\frac{15(1^2+2^2+\dots+5^2)}{11}+\dots \text{ के प्रथम 15 पदों का}$$

योग है :

Options :

41652934874. 7510

41652934875. 7820

41652934876. 7830

41652934877. 7520

Question Number : 70 Question Id : 4165298855 Question Type : MCQ Option Shuffling : Yes Display Question Number : Yes
Single Line Question Option : No Option Orientation : Vertical

Correct Marks : 4 Wrong Marks : 1

For each $x \in \mathbb{R}$, let $[x]$ be the greatest integer less than or equal to x . Then

$$\lim_{x \rightarrow 0^-} \frac{x([x]+|x|) \sin [x]}{|x|} \text{ is equal to :}$$

Options :

41652934878. $\sin 1$

41652934879. 0

41652934880. $-\sin 1$

41652934881. 1

Question Number : 70 Question Id : 4165298855 Question Type : MCQ Option Shuffling : Yes Display Question Number : Yes
Single Line Question Option : No Option Orientation : Vertical

Correct Marks : 4 Wrong Marks : 1

सभी $x \in \mathbb{R}$ के लिए, माना $[x]$, एक महत्तम पूर्णांक है जो x के समान अथवा उससे कम है, तो

$\lim_{x \rightarrow 0^-} \frac{x([x] + |x|) \sin [x]}{|x|}$ बराबर है :

Options :

41652934878. $\sin 1$

41652934879. 0

41652934880. $-\sin 1$

41652934881. 1

Question Number : 71 Question Id : 4165298856 Question Type : MCQ Option Shuffling : Yes Display Question Number : Yes
Single Line Question Option : No Option Orientation : Vertical

Correct Marks : 4 Wrong Marks : 1

If $x = 3 \tan t$ and $y = 3 \sec t$, then the value

of $\frac{d^2 y}{dx^2}$ at $t = \frac{\pi}{4}$, is :

Options :

41652934882. $\frac{1}{6}$

41652934883. $\frac{1}{6\sqrt{2}}$

41652934884. $\frac{1}{3\sqrt{2}}$

41652934885. $\frac{3}{2\sqrt{2}}$

Question Number : 71 Question Id : 4165298856 Question Type : MCQ Option Shuffling : Yes Display Question Number : Yes
Single Line Question Option : No Option Orientation : Vertical

Correct Marks : 4 Wrong Marks : 1

यदि $x = 3 \tan t$ तथा $y = 3 \sec t$ है, तो $t = \frac{\pi}{4}$ पर

$\frac{d^2 y}{dx^2}$ का मान है :

Options :

41652934882. $\frac{1}{6}$

41652934883. $\frac{1}{6\sqrt{2}}$

41652934884. $\frac{1}{3\sqrt{2}}$

41652934885. $\frac{3}{2\sqrt{2}}$

Question Number : 72 Question Id : 4165298857 Question Type : MCQ Option Shuffling : Yes Display Question Number : Yes
Single Line Question Option : No Option Orientation : Vertical

Correct Marks : 4 Wrong Marks : 1

If both the roots of the quadratic equation $x^2 - mx + 4 = 0$ are real and distinct and they lie in the interval $[1, 5]$, then m lies in the interval :

Options :

41652934886. $(-5, -4)$

41652934887. $(3, 4)$

41652934888. $(4, 5)$

41652934889. $(5, 6)$

Question Number : 72 Question Id : 4165298857 Question Type : MCQ Option Shuffling : Yes Display Question Number : Yes
Single Line Question Option : No Option Orientation : Vertical

Correct Marks : 4 Wrong Marks : 1

यदि द्विघात समीकरण $x^2 - mx + 4 = 0$ के दोनों मूल वास्तविक तथा भिन्न हैं और वे अंतराल $[1, 5]$ में स्थित हैं, तो m जिस अंतराल में स्थित है, वह है :

Options :

41652934886. $(-5, -4)$

41652934887. $(3, 4)$

41652934888. $(4, 5)$

41652934889. $(5, 6)$

Question Number : 73 Question Id : 4165298858 Question Type : MCQ Option Shuffling : Yes Display Question Number : Yes
Single Line Question Option : No Option Orientation : Vertical

Correct Marks : 4 Wrong Marks : 1

Let f be a differentiable function from

\mathbb{R} to \mathbb{R} such that $|f(x) - f(y)| \leq 2|x - y|^{3/2}$, for

all $x, y \in \mathbb{R}$. If $f(0) = 1$ then $\int_0^1 f^2(x) dx$ is

equal to :

Options :

41652934890. 0

41652934891. 1

41652934892. $\frac{1}{2}$

41652934893. 2

Question Number : 73 Question Id : 4165298858 Question Type : MCQ Option Shuffling : Yes Display Question Number : Yes
Single Line Question Option : No Option Orientation : Vertical

Correct Marks : 4 Wrong Marks : 1

माना $f: \mathbb{R} \rightarrow \mathbb{R}$ एक ऐसा अवकलनीय फलन है, कि

सभी $x, y \in \mathbb{R}$ के लिए $|f(x) - f(y)| \leq 2|x - y|^{3/2}$

है। यदि $f(0) = 1$ है, तो $\int_0^1 f^2(x) dx$ बराबर है :

Options :

41652934890. 0

41652934891. 1

41652934892. $\frac{1}{2}$

41652934893. 2

Question Number : 74 Question Id : 4165298859 Question Type : MCQ Option Shuffling : Yes Display Question Number : Yes
Single Line Question Option : No Option Orientation : Vertical

Correct Marks : 4 Wrong Marks : 1

If $f(x) = \int \frac{5x^8 + 7x^6}{(x^2 + 1 + 2x^7)^2} dx, (x \geq 0)$, and

$f(0) = 0$, then the value of $f(1)$ is :

Options :

41652934894. $-\frac{1}{2}$

41652934895. $\frac{1}{4}$

41652934896. $\frac{1}{2}$

41652934897. $-\frac{1}{4}$

Question Number : 74 Question Id : 4165298859 Question Type : MCQ Option Shuffling : Yes Display Question Number : Yes
Single Line Question Option : No Option Orientation : Vertical

Correct Marks : 4 Wrong Marks : 1

यदि $f(x) = \int \frac{5x^8 + 7x^6}{(x^2 + 1 + 2x^7)^2} dx, (x \geq 0)$ तथा

$f(0) = 0$ है, तो $f(1)$ का मान है :

Options :

41652934894. $-\frac{1}{2}$

41652934895. $\frac{1}{4}$

41652934896. $\frac{1}{2}$

41652934897. $-\frac{1}{4}$

Question Number : 75 Question Id : 4165298860 Question Type : MCQ Option Shuffling : Yes Display Question Number : Yes
Single Line Question Option : No Option Orientation : Vertical
Correct Marks : 4 Wrong Marks : 1

If $\int_0^{\pi/3} \frac{\tan \theta}{\sqrt{2k \sec \theta}} d\theta = 1 - \frac{1}{\sqrt{2}}$, ($k > 0$), then the

value of k is :

Options :

41652934898. 2

41652934899. 1

41652934900. 4

41652934901. $\frac{1}{2}$

Question Number : 75 Question Id : 4165298860 Question Type : MCQ Option Shuffling : Yes Display Question Number : Yes
Single Line Question Option : No Option Orientation : Vertical
Correct Marks : 4 Wrong Marks : 1

यदि $\int_0^{\pi/3} \frac{\tan \theta}{\sqrt{2k \sec \theta}} d\theta = 1 - \frac{1}{\sqrt{2}}$, ($k > 0$) है, तो k

का मान है :

Options :

41652934898. 2

41652934899. 1

41652934900. 4

41652934901. $\frac{1}{2}$

Question Number : 76 Question Id : 4165298861 Question Type : MCQ Option Shuffling : Yes Display Question Number : Yes
Single Line Question Option : No Option Orientation : Vertical
Correct Marks : 4 Wrong Marks : 1

The area of the region

$A = \{(x, y) : 0 \leq y \leq x|x| + 1 \text{ and } -1 \leq x \leq 1\}$ in sq. units, is :

Options :

$$\frac{2}{3}$$

41652934902.

$$\frac{1}{3}$$

41652934903.

$$\frac{4}{3}$$

41652934904.

$$2$$

41652934905.

Question Number : 76 Question Id : 4165298861 Question Type : MCQ Option Shuffling : Yes Display Question Number : Yes
Single Line Question Option : No Option Orientation : Vertical

Correct Marks : 4 Wrong Marks : 1

क्षेत्र $A = \{(x, y) : 0 \leq y \leq x|x| + 1 \text{ तथा } -1 \leq x \leq 1\}$

का वर्ग इकाईयों में क्षेत्रफल है :

Options :

$$\frac{2}{3}$$

41652934902.

$$\frac{1}{3}$$

41652934903.

$$\frac{4}{3}$$

41652934904.

$$2$$

41652934905.

Question Number : 77 Question Id : 4165298862 Question Type : MCQ Option Shuffling : Yes Display Question Number : Yes
Single Line Question Option : No Option Orientation : Vertical

Correct Marks : 4 Wrong Marks : 1

Let $f: [0, 1] \rightarrow \mathbf{R}$ be such that $f(xy) = f(x)f(y)$, for all $x, y \in [0, 1]$, and $f(0) \neq 0$. If $y = y(x)$ satisfies the differential equation,

$\frac{dy}{dx} = f(x)$ with $y(0) = 1$, then $y\left(\frac{1}{4}\right) + y\left(\frac{3}{4}\right)$

is equal to :

Options :

$$2$$

41652934906.

41652934907. 3

41652934908. 4

41652934909. 5

Question Number : 77 Question Id : 4165298862 Question Type : MCQ Option Shuffling : Yes Display Question Number : Yes
Single Line Question Option : No Option Orientation : Vertical

Correct Marks : 4 Wrong Marks : 1

माना $f : [0, 1] \rightarrow \mathbb{R}$ इस प्रकार है कि सभी $x, y \in [0, 1]$ के लिए $f(xy) = f(x) \cdot f(y)$ है तथा $f(0) \neq 0$

है। यदि $y = y(x)$ अवकल समीकरण $\frac{dy}{dx} = f(x)$

को संतुष्ट करता है और $y(0) = 1$ है, तो

$y\left(\frac{1}{4}\right) + y\left(\frac{3}{4}\right)$ बराबर है :

Options :

41652934906. 2

41652934907. 3

41652934908. 4

41652934909. 5

Question Number : 78 Question Id : 4165298863 Question Type : MCQ Option Shuffling : Yes Display Question Number : Yes
Single Line Question Option : No Option Orientation : Vertical

Correct Marks : 4 Wrong Marks : 1

Let S be the set of all triangles in the xy -plane, each having one vertex at the origin and the other two vertices lie on coordinate axes with integral coordinates. If each triangle in S has area 50 sq. units, then the number of elements in the set S is :

Options :

41652934910. 9

41652934911. 18

41652934912. 36

41652934913. 32

Question Number : 78 Question Id : 4165298863 Question Type : MCQ Option Shuffling : Yes Display Question Number : Yes
Single Line Question Option : No Option Orientation : Vertical

Correct Marks : 4 Wrong Marks : 1

माना S, xy -तल में स्थित ऐसी सभी त्रिभुजों का समुच्चय है जिनका एक शीर्ष मूल बिंदु पर है तथा दूसरे दो शीर्ष निर्देशांक अक्षों पर हैं तथा जिनके निर्देशांक पूर्णांकिय हैं। यदि S की प्रत्येक त्रिभुज का क्षेत्रफल 50 वर्ग इकाई है, तो समुच्चय S के अवयवों की संख्या है :

Options :

41652934910. 9

41652934911. 18

41652934912. 36

41652934913. 32

Question Number : 79 Question Id : 4165298864 Question Type : MCQ Option Shuffling : Yes Display Question Number : Yes
Single Line Question Option : No Option Orientation : Vertical

Correct Marks : 4 Wrong Marks : 1

Let the equations of two sides of a triangle be $3x - 2y + 6 = 0$ and $4x + 5y - 20 = 0$. If the orthocentre of this triangle is at $(1, 1)$, then the equation of its third side is :

Options :

41652934914. $122y - 26x - 1675 = 0$

41652934915. $26x - 122y - 1675 = 0$

41652934916. $26x + 61y + 1675 = 0$

41652934917. $122y + 26x + 1675 = 0$

Question Number : 79 Question Id : 4165298864 Question Type : MCQ Option Shuffling : Yes Display Question Number : Yes
Single Line Question Option : No Option Orientation : Vertical

Correct Marks : 4 Wrong Marks : 1

माना एक त्रिभुज की दो भुजाओं के समीकरण $3x - 2y + 6 = 0$ तथा $4x + 5y - 20 = 0$ हैं। यदि इस त्रिभुज का लंबकेंद्र $(1, 1)$ पर है, तो इसकी तीसरी भुजा का समीकरण है :

Options :

41652934914. $122y - 26x - 1675 = 0$

41652934915. $26x - 122y - 1675 = 0$

41652934916. $26x + 61y + 1675 = 0$

41652934917. $122y + 26x + 1675 = 0$

Question Number : 80 Question Id : 4165298865 Question Type : MCQ Option Shuffling : Yes Display Question Number : Yes
Single Line Question Option : No Option Orientation : Vertical

Correct Marks : 4 Wrong Marks : 1

If the circles $x^2 + y^2 - 16x - 20y + 164 = r^2$
and $(x - 4)^2 + (y - 7)^2 = 36$ intersect at two
distinct points, then :

Options :

41652934918. $1 < r < 11$

41652934919. $0 < r < 1$

41652934920. $r = 11$

41652934921. $r > 11$

Question Number : 80 Question Id : 4165298865 Question Type : MCQ Option Shuffling : Yes Display Question Number : Yes
Single Line Question Option : No Option Orientation : Vertical

Correct Marks : 4 Wrong Marks : 1

यदि वृत्त $x^2 + y^2 - 16x - 20y + 164 = r^2$ तथा
 $(x - 4)^2 + (y - 7)^2 = 36$, दो भिन्न बिंदुओं पर काटते
हैं, तो :

Options :

41652934918. $1 < r < 11$

41652934919. $0 < r < 1$

41652934920. $r = 11$

41652934921. $r > 11$

Question Number : 81 Question Id : 4165298866 Question Type : MCQ Option Shuffling : Yes Display Question Number : Yes
Single Line Question Option : No Option Orientation : Vertical

Correct Marks : 4 Wrong Marks : 1

Let A(4, -4) and B(9, 6) be points on the parabola, $y^2=4x$. Let C be chosen on the arc AOB of the parabola, where O is the origin, such that the area of ΔACB is maximum. Then, the area (in sq.units) of ΔACB , is :

Options :

$$31\frac{1}{4}$$

41652934922.

$$30\frac{1}{2}$$

41652934923.

$$32$$

41652934924.

$$31\frac{3}{4}$$

41652934925.

Question Number : 81 Question Id : 4165298866 Question Type : MCQ Option Shuffling : Yes Display Question Number : Yes
Single Line Question Option : No Option Orientation : Vertical

Correct Marks : 4 Wrong Marks : 1

माना A(4, -4) तथा B(9, 6) एक परवलय $y^2=4x$ पर स्थित दो बिंदु हैं। माना परवलय के चाप AOB (जहाँ O मूल बिंदु है) पर स्थित एक बिंदु C इस प्रकार चुना गया कि ΔACB का क्षेत्रफल अधिकतम है, तो ΔACB का क्षेत्रफल (वर्ग इकाईयों में) है :

Options :

$$31\frac{1}{4}$$

41652934922.

$$30\frac{1}{2}$$

41652934923.

$$32$$

41652934924.

$$31\frac{3}{4}$$

41652934925.

Question Number : 82 Question Id : 4165298867 Question Type : MCQ Option Shuffling : Yes Display Question Number : Yes
Single Line Question Option : No Option Orientation : Vertical

Correct Marks : 4 Wrong Marks : 1

A hyperbola has its centre at the origin, passes through the point (4, 2) and has transverse axis of length 4 along the x-axis.

Then the eccentricity of the hyperbola is :

Options :

41652934926. $\sqrt{3}$

41652934927. $\frac{2}{\sqrt{3}}$

41652934928. 2

41652934929. $\frac{3}{2}$

Question Number : 82 Question Id : 4165298867 Question Type : MCQ Option Shuffling : Yes Display Question Number : Yes
Single Line Question Option : No Option Orientation : Vertical

Correct Marks : 4 Wrong Marks : 1

एक अतिपरवलय का केंद्र मूल बिंदु पर है, तथा यह बिंदु (4, 2) से होकर जाता है और इसका अनुप्रस्थ (transverse) अक्ष, x-अक्ष के अनुदिश है जिसकी लंबाई 4 है। तो इस अतिपरवलय की उत्केंद्रता (eccentricity) है :

Options :

41652934926. $\sqrt{3}$

41652934927. $\frac{2}{\sqrt{3}}$

41652934928. 2

41652934929. $\frac{3}{2}$

Question Number : 83 Question Id : 4165298868 Question Type : MCQ Option Shuffling : Yes Display Question Number : Yes
Single Line Question Option : No Option Orientation : Vertical

Correct Marks : 4 Wrong Marks : 1

If the lines $x = ay + b$, $z = cy + d$ and $x = a'z + b'$, $y = c'z + d'$ are perpendicular, then :

Options :

41652934930. $ab' + bc' + 1 = 0$

41652934931. $bb' + cc' + 1 = 0$

41652934932. $aa' + c + c' = 0$

41652934933. $cc' + a + a' = 0$

Question Number : 83 Question Id : 4165298868 Question Type : MCQ Option Shuffling : Yes Display Question Number : Yes
Single Line Question Option : No Option Orientation : Vertical

Correct Marks : 4 Wrong Marks : 1

यदि रेखाएँ $x = ay + b, z = cy + d$ तथा $x = a'z + b',$
 $y = c'z + d'$ लंबवत हैं, तो :

Options :

41652934930. $ab' + bc' + 1 = 0$

41652934931. $bb' + cc' + 1 = 0$

41652934932. $aa' + c + c' = 0$

41652934933. $cc' + a + a' = 0$

Question Number : 84 Question Id : 4165298869 Question Type : MCQ Option Shuffling : Yes Display Question Number : Yes
Single Line Question Option : No Option Orientation : Vertical

Correct Marks : 4 Wrong Marks : 1

The equation of the plane containing the

straight line $\frac{x}{2} = \frac{y}{3} = \frac{z}{4}$ and perpendicular
to the plane containing the straight lines

$$\frac{x}{3} = \frac{y}{4} = \frac{z}{2} \text{ and } \frac{x}{4} = \frac{y}{2} = \frac{z}{3} \text{ is :}$$

Options :

41652934934. $x + 2y - 2z = 0$

41652934935. $3x + 2y - 3z = 0$

41652934936. $x - 2y + z = 0$

41652934937. $5x + 2y - 4z = 0$

Question Number : 84 Question Id : 4165298869 Question Type : MCQ Option Shuffling : Yes Display Question Number : Yes
Single Line Question Option : No Option Orientation : Vertical

Correct Marks : 4 Wrong Marks : 1

एक ऐसे समतल का समीकरण, जिस पर रेखा

$$\frac{x}{2} = \frac{y}{3} = \frac{z}{4} \text{ स्थित है तथा जो एक अन्य समतल}$$

$$\text{जिसमें रेखाएँ } \frac{x}{3} = \frac{y}{4} = \frac{z}{2} \text{ तथा } \frac{x}{4} = \frac{y}{2} = \frac{z}{3} \text{ स्थित}$$

हैं, के लंबवत है, है :

Options :

41652934934. $x + 2y - 2z = 0$

41652934935. $3x + 2y - 3z = 0$

41652934936. $x - 2y + z = 0$

41652934937. $5x + 2y - 4z = 0$

Question Number : 85 Question Id : 4165298870 Question Type : MCQ Option Shuffling : Yes Display Question Number : Yes
Single Line Question Option : No Option Orientation : Vertical

Correct Marks : 4 Wrong Marks : 1

$$\text{Let } \vec{a} = \hat{i} + \hat{j} + \sqrt{2}\hat{k}, \vec{b} = b_1\hat{i} + b_2\hat{j} + \sqrt{2}\hat{k}$$

and $\vec{c} = 5\hat{i} + \hat{j} + \sqrt{2}\hat{k}$ be three vectors such

that the projection vector of \vec{b} on \vec{a} is \vec{a} .

If $\vec{a} + \vec{b}$ is perpendicular to \vec{c} , then $|\vec{b}|$ is equal to :

Options :

41652934938. 6

41652934939. 4

41652934940. $\sqrt{22}$

41652934941. $\sqrt{32}$

Question Number : 85 Question Id : 4165298870 Question Type : MCQ Option Shuffling : Yes Display Question Number : Yes
Single Line Question Option : No Option Orientation : Vertical

Correct Marks : 4 Wrong Marks : 1

माना $\vec{a} = \hat{i} + \hat{j} + \sqrt{2}\hat{k}$, $\vec{b} = b_1\hat{i} + b_2\hat{j} + \sqrt{2}\hat{k}$

तथा $\vec{c} = 5\hat{i} + \hat{j} + \sqrt{2}\hat{k}$ तीन ऐसे सदिश हैं कि

\vec{b} का \vec{a} पर प्रक्षेप सदिश, \vec{a} है। यदि $\vec{a} + \vec{b}$,

सदिश \vec{c} के लंबवत है, तो $|\vec{b}|$ बराबर है :

Options :

41652934938. 6

41652934939. 4

41652934940. $\sqrt{22}$

41652934941. $\sqrt{32}$

Question Number : 86 Question Id : 4165298871 Question Type : MCQ Option Shuffling : Yes Display Question Number : Yes
Single Line Question Option : No Option Orientation : Vertical

Correct Marks : 4 Wrong Marks : 1

A data consists of n observations :

x_1, x_2, \dots, x_n . If $\sum_{i=1}^n (x_i + 1)^2 = 9n$ and

$\sum_{i=1}^n (x_i - 1)^2 = 5n$, then the standard

deviation of this data is :

Options :

41652934942. $\sqrt{7}$

41652934943. $\sqrt{5}$

41652934944. 5

41652934945. 2

Question Number : 86 Question Id : 4165298871 Question Type : MCQ Option Shuffling : Yes Display Question Number : Yes
Single Line Question Option : No Option Orientation : Vertical

Correct Marks : 4 Wrong Marks : 1

आँकड़ों के एक समूह में n प्रेक्षण x_1, x_2, \dots, x_n हैं।

$$\text{यदि } \sum_{i=1}^n (x_i + 1)^2 = 9n \text{ तथा } \sum_{i=1}^n (x_i - 1)^2 = 5n$$

है, तो इन आँकड़ों का मानक विचलन है :

Options :

41652934942. $\sqrt{7}$

41652934943. $\sqrt{5}$

41652934944. 5

41652934945. 2

Question Number : 87 Question Id : 4165298872 Question Type : MCQ Option Shuffling : Yes Display Question Number : Yes
Single Line Question Option : No Option Orientation : Vertical

Correct Marks : 4 Wrong Marks : 1

An urn contains 5 red and 2 green balls. A ball is drawn at random from the urn. If the drawn ball is green, then a red ball is added to the urn and if the drawn ball is red, then a green ball is added to the urn; the original ball is not returned to the urn. Now, a second ball is drawn at random from it. The probability that the second ball is red, is :

Options :

41652934946. $\frac{27}{49}$

41652934947. $\frac{21}{49}$

41652934948. $\frac{26}{49}$

41652934949. $\frac{32}{49}$

Question Number : 87 Question Id : 4165298872 Question Type : MCQ Option Shuffling : Yes Display Question Number : Yes
Single Line Question Option : No Option Orientation : Vertical

Correct Marks : 4 Wrong Marks : 1

एक कलश में 5 लाल तथा 2 हरी गेंदें हैं। इस कलश में से यादृच्छया एक गेंद निकाली गई। यदि निकाली गई गेंद हरी है, तो कलश में एक लाल गेंद डाली जाती है तथा यदि निकाली गई गेंद लाल है, तो कलश में एक हरी गेंद डाली जाती है, जबकि निकाली गई गेंद वापिस नहीं डाली जाती। अब इसमें से यादृच्छया एक दूसरी गेंद निकाली गई, तो इस दूसरी गेंद के लाल होने की प्रायिकता है :

Options :

41652934946. $\frac{27}{49}$

41652934947. $\frac{21}{49}$

41652934948. $\frac{26}{49}$

41652934949. $\frac{32}{49}$

Question Number : 88 Question Id : 4165298873 Question Type : MCQ Option Shuffling : Yes Display Question Number : Yes Single Line Question Option : No Option Orientation : Vertical

Correct Marks : 4 Wrong Marks : 1

If $0 \leq x < \frac{\pi}{2}$, then the number of values of x for which $\sin x - \sin 2x + \sin 3x = 0$, is :

Options :

41652934950. 3

41652934951. 4

41652934952. 2

41652934953. 1

Question Number : 88 Question Id : 4165298873 Question Type : MCQ Option Shuffling : Yes Display Question Number : Yes Single Line Question Option : No Option Orientation : Vertical

Correct Marks : 4 Wrong Marks : 1

यदि $0 \leq x < \frac{\pi}{2}$ है, तो x के उन मानों की संख्या जिनके लिए $\sin x - \sin 2x + \sin 3x = 0$ है, है :

Options :

41652934950. 3

41652934951. 4

41652934952. 2

41652934953. 1

Question Number : 89 Question Id : 4165298874 Question Type : MCQ Option Shuffling : Yes Display Question Number : Yes
Single Line Question Option : No Option Orientation : Vertical

Correct Marks : 4 Wrong Marks : 1

If $x = \sin^{-1}(\sin 10)$ and $y = \cos^{-1}(\cos 10)$,
then $y - x$ is equal to :

Options :

41652934954. 0

41652934955. π

41652934956. 10

41652934957. 7π

Question Number : 89 Question Id : 4165298874 Question Type : MCQ Option Shuffling : Yes Display Question Number : Yes
Single Line Question Option : No Option Orientation : Vertical

Correct Marks : 4 Wrong Marks : 1

यदि $x = \sin^{-1}(\sin 10)$ तथा $y = \cos^{-1}(\cos 10)$ है,
तो $y - x$ बराबर है :

Options :

41652934954. 0

41652934955. π

41652934956. 10

41652934957. 7π

Question Number : 90 Question Id : 4165298875 Question Type : MCQ Option Shuffling : Yes Display Question Number : Yes
Single Line Question Option : No Option Orientation : Vertical

Correct Marks : 4 Wrong Marks : 1

The logical statement

$[\sim(\sim p \vee q) \vee (p \wedge r)] \wedge (\sim q \wedge r)$
is equivalent to :

Options :

41652934958. $\sim p \vee r$

41652934959. $(p \wedge r) \wedge \sim q$

41652934960. $(p \wedge \sim q) \vee r$

41652934961. $(\sim p \wedge \sim q) \wedge r$

Question Number : 90 Question Id : 4165298875 Question Type : MCQ Option Shuffling : Yes Display Question Number : Yes
Single Line Question Option : No Option Orientation : Vertical

Correct Marks : 4 Wrong Marks : 1

तर्कसंगत कथन

$$[\sim(\sim p \vee q) \vee (p \wedge r)] \wedge (\sim q \wedge r)$$

निम्न में से किसके समतुल्य है?

Options :

41652934958. $\sim p \vee r$

41652934959. $(p \wedge r) \wedge \sim q$

41652934960. $(p \wedge \sim q) \vee r$

41652934961. $(\sim p \wedge \sim q) \wedge r$