

# National Testing Agency

Question Paper Name:	Paper I EH 12th April 2019 Shift 2
Subject Name:	Paper I EH
Creation Date:	2019-04-12 19:35:38
Duration:	180
Total Marks:	360
Display Marks:	Yes
Share Answer Key With Delivery Engine:	Yes
Actual Answer Key:	Yes

## Paper I

Group Number :	1
Group Id :	416529160
Group Maximum Duration :	0
Group Minimum Duration :	180
Revisit allowed for view? :	No
Revisit allowed for edit? :	No
Break time:	0
Group Marks:	360

## Physics

Section Id :	416529274
Section Number :	1
Section type :	Online
Mandatory or Optional:	Mandatory
Number of Questions:	30
Number of Questions to be attempted:	30
Section Marks:	120
Display Number Panel:	Yes
Group All Questions:	No

Sub-Section Number:	1
Sub-Section Id:	416529414
Question Shuffling Allowed :	Yes

Question Number : 1 Question Id : 41652913416 Question Type : MCQ Option Shuffling : Yes Display Question Number : Yes  
Single Line Question Option : No Option Orientation : Vertical  
Correct Marks : 4 Wrong Marks : 1

The number density of molecules of a gas depends on their distance  $r$  from the origin as,  $n(r) = n_0 e^{-ar^4}$ . Then the total number of molecules is proportional to :

Options :

41652952442.  $n_0\alpha^{-3}$

41652952443.  $\sqrt{n_0} \alpha^{1/2}$

41652952444.  $n_0\alpha^{-3/4}$

41652952445.  $n_0\alpha^{1/4}$

Question Number : 1 Question Id : 41652913416 Question Type : MCQ Option Shuffling : Yes Display Question Number : Yes  
Single Line Question Option : No Option Orientation : Vertical

Correct Marks : 4 Wrong Marks : 1

एक गैस के अणुओं का संख्या घनत्व मूल बिन्दु से दूरी  $r$  पर निम्न ढंग से निर्भर है,  $n(r) = n_0 e^{-\alpha r^4}$ । तो इस गैस के अणुओं की कुल संख्या किसके समानुपाती होगी ?

Options :

41652952442.  $n_0\alpha^{-3}$

41652952443.  $\sqrt{n_0} \alpha^{1/2}$

41652952444.  $n_0\alpha^{-3/4}$

41652952445.  $n_0\alpha^{1/4}$

Question Number : 2 Question Id : 41652913417 Question Type : MCQ Option Shuffling : Yes Display Question Number : Yes  
Single Line Question Option : No Option Orientation : Vertical

Correct Marks : 4 Wrong Marks : 1

A particle is moving with speed  $v = b\sqrt{x}$  along positive  $x$ -axis. Calculate the speed of the particle at time  $t = \tau$  (assume that the particle is at origin at  $t = 0$ ).

Options :

41652952446.  $\frac{b^2\tau}{4}$

41652952447.  $\frac{b^2\tau}{\sqrt{2}}$

41652952448.  $\frac{b^2 \tau}{2}$

41652952449.  $b^2 \tau$

Question Number : 2 Question Id : 41652913417 Question Type : MCQ Option Shuffling : Yes Display Question Number : Yes  
Single Line Question Option : No Option Orientation : Vertical

Correct Marks : 4 Wrong Marks : 1

एक कण चाल  $v = b \sqrt{x}$  से धनात्मक  $x$ -अक्ष की दिशा में चल रहा है। समय  $t = \tau$  पर कण की चाल होगी :  
(माना कि  $t = 0$  पर कण मूल बिन्दु पर है।)

Options :

41652952446.  $\frac{b^2 \tau}{4}$

41652952447.  $\frac{b^2 \tau}{\sqrt{2}}$

41652952448.  $\frac{b^2 \tau}{2}$

41652952449.  $b^2 \tau$

Question Number : 3 Question Id : 41652913418 Question Type : MCQ Option Shuffling : Yes Display Question Number : Yes  
Single Line Question Option : No Option Orientation : Vertical

Correct Marks : 4 Wrong Marks : 1

Two particles are projected from the same point with the same speed  $u$  such that they have the same range  $R$ , but different maximum heights,  $h_1$  and  $h_2$ . Which of the following is correct ?

Options :

41652952450.  $R^2 = 16 h_1 h_2$

41652952451.  $R^2 = 4 h_1 h_2$

41652952452.  $R^2 = 2 h_1 h_2$

41652952453.  $R^2 = h_1 h_2$

Question Number : 3 Question Id : 41652913418 Question Type : MCQ Option Shuffling : Yes Display Question Number : Yes  
Single Line Question Option : No Option Orientation : Vertical

Correct Marks : 4 Wrong Marks : 1

दो कणों को एक ही बिन्दु से एक ही चाल  $u$  से प्रक्षेपित किया जाता है जिससे उनकी परास  $R$  बराबर हैं किन्तु अधिकतम ऊँचाइयाँ  $h_1$  तथा  $h_2$  भिन्न हैं। निम्न में सत्य कथन चुनिये।

Options :

41652952450.  $R^2 = 16 h_1 h_2$

41652952451.  $R^2 = 4 h_1 h_2$

41652952452.  $R^2 = 2 h_1 h_2$

41652952453.  $R^2 = h_1 h_2$

Question Number : 4 Question Id : 41652913419 Question Type : MCQ Option Shuffling : Yes Display Question Number : Yes  
Single Line Question Option : No Option Orientation : Vertical

Correct Marks : 4 Wrong Marks : 1

A block of mass 5 kg is (i) pushed in case (A) and (ii) pulled in case (B), by a force  $F = 20$  N, making an angle of  $30^\circ$  with the horizontal, as shown in the figures. The coefficient of friction between the block and floor is  $\mu = 0.2$ . The difference between the accelerations of the block, in case (B) and case (A) will be : ( $g = 10 \text{ ms}^{-2}$ )

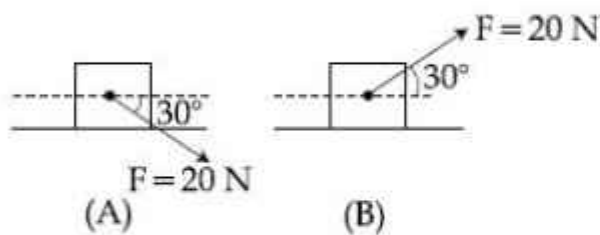

Options :

41652952454.  $0 \text{ ms}^{-2}$

41652952455.  $3.2 \text{ ms}^{-2}$

41652952456.  $0.4 \text{ ms}^{-2}$

41652952457.  $0.8 \text{ ms}^{-2}$

Question Number : 4 Question Id : 41652913419 Question Type : MCQ Option Shuffling : Yes Display Question Number : Yes  
Single Line Question Option : No Option Orientation : Vertical

Correct Marks : 4 Wrong Marks : 1

5 kg के एक गुटके को क्षैतिज से  $30^\circ$  कोण पर बल  $F = 20 \text{ N}$  से चित्रानुसार (i) दशा (A) में धकेलते हैं तथा (ii) दशा (B) में खींचते हैं। गुटके तथा समतल के बीच घर्षण गुणांक  $\mu = 0.2$  है। इन दो दशाओं (A) तथा (B), में गुटके के त्वरणों के अन्तर का मान होगा : ( $g = 10 \text{ ms}^{-2}$ )

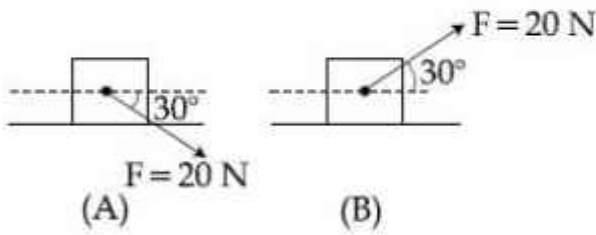

Options :

41652952454.  $0 \text{ ms}^{-2}$

41652952455.  $3.2 \text{ ms}^{-2}$

41652952456.  $0.4 \text{ ms}^{-2}$

41652952457.  $0.8 \text{ ms}^{-2}$

Question Number : 5 Question Id : 41652913420 Question Type : MCQ Option Shuffling : Yes Display Question Number : Yes  
Single Line Question Option : No Option Orientation : Vertical

Correct Marks : 4 Wrong Marks : 1

A spring whose unstretched length is  $l$  has a force constant  $k$ . The spring is cut into two pieces of unstretched lengths  $l_1$  and  $l_2$  where,  $l_1 = nl_2$  and  $n$  is an integer. The ratio  $k_1/k_2$  of the corresponding force constants,  $k_1$  and  $k_2$  will be :

Options :

41652952458.  $n$

41652952459.  $\frac{1}{n}$

41652952460.  $n^2$

41652952461.  $\frac{1}{n^2}$

Question Number : 5 Question Id : 41652913420 Question Type : MCQ Option Shuffling : Yes Display Question Number : Yes  
Single Line Question Option : No Option Orientation : Vertical

Correct Marks : 4 Wrong Marks : 1

एक स्प्रिंग की स्वतंत्र लम्बाई  $l$  तथा बल नियतांक  $k$  है। इसे काटकर  $l_1$  तथा  $l_2$  स्वतंत्र लम्बाई की दो स्प्रिंगों में बाँटते हैं।  $l_1 = nl_2$  है, जहाँ  $n$  एक पूर्णांक है। इनसे सम्बद्ध बल नियतांकों  $k_1$  तथा  $k_2$  का अनुपात,  $k_1/k_2$  होगा :

Options :

41652952458.  $n$

41652952459.  $\frac{1}{n}$

41652952460.  $n^2$

41652952461.  $\frac{1}{n^2}$

Question Number : 6 Question Id : 41652913421 Question Type : MCQ Option Shuffling : Yes Display Question Number : Yes  
Single Line Question Option : No Option Orientation : Vertical

Correct Marks : 4 Wrong Marks : 1

A smooth wire of length  $2\pi r$  is bent into a circle and kept in a vertical plane. A bead can slide smoothly on the wire. When the circle is rotating with angular speed  $\omega$  about the vertical diameter AB, as shown in figure, the bead is at rest with respect to the circular ring at position P as shown. Then the value of  $\omega^2$  is equal to :

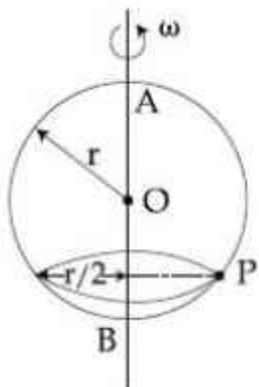

Options :

41652952462.  $2g/r$

41652952463.  $\frac{\sqrt{3}g}{2r}$

41652952464.  $(g\sqrt{3})/r$

41652952465.  $2g/(r\sqrt{3})$

Question Number : 6 Question Id : 41652913421 Question Type : MCQ Option Shuffling : Yes Display Question Number : Yes  
Single Line Question Option : No Option Orientation : Vertical

Correct Marks : 4 Wrong Marks : 1

$2\pi r$  लम्बाई के एक घर्षण रहित तार को वृत्त बनाकर ऊर्ध्वाधर समतल में रखा है। एक मणिका (bead) इस तार पर फिसलती है। वृत्त को एक ऊर्ध्वाधर अक्ष AB के परितः चित्रानुसार कोणीय वेग  $\omega$  से घुमाया जाता है तो वृत्त के सापेक्ष मणिका चित्रानुसार बिन्दु P पर स्थिर पायी जाती है।  $\omega^2$  का मान होगा :

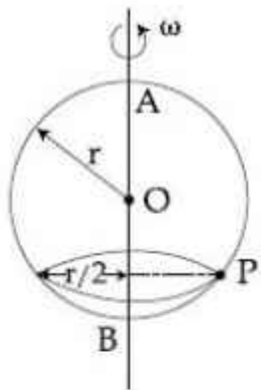

Options :

41652952462.  $2g/r$

41652952463.  $\frac{\sqrt{3}g}{2r}$

41652952464.  $(g\sqrt{3})/r$

41652952465.  $2g/(r\sqrt{3})$

Question Number : 7 Question Id : 41652913422 Question Type : MCQ Option Shuffling : Yes Display Question Number : Yes  
Single Line Question Option : No Option Orientation : Vertical

Correct Marks : 4 Wrong Marks : 1

Three particles of masses 50 g, 100 g and 150 g are placed at the vertices of an equilateral triangle of side 1 m (as shown in the figure). The  $(x, y)$  coordinates of the centre of mass will be :

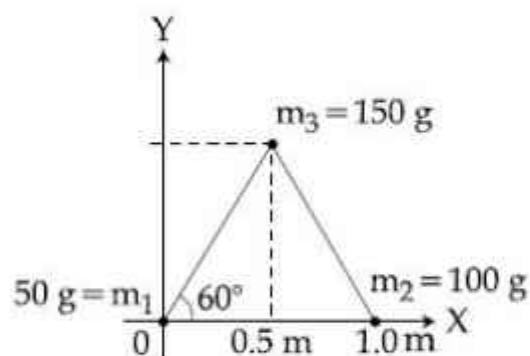

Options :

41652952466.  $\left( \frac{7}{12} \text{ m}, \frac{\sqrt{3}}{8} \text{ m} \right)$

41652952467.  $\left( \frac{7}{12} \text{ m}, \frac{\sqrt{3}}{4} \text{ m} \right)$

41652952468.  $\left( \frac{\sqrt{3}}{4} \text{ m}, \frac{5}{12} \text{ m} \right)$

41652952469.  $\left( \frac{\sqrt{3}}{8} \text{ m}, \frac{7}{12} \text{ m} \right)$

Question Number : 7 Question Id : 41652913422 Question Type : MCQ Option Shuffling : Yes Display Question Number : Yes Single Line Question Option : No Option Orientation : Vertical

Correct Marks : 4 Wrong Marks : 1



50 g, 100 g तथा 150 g के तीन कणों को चित्रानुसार 1 m भुजा वाले एक समबाहु त्रिभुज के कोनों पर रखा है। इस निकाय के द्रव्यमान केन्द्र (x तथा y) के निर्देशांक होंगे :

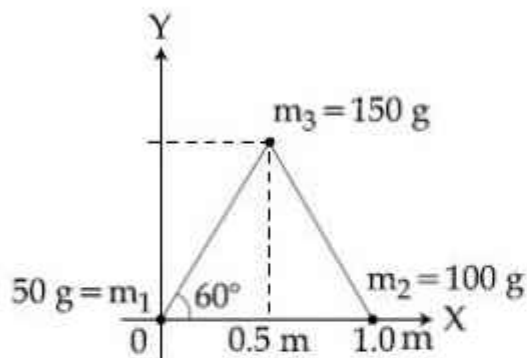

Options :

41652952466.  $\left(\frac{7}{12} \text{ m}, \frac{\sqrt{3}}{8} \text{ m}\right)$

41652952467.  $\left(\frac{7}{12} \text{ m}, \frac{\sqrt{3}}{4} \text{ m}\right)$

41652952468.  $\left(\frac{\sqrt{3}}{4} \text{ m}, \frac{5}{12} \text{ m}\right)$

41652952469.  $\left(\frac{\sqrt{3}}{8} \text{ m}, \frac{7}{12} \text{ m}\right)$

Question Number : 8 Question Id : 41652913423 Question Type : MCQ Option Shuffling : Yes Display Question Number : Yes  
Single Line Question Option : No Option Orientation : Vertical  
Correct Marks : 4 Wrong Marks : 1

The ratio of the weights of a body on the Earth's surface to that on the surface of a planet is 9 : 4. The mass of the planet is  $\frac{1}{9}$ th of that of the Earth. If 'R' is the radius of the Earth, what is the radius of the planet ? (Take the planets to have the same mass density)

Options :

41652952470.  $\frac{R}{2}$

41652952471.  $\frac{R}{3}$

41652952472.  $\frac{R}{9}$

41652952473.  $\frac{R}{4}$

Question Number : 8 Question Id : 41652913423 Question Type : MCQ Option Shuffling : Yes Display Question Number : Yes  
Single Line Question Option : No Option Orientation : Vertical

Correct Marks : 4 Wrong Marks : 1

एक पिण्ड के पृथ्वी तथा एक दूसरे ग्रह की सतह पर भारों का अनुपात 9 : 4 हैं। दूसरे ग्रह का द्रव्यमान पृथ्वी के द्रव्यमान का  $\frac{1}{9}$  है। यदि पृथ्वी की त्रिज्या 'R' है तो ग्रह की त्रिज्या क्या होगी? (माना कि दोनों ग्रहों का द्रव्यमान घनत्व समान है।)

Options :

41652952470.  $\frac{R}{2}$

41652952471.  $\frac{R}{3}$

41652952472.  $\frac{R}{9}$

41652952473.  $\frac{R}{4}$

Question Number : 9 Question Id : 41652913424 Question Type : MCQ Option Shuffling : Yes Display Question Number : Yes  
Single Line Question Option : No Option Orientation : Vertical

Correct Marks : 4 Wrong Marks : 1

A uniform cylindrical rod of length  $L$  and radius  $r$ , is made from a material whose Young's modulus of Elasticity equals  $Y$ . When this rod is heated by temperature  $T$  and simultaneously subjected to a net longitudinal compressional force  $F$ , its length remains unchanged. The coefficient of volume expansion, of the material of the rod, is (nearly) equal to :

Options :

41652952474.  $6F/(\pi r^2 Y T)$

41652952475.  $9F/(\pi r^2 Y T)$

41652952476.  $3F/(\pi r^2 Y T)$

41652952477.  $F/(3\pi r^2 Y T)$

Question Number : 9 Question Id : 41652913424 Question Type : MCQ Option Shuffling : Yes Display Question Number : Yes  
Single Line Question Option : No Option Orientation : Vertical

Correct Marks : 4 Wrong Marks : 1

लम्बाई  $L$  तथा त्रिज्या  $r$  की एक एकसमान बेलनाकार छड़ का यंग प्रत्यास्थता गुणांक  $Y$  है। जब इस छड़ का तापमान  $T$  से बढ़ाते हैं तथा उस पर कुल अनुदैर्घ्य संपीडन बल  $F$  लगाते हैं, तो उसकी लम्बाई अपरिवर्तित रहती है। छड़ के पदार्थ के आयतन प्रसार गुणांक का लगभग मान होगा :

Options :

41652952474.  $6F/(\pi r^2 Y T)$

41652952475.  $9F/(\pi r^2 Y T)$

41652952476.  $3F/(\pi r^2 Y T)$

41652952477.  $F/(3\pi r^2 Y T)$

Question Number : 10 Question Id : 41652913425 Question Type : MCQ Option Shuffling : Yes Display Question Number : Yes  
Single Line Question Option : No Option Orientation : Vertical

Correct Marks : 4 Wrong Marks : 1

A solid sphere, of radius  $R$  acquires a terminal velocity  $v_1$  when falling (due to gravity) through a viscous fluid having a coefficient of viscosity  $\eta$ . The sphere is broken into 27 identical solid spheres. If each of these spheres acquires a terminal velocity,  $v_2$ , when falling through the same fluid, the ratio  $(v_1/v_2)$  equals :

Options :

41652952478. 9

41652952479.  $1/9$

41652952480. 27

41652952481.  $1/27$

Question Number : 10 Question Id : 41652913425 Question Type : MCQ Option Shuffling : Yes Display Question Number : Yes  
Single Line Question Option : No Option Orientation : Vertical

Correct Marks : 4 Wrong Marks : 1

त्रिज्या  $R$  के एक ठोस गोले का, श्यानता गुणांक  $\eta$  के एक द्रव में (गुरुत्वीय बल के कारण) सीमान्त वेग  $v_1$  है। यदि इस ठोस गोले को बराबर त्रिज्या के 27 गोलों में बाँटा जाये तो प्रत्येक गोले का सीमान्त वेग इसी द्रव में  $v_2$  पाया जाता है, तो  $v_1/v_2$  का मान होगा :

Options :

41652952478. 9

41652952479.  $1/9$

41652952480. 27

41652952481.  $1/27$

Question Number : 11 Question Id : 41652913426 Question Type : MCQ Option Shuffling : Yes Display Question Number : Yes  
Single Line Question Option : No Option Orientation : Vertical

Correct Marks : 4 Wrong Marks : 1

A Carnot engine has an efficiency of  $1/6$ . When the temperature of the sink is reduced by  $62^\circ\text{C}$ , its efficiency is doubled. The temperatures of the source and the sink are, respectively,

Options :

41652952482.  $99^\circ\text{C}, 37^\circ\text{C}$

41652952483.  $124^\circ\text{C}, 62^\circ\text{C}$

41652952484.  $37^\circ\text{C}, 99^\circ\text{C}$

41652952485.  $62^\circ\text{C}, 124^\circ\text{C}$

Question Number : 11 Question Id : 41652913426 Question Type : MCQ Option Shuffling : Yes Display Question Number : Yes Single Line Question Option : No Option Orientation : Vertical

Correct Marks : 4 Wrong Marks : 1

एक कार्नो इंजन की क्षमता  $1/6$  है। जब ऊष्मा कुण्ड (sink) का तापमान  $62^\circ\text{C}$  कम किया जाता है तो क्षमता दोगुनी हो जाती है। ऊष्मा स्रोत तथा कुण्ड के, क्रमशः, तापमान होंगे :

Options :

41652952482.  $99^\circ\text{C}, 37^\circ\text{C}$

41652952483.  $124^\circ\text{C}, 62^\circ\text{C}$

41652952484.  $37^\circ\text{C}, 99^\circ\text{C}$

41652952485.  $62^\circ\text{C}, 124^\circ\text{C}$

Question Number : 12 Question Id : 41652913427 Question Type : MCQ Option Shuffling : Yes Display Question Number : Yes Single Line Question Option : No Option Orientation : Vertical

Correct Marks : 4 Wrong Marks : 1

A diatomic gas with rigid molecules does 10 J of work when expanded at constant pressure. What would be the heat energy absorbed by the gas, in this process ?

Options :

41652952486. 25 J

41652952487. 30 J

41652952488. 35 J

41652952489. 40 J

Question Number : 12 Question Id : 41652913427 Question Type : MCQ Option Shuffling : Yes Display Question Number : Yes  
Single Line Question Option : No Option Orientation : Vertical

Correct Marks : 4 Wrong Marks : 1

एक दृढ़ अणुओं वाली द्विपरमाणुक गैस का जब नियत दाब पर प्रसार होता है तो वह 10 J कार्य करती है। इस प्रक्रम में गैस द्वारा अवशोषित ऊष्मा का मान होगा :

Options :

41652952486. 25 J

41652952487. 30 J

41652952488. 35 J

41652952489. 40 J

Question Number : 13 Question Id : 41652913428 Question Type : MCQ Option Shuffling : Yes Display Question Number : Yes  
Single Line Question Option : No Option Orientation : Vertical

Correct Marks : 4 Wrong Marks : 1

A small speaker delivers 2 W of audio output. At what distance from the speaker will one detect 120 dB intensity sound ?  
[Given reference intensity of sound as  $10^{-12} \text{ W/m}^2$ ]

Options :

41652952490. 10 cm

41652952491. 20 cm

41652952492. 30 cm

41652952493. 40 cm

Question Number : 13 Question Id : 41652913428 Question Type : MCQ Option Shuffling : Yes Display Question Number : Yes  
Single Line Question Option : No Option Orientation : Vertical

Correct Marks : 4 Wrong Marks : 1

एक छोटे स्पीकर से 2 W शक्ति की ध्वनि निकलती है। इस स्पीकर से कितनी दूरी पर ध्वनि तीव्रता 120 dB होगी? [दिया है : ध्वनि की निर्देश (reference) तीव्रता =  $10^{-12} \text{ W/m}^2$ ]

Options :

41652952490. 10 cm

41652952491. 20 cm

41652952492. 30 cm

41652952493. 40 cm

Question Number : 14 Question Id : 41652913429 Question Type : MCQ Option Shuffling : Yes Display Question Number : Yes Single Line Question Option : No Option Orientation : Vertical

Correct Marks : 4 Wrong Marks : 1

Two sources of sound  $S_1$  and  $S_2$  produce sound waves of same frequency 660 Hz. A listener is moving from source  $S_1$  towards  $S_2$  with a constant speed  $u$  m/s and he hears 10 beats/s. The velocity of sound is 330 m/s. Then,  $u$  equals :

Options :

41652952494. 2.5 m/s

41652952495. 5.5 m/s

41652952496. 10.0 m/s

41652952497. 15.0 m/s

Question Number : 14 Question Id : 41652913429 Question Type : MCQ Option Shuffling : Yes Display Question Number : Yes Single Line Question Option : No Option Orientation : Vertical

Correct Marks : 4 Wrong Marks : 1

दो ध्वनि स्रोत,  $S_1$  तथा  $S_2$ , एक ही आवृत्ति 660 Hz की ध्वनि उत्पन्न करते हैं। एक श्रोता  $S_1$  से  $S_2$  की तरफ स्थिर गति  $u$  से जाते हुये प्रति सेकण्ड 10 विस्पंद सुनता है। यदि ध्वनि की गति 330 m/s है, तो  $u$  का मान होगा :

Options :

41652952494. 2.5 m/s

41652952495. 5.5 m/s

41652952496. 10.0 m/s

41652952497. 15.0 m/s

Question Number : 15 Question Id : 41652913430 Question Type : MCQ Option Shuffling : Yes Display Question Number : Yes  
Single Line Question Option : No Option Orientation : Vertical

Correct Marks : 4 Wrong Marks : 1

Let a total charge  $2Q$  be distributed in a sphere of radius  $R$ , with the charge density given by  $\rho(r) = kr$ , where  $r$  is the distance from the centre. Two charges  $A$  and  $B$ , of  $-Q$  each, are placed on diametrically opposite points, at equal distance,  $a$ , from the centre. If  $A$  and  $B$  do not experience any force, then :

Options :

41652952498.  $a = 8^{-1/4} R$

41652952499.  $a = 2^{-1/4} R$

41652952500.  $a = R/\sqrt{3}$

41652952501.  $a = \frac{3R}{2^{1/4}}$

Question Number : 15 Question Id : 41652913430 Question Type : MCQ Option Shuffling : Yes Display Question Number : Yes  
Single Line Question Option : No Option Orientation : Vertical

Correct Marks : 4 Wrong Marks : 1

कुल आवेश  $2Q$  को त्रिज्या  $R$  के गोले में इस प्रकार वितरित करते हैं कि आवेश घनत्व सम्बन्ध  $\rho(r) = kr$  से दिया जाता है जहाँ  $r$ , केन्द्र से दूरी है। दो बराबर  $-Q$  आवेशों  $A$  तथा  $B$  को केन्द्र से  $a$  दूरी पर व्यासीय विपरीत बिन्दुओं पर रखा गया है। यदि  $A$  और  $B$  कोई बल अनुभव नहीं करते हैं, तो :

Options :

41652952498.  $a = 8^{-1/4} R$



41652952499.  $a = 2^{-1/4} R$

41652952500.  $a = R/\sqrt{3}$

41652952501.  $a = \frac{3R}{2^{1/4}}$

Question Number : 16 Question Id : 41652913431 Question Type : MCQ Option Shuffling : Yes Display Question Number : Yes  
 Single Line Question Option : No Option Orientation : Vertical  
 Correct Marks : 4 Wrong Marks : 1

In the given circuit, the charge on  $4 \mu\text{F}$  capacitor will be :

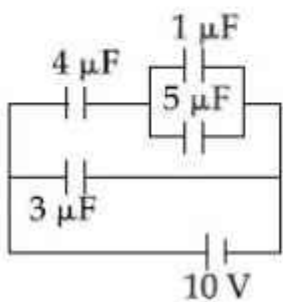

Options :

41652952502.  $9.6 \mu\text{C}$

41652952503.  $24 \mu\text{C}$

41652952504.  $5.4 \mu\text{C}$

41652952505.  $13.4 \mu\text{C}$

Question Number : 16 Question Id : 41652913431 Question Type : MCQ Option Shuffling : Yes Display Question Number : Yes  
 Single Line Question Option : No Option Orientation : Vertical  
 Correct Marks : 4 Wrong Marks : 1

दिये गये परिपथ में  $4 \mu\text{F}$  धारिता के संधारित्र पर आवेश का मान होगा :

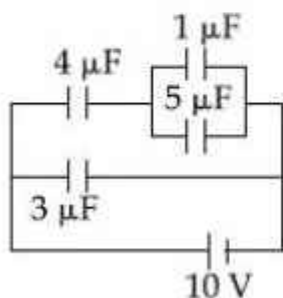

Options :

41652952502. 9.6  $\mu\text{C}$

41652952503. 24  $\mu\text{C}$

41652952504. 5.4  $\mu\text{C}$

41652952505. 13.4  $\mu\text{C}$

Question Number : 17 Question Id : 41652913432 Question Type : MCQ Option Shuffling : Yes Display Question Number : Yes  
Single Line Question Option : No Option Orientation : Vertical

Correct Marks : 4 Wrong Marks : 1

One kg of water, at  $20^\circ\text{C}$ , is heated in an electric kettle whose heating element has a mean (temperature averaged) resistance of  $20 \Omega$ . The rms voltage in the mains is 200 V. Ignoring heat loss from the kettle, time taken for water to evaporate fully, is close to :

[Specific heat of water =  $4200 \text{ J}/(\text{kg } ^\circ\text{C})$ ,  
Latent heat of water =  $2260 \text{ kJ}/\text{kg}$ ]

Options :

41652952506. 3 minutes

41652952507. 10 minutes

41652952508. 22 minutes

41652952509. 16 minutes

Question Number : 17 Question Id : 41652913432 Question Type : MCQ Option Shuffling : Yes Display Question Number : Yes  
Single Line Question Option : No Option Orientation : Vertical

Correct Marks : 4 Wrong Marks : 1

माध्य प्रतिरोध ( तापमान औसत)  $20 \Omega$  की एक विद्युत केतली में  $20^\circ\text{C}$  के 1 kg पानी को उबालते हैं। विद्युत आपूर्ति की rms वोल्टता 200 V है। केतली से ऊष्मा हानि को नगण्य मानते हुए, पानी को पूर्णतया वाष्पित होने में लगभग समय लगेगा :

[पानी की विशिष्ट ऊष्मा =  $4200 \text{ J}/(\text{kg } ^\circ\text{C})$ ,  
पानी की गुप्त ऊष्मा =  $2260 \text{ kJ}/\text{kg}$ ]

Options :

41652952506. 3 मिनट

41652952507. 10 मिनट

41652952508. 22 मिनट

41652952509. 16 मिनट

Question Number : 18 Question Id : 41652913433 Question Type : MCQ Option Shuffling : Yes Display Question Number : Yes  
Single Line Question Option : No Option Orientation : Vertical

Correct Marks : 4 Wrong Marks : 1

An electron, moving along the  $x$ -axis with an initial energy of 100 eV, enters a region

of magnetic field  $\vec{B} = (1.5 \times 10^{-3} \text{T}) \hat{k}$  at S (See figure). The field extends between  $x = 0$  and  $x = 2$  cm. The electron is detected at the point Q on a screen placed 8 cm away from the point S. The distance  $d$  between P and Q (on the screen) is :

(electron's charge =  $1.6 \times 10^{-19} \text{C}$ , mass of electron =  $9.1 \times 10^{-31} \text{kg}$ )

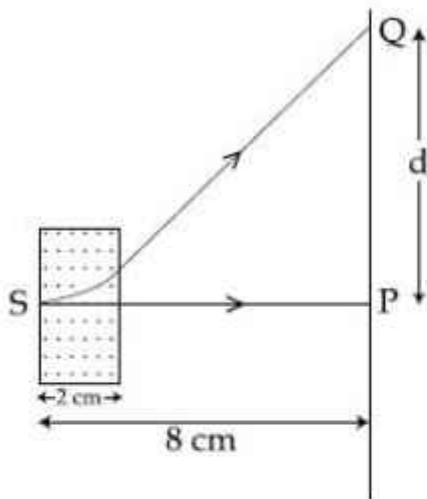

Options :

41652952510. 1.22 cm

41652952511. 12.87 cm

41652952512. 11.65 cm

41652952513. 2.25 cm

Question Number : 18 Question Id : 41652913433 Question Type : MCQ Option Shuffling : Yes Display Question Number : Yes  
Single Line Question Option : No Option Orientation : Vertical

Correct Marks : 4 Wrong Marks : 1

100 eV ऊर्जा का एक इलेक्ट्रॉन जो  $x$ -अक्ष के अनुदिश

गतिमान है,  $\vec{B} = (1.5 \times 10^{-3} \text{T}) \hat{k}$  के चुम्बकीय क्षेत्र में बिन्दु S पर प्रवेश करता है (चित्र देखिये)। चुम्बकीय क्षेत्र  $x=0$  से  $x=2 \text{ cm}$  तक विस्तृत है। बिन्दु S से 8 cm दूरी पर स्थित पर्दे पर इलेक्ट्रॉन का संसूचन बिन्दु Q पर होता है। बिन्दु P तथा Q के बीच की दूरी  $d$  (पर्दे पर) का मान होगा :

(इलेक्ट्रॉन का आवेश  $= 1.6 \times 10^{-19} \text{C}$ , इलेक्ट्रॉन का द्रव्यमान  $= 9.1 \times 10^{-31} \text{kg}$ )

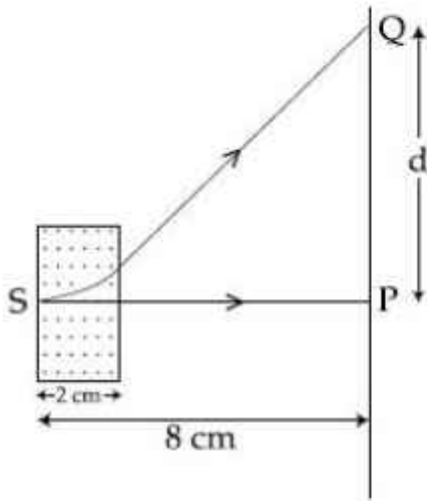

Options :

41652952510. 1.22 cm

41652952511. 12.87 cm

41652952512. 11.65 cm

41652952513. 2.25 cm

Question Number : 19 Question Id : 41652913434 Question Type : MCQ Option Shuffling : Yes Display Question Number : Yes  
Single Line Question Option : No Option Orientation : Vertical

Correct Marks : 4 Wrong Marks : 1

Find the magnetic field at point P due to a straight line segment AB of length 6 cm carrying a current of 5 A. (See figure)

$$(\mu_0 = 4\pi \times 10^{-7} \text{ N-A}^{-2})$$

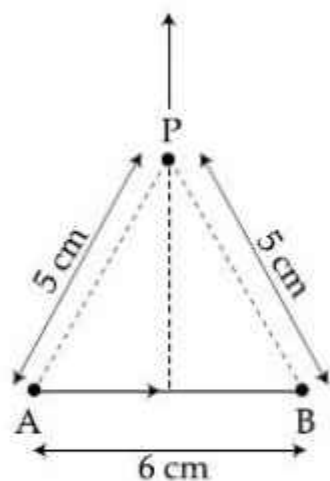

Options :

41652952514.  $1.5 \times 10^{-5} \text{ T}$

41652952515.  $2.0 \times 10^{-5} \text{ T}$

41652952516.  $2.5 \times 10^{-5} \text{ T}$

41652952517.  $3.0 \times 10^{-5} \text{ T}$

Question Number : 19 Question Id : 41652913434 Question Type : MCQ Option Shuffling : Yes Display Question Number : Yes  
Single Line Question Option : No Option Orientation : Vertical

Correct Marks : 4 Wrong Marks : 1

5 A धारा के एक सीधे तार के 6 cm लम्बे खण्ड AB के कारण, (चित्रानुसार), बिन्दु P पर चुम्बकीय क्षेत्र ज्ञात कीजिए।

$$(\mu_0 = 4\pi \times 10^{-7} \text{ N-A}^{-2})$$

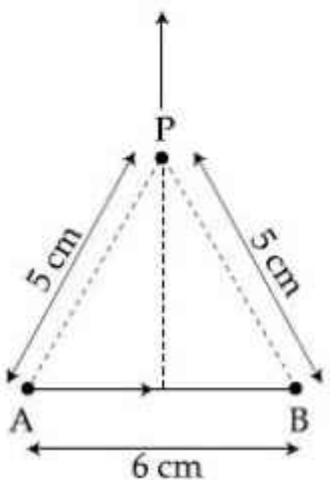

Options :

41652952514.  $1.5 \times 10^{-5} \text{ T}$

41652952515.  $2.0 \times 10^{-5} \text{ T}$

41652952516.  $2.5 \times 10^{-5} \text{ T}$

41652952517.  $3.0 \times 10^{-5} \text{ T}$

Question Number : 20 Question Id : 41652913435 Question Type : MCQ Option Shuffling : Yes Display Question Number : Yes  
Single Line Question Option : No Option Orientation : Vertical

Correct Marks : 4 Wrong Marks : 1

Consider the LR circuit shown in the figure.

If the switch S is closed at  $t=0$  then the amount of charge that passes through the

battery between  $t=0$  and  $t=\frac{L}{R}$  is :

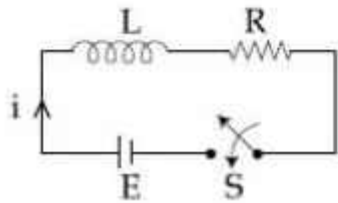

Options :

41652952518.  $\frac{7.3 EL}{R^2}$

41652952519.  $\frac{2.7 EL}{R^2}$

41652952520.  $\frac{EL}{2.7R^2}$

41652952521.  $\frac{EL}{7.3R^2}$

Question Number : 20 Question Id : 41652913435 Question Type : MCQ Option Shuffling : Yes Display Question Number : Yes  
Single Line Question Option : No Option Orientation : Vertical

Correct Marks : 4 Wrong Marks : 1

चित्र में एक LR परिपथ दर्शाया है। यदि  $t=0$  पर कुंजी S को बन्द करते हैं, तो सेल से निकलने वाले

आवेश का मान समयान्तराल  $t=0$  से  $t=\frac{L}{R}$  के बीच

होगा :

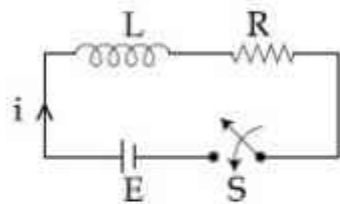

Options :

41652952518.  $\frac{7.3 EL}{R^2}$

41652952519.  $\frac{2.7 EL}{R^2}$

41652952520.  $\frac{EL}{2.7R^2}$

41652952521.  $\frac{EL}{7.3R^2}$

Question Number : 21 Question Id : 41652913436 Question Type : MCQ Option Shuffling : Yes Display Question Number : Yes Single Line Question Option : No Option Orientation : Vertical

Correct Marks : 4 Wrong Marks : 1

A plane electromagnetic wave having a frequency  $\nu = 23.9$  GHz propagates along the positive  $z$ -direction in free space. The peak value of the Electric Field is  $60$  V/m. Which among the following is the acceptable magnetic field component in the electromagnetic wave ?

Options :

41652952522.  $\vec{B} = 60 \sin(0.5 \times 10^3 x + 1.5 \times 10^{11} t) \hat{k}$

41652952523.  $\vec{B} = 2 \times 10^{-7} \sin(0.5 \times 10^3 z - 1.5 \times 10^{11} t) \hat{i}$

41652952524.  $\vec{B} = 2 \times 10^7 \sin(0.5 \times 10^3 z + 1.5 \times 10^{11} t) \hat{i}$

41652952525.  $\vec{B} = 2 \times 10^{-7} \sin(1.5 \times 10^2 x + 0.5 \times 10^{11} t) \hat{j}$

Question Number : 21 Question Id : 41652913436 Question Type : MCQ Option Shuffling : Yes Display Question Number : Yes  
Single Line Question Option : No Option Orientation : Vertical

Correct Marks : 4 Wrong Marks : 1

मुक्त आकाश में  $\nu = 23.9 \text{ GHz}$  की एक समतल विद्युत चुम्बकीय तरंग धनात्मक  $z$ -अक्ष की दिशा में संचरण कर रही है। इसमें विद्युत क्षेत्र का अधिकतम मान  $60 \text{ V/m}$  है। निम्न में से कौन सा विकल्प इस तरंग के चुम्बकीय क्षेत्र के लिये स्वीकार्य है ?

Options :

41652952522.  $\vec{B} = 60 \sin(0.5 \times 10^3 x + 1.5 \times 10^{11} t) \hat{k}$

41652952523.  $\vec{B} = 2 \times 10^{-7} \sin(0.5 \times 10^3 z - 1.5 \times 10^{11} t) \hat{i}$

41652952524.  $\vec{B} = 2 \times 10^7 \sin(0.5 \times 10^3 z + 1.5 \times 10^{11} t) \hat{i}$

41652952525.  $\vec{B} = 2 \times 10^{-7} \sin(1.5 \times 10^2 x + 0.5 \times 10^{11} t) \hat{j}$

Question Number : 22 Question Id : 41652913437 Question Type : MCQ Option Shuffling : Yes Display Question Number : Yes  
Single Line Question Option : No Option Orientation : Vertical

Correct Marks : 4 Wrong Marks : 1

A transparent cube of side  $d$ , made of a material of refractive index  $\mu_2$ , is immersed in a liquid of refractive index  $\mu_1$  ( $\mu_1 < \mu_2$ ). A ray is incident on the face AB at an angle  $\theta$  (shown in the figure). Total internal reflection takes place at point E on the face BC.

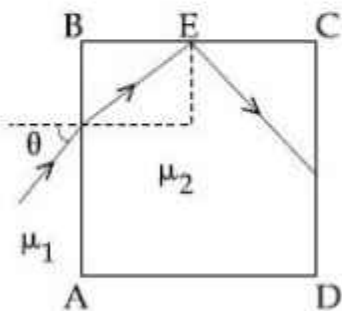

Then  $\theta$  must satisfy :

Options :



$$\theta < \sin^{-1} \sqrt{\frac{\mu_2^2}{\mu_1^2} - 1}$$

41652952526.

$$\theta > \sin^{-1} \sqrt{\frac{\mu_2^2}{\mu_1^2} - 1}$$

41652952527.

$$\theta > \sin^{-1} \frac{\mu_1}{\mu_2}$$

41652952528.

$$\theta < \sin^{-1} \frac{\mu_1}{\mu_2}$$

41652952529.

Question Number : 22 Question Id : 41652913437 Question Type : MCQ Option Shuffling : Yes Display Question Number : Yes Single Line Question Option : No Option Orientation : Vertical

Correct Marks : 4 Wrong Marks : 1

अपवर्तनांक  $\mu_1$  के एक द्रव में अपवर्तनांक  $\mu_2 (\mu_1 < \mu_2)$  के पारदर्शी गुटके को डुबाया जाता है। प्रकाश की एक किरण इस गुटके के पृष्ठ AB पर द्रव से, चित्रानुसार,  $\theta$  कोण पर आपतित होती है। पृष्ठ BC के बिन्दु E पर पूर्ण आन्तरिक परावर्तन होने के लिये,  $\theta$  का मान कौन सा सम्बन्ध संतुष्ट करेगा ?

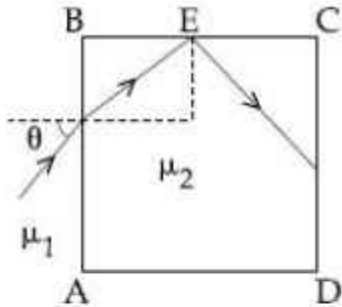

Options :

$$\theta < \sin^{-1} \sqrt{\frac{\mu_2^2}{\mu_1^2} - 1}$$

41652952526.

$$\theta > \sin^{-1} \sqrt{\frac{\mu_2^2}{\mu_1^2} - 1}$$

41652952527.

$$\theta > \sin^{-1} \frac{\mu_1}{\mu_2}$$

41652952528.

$$\theta < \sin^{-1} \frac{\mu_1}{\mu_2}$$

41652952529.

Question Number : 23 Question Id : 41652913438 Question Type : MCQ Option Shuffling : Yes Display Question Number : Yes  
Single Line Question Option : No Option Orientation : Vertical

Correct Marks : 4 Wrong Marks : 1

A system of three polarizers  $P_1, P_2, P_3$  is set up such that the pass axis of  $P_3$  is crossed with respect to that of  $P_1$ . The pass axis of  $P_2$  is inclined at  $60^\circ$  to the pass axis of  $P_3$ . When a beam of unpolarized light of intensity  $I_0$  is incident on  $P_1$ , the intensity of light transmitted by the three polarizers is  $I$ . The ratio  $(I_0/I)$  equals (nearly) :

Options :

41652952530. 1.80

41652952531. 5.33

41652952532. 10.67

41652952533. 16.00

Question Number : 23 Question Id : 41652913438 Question Type : MCQ Option Shuffling : Yes Display Question Number : Yes  
Single Line Question Option : No Option Orientation : Vertical

Correct Marks : 4 Wrong Marks : 1

तीन ध्रुवकों  $P_1, P_2$  तथा  $P_3$  को इस तरह रखते हैं कि  $P_3$  की पास-अक्ष  $P_1$  की पास-अक्ष से क्रॉसित है।  $P_2$  की पास-अक्ष  $P_3$  की पास-अक्ष से  $60^\circ$  कोण पर है। जब एक  $I_0$  तीव्रता का अध्रुवित प्रकाश किरण पुंज  $P_1$  पर आपतित होता है तो इस तीन ध्रुवकों के समायोजन से  $I$  तीव्रता का प्रकाश किरण पुंज निर्गत होता है। अनुपात  $(I_0/I)$  का निकटतम मान होगा :

Options :

41652952530. 1.80

41652952531. 5.33

41652952532. 10.67

41652952533. 16.00

Question Number : 24 Question Id : 41652913439 Question Type : MCQ Option Shuffling : Yes Display Question Number : Yes  
Single Line Question Option : No Option Orientation : Vertical

Correct Marks : 4 Wrong Marks : 1

Consider an electron in a hydrogen atom, revolving in its second excited state (having radius  $4.65 \text{ \AA}$ ). The de-Broglie wavelength of this electron is :

Options :

41652952534.  $3.5 \text{ \AA}$

41652952535.  $6.6 \text{ \AA}$

41652952536.  $9.7 \text{ \AA}$

41652952537.  $12.9 \text{ \AA}$

Question Number : 24 Question Id : 41652913439 Question Type : MCQ Option Shuffling : Yes Display Question Number : Yes  
Single Line Question Option : No Option Orientation : Vertical

Correct Marks : 4 Wrong Marks : 1

एक हाइड्रोजन परमाणु में इलेक्ट्रॉन दूसरी उत्तेजित कक्षा में घूम रहा है। (इस कक्षा की त्रिज्या  $4.65 \text{ \AA}$  है।) इस इलेक्ट्रॉन की डि-ब्रॉग्ली तरंगदैर्घ्य होगी :

Options :

41652952534.  $3.5 \text{ \AA}$

41652952535.  $6.6 \text{ \AA}$

41652952536.  $9.7 \text{ \AA}$

41652952537.  $12.9 \text{ \AA}$

Question Number : 25 Question Id : 41652913440 Question Type : MCQ Option Shuffling : Yes Display Question Number : Yes  
Single Line Question Option : No Option Orientation : Vertical

Correct Marks : 4 Wrong Marks : 1

The electron in a hydrogen atom first jumps from the third excited state to the second excited state and subsequently to the first excited state. The ratio of the respective wavelengths,  $\lambda_1/\lambda_2$ , of the photons emitted in this process is :

Options :

41652952538.  $27/5$

41652952539.  $7/5$

41652952540.  $9/7$

41652952541.  $20/7$

Question Number : 25 Question Id : 41652913440 Question Type : MCQ Option Shuffling : Yes Display Question Number : Yes  
Single Line Question Option : No Option Orientation : Vertical

Correct Marks : 4 Wrong Marks : 1

एक हाइड्रोजन परमाणु में इलेक्ट्रॉन पहले तीसरी उत्तेजित अवस्था से दूसरी उत्तेजित अवस्था में और तत्पश्चात् दूसरी से प्रथम उत्तेजित अवस्था में जाता है। इन दो संक्रमणों में उत्सर्जित फोटॉनों के संगत तरंगदैर्घ्यों का अनुपात  $\lambda_1/\lambda_2$  होगा :

Options :

41652952538.  $27/5$

41652952539.  $7/5$

41652952540.  $9/7$

41652952541.  $20/7$

Question Number : 26 Question Id : 41652913441 Question Type : MCQ Option Shuffling : Yes Display Question Number : Yes  
Single Line Question Option : No Option Orientation : Vertical

Correct Marks : 4 Wrong Marks : 1

Half lives of two radioactive nuclei A and B are 10 minutes and 20 minutes, respectively. If, initially a sample has equal number of nuclei, then after 60 minutes, the ratio of decayed numbers of nuclei A and B will be :

Options :

41652952542. 1 : 8

41652952543. 9 : 8

41652952544. 8 : 1

41652952545. 3 : 8

Question Number : 26 Question Id : 41652913441 Question Type : MCQ Option Shuffling : Yes Display Question Number : Yes  
Single Line Question Option : No Option Orientation : Vertical

Correct Marks : 4 Wrong Marks : 1

दो रेडियोधर्मी नाभिकों, A तथा B, की अर्धआयु क्रमशः, 10 minutes तथा 20 minutes है। यदि एक नमूने में आरम्भ में दोनों नाभिकों की संख्या बराबर है तो 60 minutes पश्चात् A तथा B के क्षयित नाभिकों की संख्या का अनुपात होगा :

Options :

41652952542. 1 : 8

41652952543. 9 : 8

41652952544. 8 : 1

41652952545. 3 : 8

Question Number : 27 Question Id : 41652913442 Question Type : MCQ Option Shuffling : Yes Display Question Number : Yes  
Single Line Question Option : No Option Orientation : Vertical

Correct Marks : 4 Wrong Marks : 1

Figure shows a DC voltage regulator circuit, with a Zener diode of breakdown voltage = 6V. If the unregulated input voltage varies between 10 V to 16 V, then what is the maximum Zener current ?

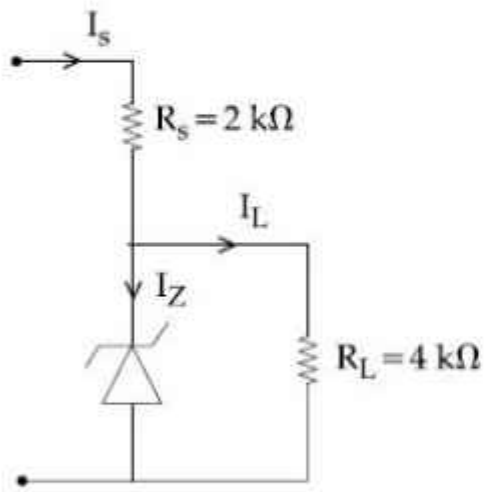

Options :

41652952546. 7.5 mA

41652952547. 1.5 mA

41652952548. 2.5 mA

41652952549. 3.5 mA

Question Number : 27 Question Id : 41652913442 Question Type : MCQ Option Shuffling : Yes Display Question Number : Yes  
Single Line Question Option : No Option Orientation : Vertical

Correct Marks : 4 Wrong Marks : 1

चित्र में भंजन वोल्टता = 6V के जेनर डायोड से बनाया विद्युत नियंत्रक परिपथ दिखाया है। यदि अनियंत्रित निवेशित विभव 10 V तथा 16 V के बीच बदलता है तो जेनर डायोड में अधिकतम धारा का मान होगा :

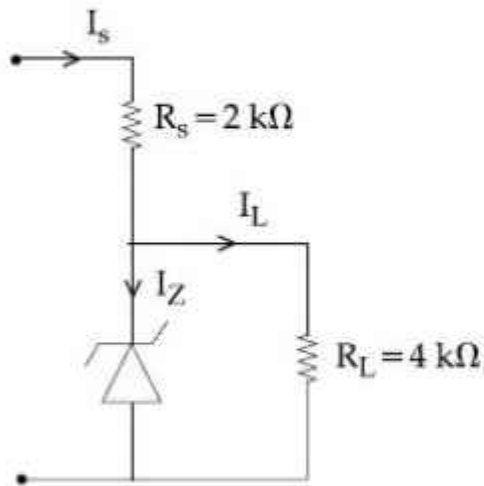

Options :

41652952546. 7.5 mA

41652952547. 1.5 mA

41652952548. 2.5 mA

41652952549. 3.5 mA

Question Number : 28 Question Id : 41652913443 Question Type : MCQ Option Shuffling : Yes Display Question Number : Yes Single Line Question Option : No Option Orientation : Vertical

Correct Marks : 4 Wrong Marks : 1

In an amplitude modulator circuit, the carrier wave is given by,

$C(t) = 4 \sin(20000 \pi t)$  while modulating signal is given by,  $m(t) = 2 \sin(2000 \pi t)$ . The values of modulation index and lower side band frequency are :

Options :

41652952550. 0.3 and 9 kHz

41652952551. 0.4 and 10 kHz

41652952552. 0.5 and 10 kHz

41652952553. 0.5 and 9 kHz

Question Number : 28 Question Id : 41652913443 Question Type : MCQ Option Shuffling : Yes Display Question Number : Yes  
Single Line Question Option : No Option Orientation : Vertical

Correct Marks : 4 Wrong Marks : 1

एक आयामी मॉड्युलन परिपथ में निवेशी वाहक तरंग  
 $C(t) = 4 \sin(20000 \pi t)$  है, जबकि मॉड्युलन सिग्नल  
 $m(t) = 2 \sin(2000 \pi t)$  है। मॉड्युलन सूचकांक तथा  
निचली पार्श्व बैंड आवृत्ति के मान होंगे :

Options :

41652952550. 0.3 तथा 9 kHz

41652952551. 0.4 तथा 10 kHz

41652952552. 0.5 तथा 10 kHz

41652952553. 0.5 तथा 9 kHz

Question Number : 29 Question Id : 41652913444 Question Type : MCQ Option Shuffling : Yes Display Question Number : Yes  
Single Line Question Option : No Option Orientation : Vertical

Correct Marks : 4 Wrong Marks : 1

A tuning fork of frequency 480 Hz is used  
in an experiment for measuring speed of  
sound ( $v$ ) in air by resonance tube method.  
Resonance is observed to occur at two  
successive lengths of the air column,  
 $l_1 = 30$  cm and  $l_2 = 70$  cm. Then,  $v$  is equal  
to :

Options :

41652952554.  $338 \text{ ms}^{-1}$

41652952555.  $379 \text{ ms}^{-1}$

41652952556.  $384 \text{ ms}^{-1}$

41652952557.  $332 \text{ ms}^{-1}$

Question Number : 29 Question Id : 41652913444 Question Type : MCQ Option Shuffling : Yes Display Question Number : Yes  
Single Line Question Option : No Option Orientation : Vertical

Correct Marks : 4 Wrong Marks : 1



अनुनाद नली विधि द्वारा वायु में ध्वनि की चाल ( $v$ ) ज्ञात करने के लिये एक प्रयोग में 480 Hz आवृत्ति के स्वरित्र का उपयोग करते हैं। वायु स्तम्भ की दो उत्तरोत्तर लम्बाइयों  $l_1 = 30$  cm तथा  $l_2 = 70$  cm के लिये अनुनाद प्राप्त होते हैं। तब  $v$  का मान है :

Options :

41652952554.  $338 \text{ ms}^{-1}$

41652952555.  $379 \text{ ms}^{-1}$

41652952556.  $384 \text{ ms}^{-1}$

41652952557.  $332 \text{ ms}^{-1}$

Question Number : 30 Question Id : 41652913445 Question Type : MCQ Option Shuffling : Yes Display Question Number : Yes  
Single Line Question Option : No Option Orientation : Vertical

Correct Marks : 4 Wrong Marks : 1

A moving coil galvanometer, having a resistance  $G$ , produces full scale deflection when a current  $I_g$  flows through it. This galvanometer can be converted into (i) an ammeter of range 0 to  $I_0$  ( $I_0 > I_g$ ) by connecting a shunt resistance  $R_A$  to it and (ii) into a voltmeter of range 0 to  $V$  ( $V = GI_0$ ) by connecting a series resistance  $R_V$  to it. Then,

Options :

41652952558.  $R_A R_V = G^2$  and  $\frac{R_A}{R_V} = \left( \frac{I_g}{I_0 - I_g} \right)^2$

41652952559.  $R_A R_V = G^2$  and  $\frac{R_A}{R_V} = \frac{I_g}{(I_0 - I_g)}$

$R_A R_V = G^2 \left( \frac{I_g}{I_0 - I_g} \right)$  and

41652952560.  $\frac{R_A}{R_V} = \left( \frac{I_0 - I_g}{I_g} \right)^2$

$$R_A R_V = G^2 \left( \frac{I_0 - I_g}{I_g} \right) \text{ and}$$

$$\frac{R_A}{R_V} = \left( \frac{I_g}{I_0 - I_g} \right)^2$$

41652952561.

Question Number : 30 Question Id : 41652913445 Question Type : MCQ Option Shuffling : Yes Display Question Number : Yes  
Single Line Question Option : No Option Orientation : Vertical

Correct Marks : 4 Wrong Marks : 1

प्रतिरोध  $G$  के एक चल कुंडली धारामापी में धारा  $I_g$  पर पूर्ण विक्षेप पाया जाता है। इस धारामापी को परास 0 से  $I_0$  ( $I_0 > I_g$ ) धारा के अमीटर में एक शंट प्रतिरोध  $R_A$  लगाकर परिवर्तित कर सकते हैं। इसी धारामापी को परास 0 से  $V$  ( $V = GI_0$ ) के वोल्टमीटर में एक श्रेणी प्रतिरोध  $R_V$  लगाकर परिवर्तित कर सकते हैं। तो :

Options :

$$R_A R_V = G^2 \text{ तथा } \frac{R_A}{R_V} = \left( \frac{I_g}{I_0 - I_g} \right)^2$$

41652952558.

$$R_A R_V = G^2 \text{ तथा } \frac{R_A}{R_V} = \frac{I_g}{I_0 - I_g}$$

41652952559.

$$R_A R_V = G^2 \left( \frac{I_g}{I_0 - I_g} \right) \text{ तथा}$$

$$\frac{R_A}{R_V} = \left( \frac{I_0 - I_g}{I_g} \right)^2$$

41652952560.

$$R_A R_V = G^2 \left( \frac{I_0 - I_g}{I_g} \right) \text{ तथा}$$

$$\frac{R_A}{R_V} = \left( \frac{I_g}{I_0 - I_g} \right)^2$$

41652952561.

Section Id :

Section Number :

Section type :

Chemistry

416529275

2

Online

Mandatory or Optional:	Mandatory
Number of Questions:	30
Number of Questions to be attempted:	30
Section Marks:	120
Display Number Panel:	Yes
Group All Questions:	No

Sub-Section Number:	1
Sub-Section Id:	416529415
Question Shuffling Allowed :	Yes

Question Number : 31 Question Id : 41652913446 Question Type : MCQ Option Shuffling : Yes Display Question Number : Yes  
Single Line Question Option : No Option Orientation : Vertical

Correct Marks : 4 Wrong Marks : 1

In the following skew conformation of ethane,  $H' - C - C - H''$  dihedral angle is :

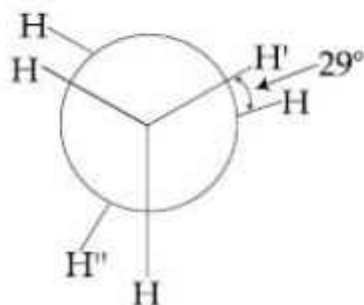

Options :

41652952562.  $58^\circ$
41652952563.  $151^\circ$
41652952564.  $149^\circ$
41652952565.  $120^\circ$

Question Number : 31 Question Id : 41652913446 Question Type : MCQ Option Shuffling : Yes Display Question Number : Yes  
Single Line Question Option : No Option Orientation : Vertical

Correct Marks : 4 Wrong Marks : 1

एथेन के निम्न विषमतलीय संरूपण में,  
 $H' - C - C - H''$  द्वितल कोण है :

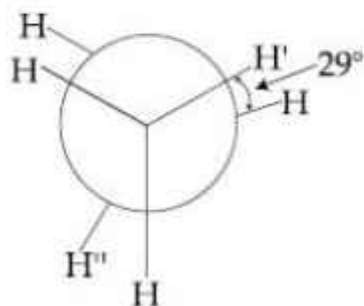

Options :

41652952562. 58°  
41652952563. 151°  
41652952564. 149°  
41652952565. 120°

Question Number : 32 Question Id : 41652913447 Question Type : MCQ Option Shuffling : Yes Display Question Number : Yes  
Single Line Question Option : No Option Orientation : Vertical  
Correct Marks : 4 Wrong Marks : 1

The IUPAC name for the following compound is :

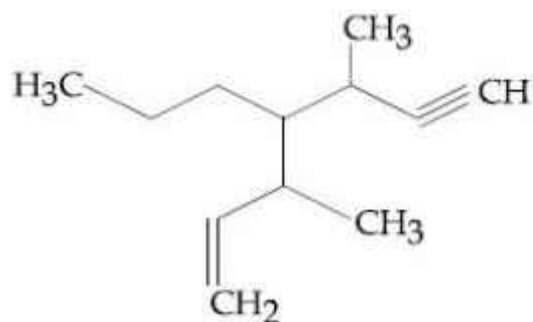

Options :

41652952566. 3,5-dimethyl-4-propylhept-6-en-1-yne  
41652952567. 3-methyl-4-(3-methylprop-1-enyl)-1-heptyne  
41652952568. 3,5-dimethyl-4-propylhept-1-en-6-yne  
41652952569. 3-methyl-4-(1-methylprop-2-ynyl)-1-heptene

Question Number : 32 Question Id : 41652913447 Question Type : MCQ Option Shuffling : Yes Display Question Number : Yes  
Single Line Question Option : No Option Orientation : Vertical  
Correct Marks : 4 Wrong Marks : 1

निम्न यौगिक के लिए IUPAC नाम है :

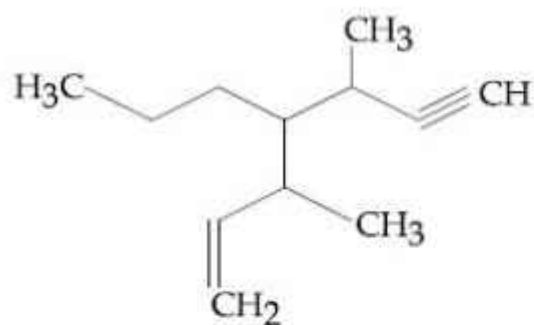

Options :

41652952566. 3,5-डाइमेथिल-4-प्रोपिलहेप्ट-6-ईन-1-आइन

41652952567. 3-मेथिल-4-(3-मेथिलप्रोप-1-इनिल)-1-हेप्टाइन

41652952568. 3,5-डाइमेथिल-4-प्रोपिलहेप्ट-1-ईन-6-आइन

41652952569. 3-मेथिल-4-(1-मेथिलप्रोप-2-आयनिल)-1-हेप्टीन

Question Number : 33 Question Id : 41652913448 Question Type : MCQ Option Shuffling : Yes Display Question Number : Yes  
Single Line Question Option : No Option Orientation : Vertical  
Correct Marks : 4 Wrong Marks : 1

Consider the following reactions :

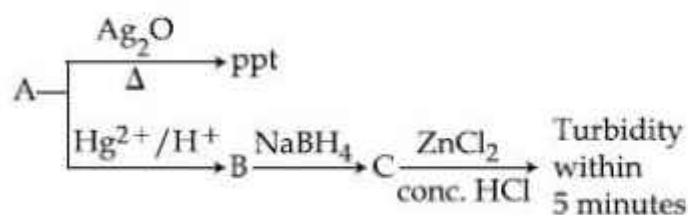

'A' is :

Options :

41652952570.  $\text{CH} \equiv \text{CH}$

41652952571.  $\text{CH}_3 - \text{C} \equiv \text{CH}$

41652952572.  $\text{CH}_3 - \text{C} \equiv \text{C} - \text{CH}_3$

41652952573.  $\text{CH}_2 = \text{CH}_2$

Question Number : 33 Question Id : 41652913448 Question Type : MCQ Option Shuffling : Yes Display Question Number : Yes  
Single Line Question Option : No Option Orientation : Vertical

Correct Marks : 4 Wrong Marks : 1

निम्न अभिक्रियाओं पर विचार कीजिए :

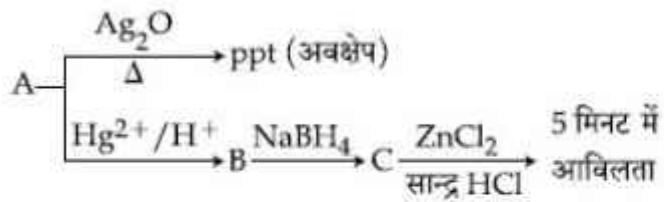

'A' है :

Options :

41652952570.  $\text{CH} \equiv \text{CH}$

41652952571.  $\text{CH}_3 - \text{C} \equiv \text{CH}$

41652952572.  $\text{CH}_3 - \text{C} \equiv \text{C} - \text{CH}_3$

41652952573.  $\text{CH}_2 = \text{CH}_2$

Question Number : 34 Question Id : 41652913449 Question Type : MCQ Option Shuffling : Yes Display Question Number : Yes  
Single Line Question Option : No Option Orientation : Vertical

Correct Marks : 4 Wrong Marks : 1

Which of the given statements is INCORRECT about glycogen ?

Options :

41652952574. It is present in animal cells.

41652952575. It is a straight chain polymer similar to amylose.

41652952576. It is present in some yeast and fungi.

41652952577. Only  $\alpha$ -linkages are present in the molecule.

Question Number : 34 Question Id : 41652913449 Question Type : MCQ Option Shuffling : Yes Display Question Number : Yes  
Single Line Question Option : No Option Orientation : Vertical

Correct Marks : 4 Wrong Marks : 1

ग्लायकोजेन के सम्बन्ध में दिये गये कथनों में से कौन सा सही नहीं है?

Options :

41652952574. यह प्राणी-कोषिकाओं में उपस्थित है।

41652952575. एमिलोज की तरह यह एक ऋजुशृंखल बहुलक है।

41652952576. यह कुछ यीस्ट (खमीर) तथा कवकों में उपस्थित है।

41652952577. अणुओं में मात्र  $\alpha$ -बंधन उपस्थित हैं।

Question Number : 35 Question Id : 41652913450 Question Type : MCQ Option Shuffling : Yes Display Question Number : Yes  
Single Line Question Option : No Option Orientation : Vertical  
Correct Marks : 4 Wrong Marks : 1

The correct name of the following polymer is :

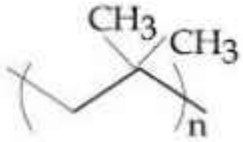

Options :

41652952578. Polyisobutane

41652952579. Polyisobutylene

41652952580. Polytert-butylene

41652952581. Polyisoprene

Question Number : 35 Question Id : 41652913450 Question Type : MCQ Option Shuffling : Yes Display Question Number : Yes  
Single Line Question Option : No Option Orientation : Vertical  
Correct Marks : 4 Wrong Marks : 1

निम्न बहुलक का सही नाम है :

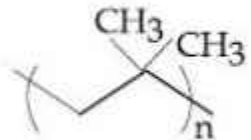

Options :

41652952578. पालीआइसोब्यूटेन

41652952579. पालीआइसोब्यूटाइलीन

पालीटर्ट-ब्यूटाइलीन

41652952580.

पालीआइसोप्रीन

41652952581.

Question Number : 36 Question Id : 41652913451 Question Type : MCQ Option Shuffling : Yes Display Question Number : Yes  
Single Line Question Option : No Option Orientation : Vertical

Correct Marks : 4 Wrong Marks : 1

Benzene diazonium chloride on reaction with aniline in the presence of dilute hydrochloric acid gives :

Options :

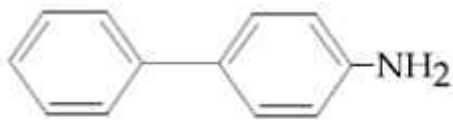
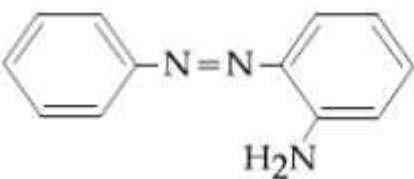
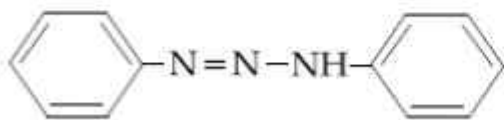
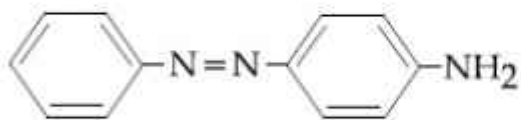

Question Number : 36 Question Id : 41652913451 Question Type : MCQ Option Shuffling : Yes Display Question Number : Yes  
Single Line Question Option : No Option Orientation : Vertical

Correct Marks : 4 Wrong Marks : 1

तनु हाइड्रोक्लोरिक अम्ल की उपस्थिति में बेंजीन डाइजोनियम क्लोराइड, एनिलीन के साथ अभिक्रिया करके देता है :

Options :

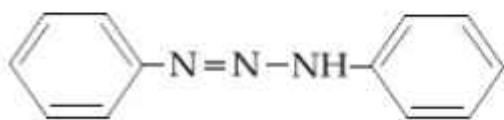
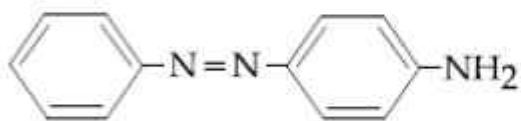



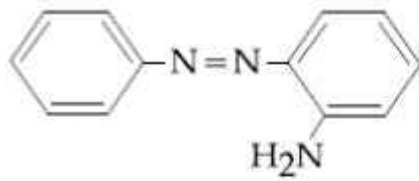

41652952584.

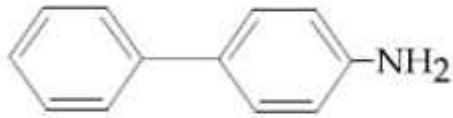

41652952585.

Question Number : 37 Question Id : 41652913452 Question Type : MCQ Option Shuffling : Yes Display Question Number : Yes  
Single Line Question Option : No Option Orientation : Vertical

Correct Marks : 4 Wrong Marks : 1

Heating of 2-chloro-1-phenylbutane with EtOK/EtOH gives X as the major product. Reaction of X with  $\text{Hg}(\text{OAc})_2/\text{H}_2\text{O}$  followed by  $\text{NaBH}_4$  gives Y as the major product. Y is :

Options :

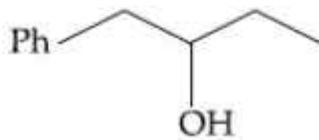

41652952586.

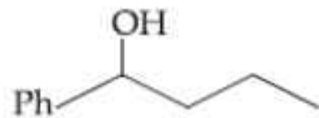

41652952587.



41652952588.

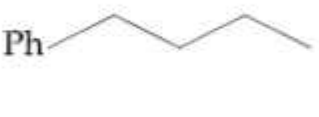

41652952589.

Question Number : 37 Question Id : 41652913452 Question Type : MCQ Option Shuffling : Yes Display Question Number : Yes  
Single Line Question Option : No Option Orientation : Vertical

Correct Marks : 4 Wrong Marks : 1

2-क्लोरो-1-फेनिलब्यूटेन को EtOK/EtOH के साथ गरम करने पर X मुख्य उत्पाद के रूप में प्राप्त होता है।  $\text{Hg}(\text{OAc})_2/\text{H}_2\text{O}$  के साथ X की अभिक्रिया तत्पश्चात्  $\text{NaBH}_4$  के साथ अभिक्रिया से प्राप्त Y मुख्य उत्पाद है। Y है :

Options :

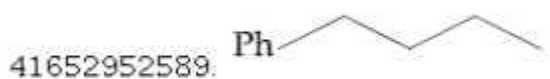
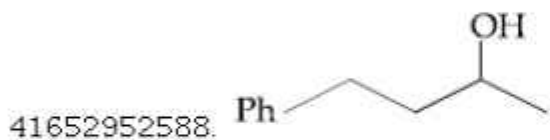
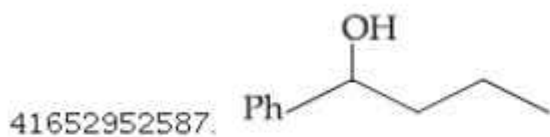
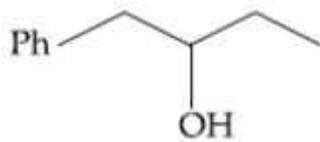

Question Number : 38 Question Id : 41652913453 Question Type : MCQ Option Shuffling : Yes Display Question Number : Yes  
Single Line Question Option : No Option Orientation : Vertical

Correct Marks : 4 Wrong Marks : 1

What will be the major product when m-cresol is reacted with propargyl bromide ( $\text{HC}\equiv\text{C}-\text{CH}_2\text{Br}$ ) in presence of  $\text{K}_2\text{CO}_3$  in acetone ?

Options :

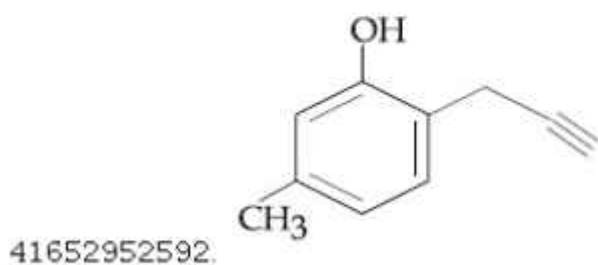
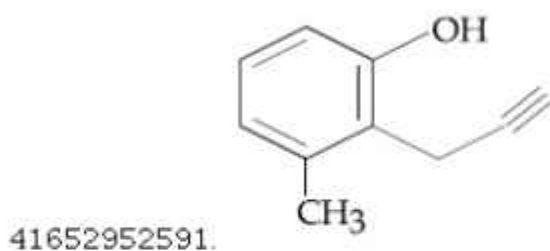
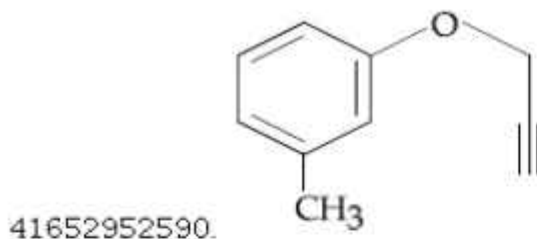

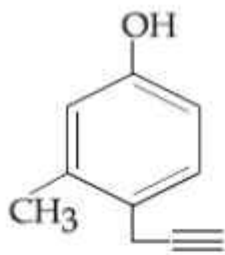

41652952593.

Question Number : 38 Question Id : 41652913453 Question Type : MCQ Option Shuffling : Yes Display Question Number : Yes  
Single Line Question Option : No Option Orientation : Vertical

Correct Marks : 4 Wrong Marks : 1

मुख्य उत्पाद क्या होगा जब m-क्रिसॉल को एसीटोन में  $K_2CO_3$  की उपस्थिति में प्रोपर्जिल ब्रोमाइड ( $HC \equiv C-CH_2Br$ ) के साथ अभिकृत किया जाता है?

Options :

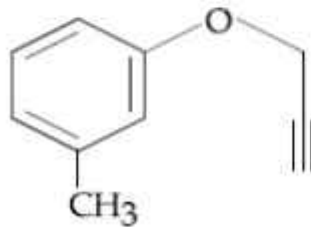

41652952590.

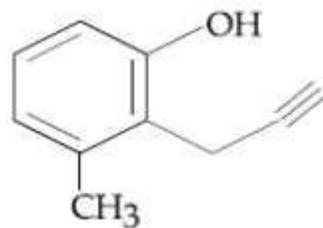

41652952591.

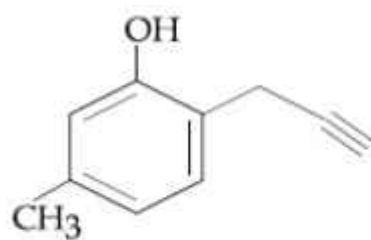

41652952592.

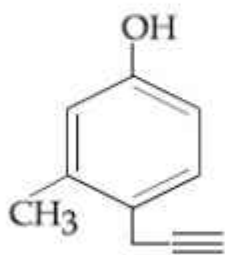

41652952593.

Question Number : 39 Question Id : 41652913454 Question Type : MCQ Option Shuffling : Yes Display Question Number : Yes  
Single Line Question Option : No Option Orientation : Vertical

Correct Marks : 4 Wrong Marks : 1

An 'Assertion' and a 'Reason' are given below. Choose the correct answer from the following options :

**Assertion (A):** Vinyl halides do not undergo nucleophilic substitution easily.

**Reason (R):** Even though the intermediate carbocation is stabilized by loosely held  $\pi$ -electrons, the cleavage is difficult because of strong bonding.

Options :

41652952594. Both (A) and (R) are correct statements and (R) is the correct explanation of (A).

41652952595. Both (A) and (R) are correct statements but (R) is not the correct explanation of (A).

41652952596. (A) is a correct statement but (R) is a wrong statement.

41652952597. Both (A) and (R) are wrong statements.

Question Number : 39 Question Id : 41652913454 Question Type : MCQ Option Shuffling : Yes Display Question Number : Yes  
Single Line Question Option : No Option Orientation : Vertical

Correct Marks : 4 Wrong Marks : 1

एक 'कथन' तथा एक 'कारण' नीचे दिया गया है।

निम्न विकल्पों में से सही उत्तर का चुनाव कीजिए :

**कथन (A):** विनाइल हैलाइड का नाभिकरागी प्रतिस्थापन आसानी से नहीं होता।

**कारण (R):** अदृढ़  $\pi$ -इलेक्ट्रॉनों द्वारा मध्यवर्ती कार्बोकैटायन के स्थायित्व के बावजूद भी, प्रबल आबंधन के कारण विदलन कठिन है।

Options :

41652952594. (A) तथा (R) दोनों सही हैं तथा (R), (A) की सही व्याख्या है।

41652952595. (A) तथा (R) दोनों सही हैं परन्तु (R), (A) की सही व्याख्या नहीं है।

41652952596. (A) सही है परन्तु (R) गलत है।

41652952597. (A) तथा (R) दोनों ही गलत हैं।

Question Number : 40 Question Id : 41652913455 Question Type : MCQ Option Shuffling : Yes Display Question Number : Yes  
Single Line Question Option : No Option Orientation : Vertical

Correct Marks : 4 Wrong Marks : 1

Which one of the following is likely to give a precipitate with  $\text{AgNO}_3$  solution ?

Options :

41652952598.  $\text{CCl}_4$

41652952599.  $\text{CHCl}_3$

41652952600.  $(\text{CH}_3)_3\text{CCl}$

41652952601.  $\text{CH}_2=\text{CH}-\text{Cl}$

Question Number : 40 Question Id : 41652913455 Question Type : MCQ Option Shuffling : Yes Display Question Number : Yes  
Single Line Question Option : No Option Orientation : Vertical

Correct Marks : 4 Wrong Marks : 1

निम्न में से किसकी  $\text{AgNO}_3$  विलयन के साथ अवक्षेप देने की संभावना है?

Options :

41652952598.  $\text{CCl}_4$

41652952599.  $\text{CHCl}_3$

41652952600.  $(\text{CH}_3)_3\text{CCl}$

41652952601.  $\text{CH}_2=\text{CH}-\text{Cl}$

Question Number : 41 Question Id : 41652913456 Question Type : MCQ Option Shuffling : Yes Display Question Number : Yes  
Single Line Question Option : No Option Orientation : Vertical

Correct Marks : 4 Wrong Marks : 1

In comparison to boron, beryllium has :

Options :

41652952602. greater nuclear charge and greater first ionisation enthalpy.

lesser nuclear charge and greater first ionisation enthalpy.

41652952603.

lesser nuclear charge and lesser first ionisation enthalpy.

41652952604.

greater nuclear charge and lesser first ionisation enthalpy.

41652952605.

Question Number : 41 Question Id : 41652913456 Question Type : MCQ Option Shuffling : Yes Display Question Number : Yes Single Line Question Option : No Option Orientation : Vertical

Correct Marks : 4 Wrong Marks : 1

बोरान की तुलना में बेरीलियम रखता है :

Options :

उच्चतर नाभिकीय आवेश तथा उच्चतर प्रथम आयनन एन्थैल्पी।

41652952602.

निम्नतर नाभिकीय आवेश तथा उच्चतर प्रथम आयनन एन्थैल्पी।

41652952603.

निम्नतर नाभिकीय आवेश तथा निम्नतर प्रथम आयनन एन्थैल्पी।

41652952604.

उच्चतर नाभिकीय आवेश तथा निम्नतर प्रथम आयनन एन्थैल्पी।

41652952605.

Question Number : 42 Question Id : 41652913457 Question Type : MCQ Option Shuffling : Yes Display Question Number : Yes Single Line Question Option : No Option Orientation : Vertical

Correct Marks : 4 Wrong Marks : 1

The correct statement is :

Options :

the blistered appearance of copper during the metallurgical process is due to the evolution of  $\text{CO}_2$ .

41652952606.

pig iron is obtained from cast iron.

41652952607.

leaching of bauxite using concentrated NaOH solution gives sodium aluminate and sodium silicate.

41652952608.

the Hall-Heroult process is used for the production of aluminium and iron.

41652952609.

Question Number : 42 Question Id : 41652913457 Question Type : MCQ Option Shuffling : Yes Display Question Number : Yes Single Line Question Option : No Option Orientation : Vertical

Correct Marks : 4 Wrong Marks : 1

सही कथन है :

Options :

धात्विक प्रक्रम के बीच कॉपर का ब्लिस्टर्ड रूप  $\text{CO}_2$  के निर्गमन के कारण होता है।

41652952606.

कास्ट आयरन (ढलवालोहा) से पिग आयरन(कच्चा लोहा) प्राप्त किया जाता है।

41652952607.

सान्द्र NaOH विलयन का प्रयोग करते हुये बाक्साइट का निश्चालन सोडियम एलुमीनेट तथा सोडियम सिलीकेट देता है।

41652952608.

एलुमीनियम तथा आयरन के उत्पादन के लिए हाल-हेराल्ट प्रक्रम प्रयुक्त होता है।

41652952609.

Question Number : 43 Question Id : 41652913458 Question Type : MCQ Option Shuffling : Yes Display Question Number : Yes Single Line Question Option : No Option Orientation : Vertical

Correct Marks : 4 Wrong Marks : 1

The temporary hardness of a water sample is due to compound X. Boiling this sample converts X to compound Y. X and Y, respectively, are :

Options :

$\text{Mg}(\text{HCO}_3)_2$  and  $\text{Mg}(\text{OH})_2$

41652952610.

$\text{Mg}(\text{HCO}_3)_2$  and  $\text{MgCO}_3$

41652952611.

$\text{Ca}(\text{HCO}_3)_2$  and  $\text{Ca}(\text{OH})_2$

41652952612.

41652952613.  $\text{Ca}(\text{HCO}_3)_2$  and  $\text{CaO}$

Question Number : 43 Question Id : 41652913458 Question Type : MCQ Option Shuffling : Yes Display Question Number : Yes  
Single Line Question Option : No Option Orientation : Vertical

Correct Marks : 4 Wrong Marks : 1

जल प्रतिदर्श की अस्थायी कठोरता यौगिक X के कारण है। इस प्रतिदर्श को उबालने पर X बदलकर यौगिक Y हो जाता है। X तथा Y, क्रमशः, हैं :

Options :

41652952610.  $\text{Mg}(\text{HCO}_3)_2$  तथा  $\text{Mg}(\text{OH})_2$

41652952611.  $\text{Mg}(\text{HCO}_3)_2$  तथा  $\text{MgCO}_3$

41652952612.  $\text{Ca}(\text{HCO}_3)_2$  तथा  $\text{Ca}(\text{OH})_2$

41652952613.  $\text{Ca}(\text{HCO}_3)_2$  तथा  $\text{CaO}$

Question Number : 44 Question Id : 41652913459 Question Type : MCQ Option Shuffling : Yes Display Question Number : Yes  
Single Line Question Option : No Option Orientation : Vertical

Correct Marks : 4 Wrong Marks : 1

The INCORRECT statement is :

Options :

41652952614.  $\text{LiNO}_3$  decomposes on heating to give  $\text{LiNO}_2$  and  $\text{O}_2$ .

41652952615. Lithium is the strongest reducing agent among the alkali metals.

41652952616. Lithium is least reactive with water among the alkali metals.

41652952617.  $\text{LiCl}$  crystallises from aqueous solution as  $\text{LiCl} \cdot 2\text{H}_2\text{O}$ .

Question Number : 44 Question Id : 41652913459 Question Type : MCQ Option Shuffling : Yes Display Question Number : Yes  
Single Line Question Option : No Option Orientation : Vertical

Correct Marks : 4 Wrong Marks : 1

गलत कथन है :

Options :



$\text{LiNO}_3$  गरम करने पर अपघटित होकर  $\text{LiNO}_2$  तथा  $\text{O}_2$  देता है।

41652952614.

क्षार धातुओं में लीथियम प्रबलतम अपचायी कर्मक है।

41652952615.

क्षार धातुओं में लीथियम जल के साथ सबसे कम अभिक्रियाशील है।

41652952616.

$\text{LiCl}$  जलीय विलयन से  $\text{LiCl} \cdot 2\text{H}_2\text{O}$  के रूप में क्रिस्टलित होता है।

41652952617.

Question Number : 45 Question Id : 41652913460 Question Type : MCQ Option Shuffling : Yes Display Question Number : Yes Single Line Question Option : No Option Orientation : Vertical

Correct Marks : 4 Wrong Marks : 1

The C – C bond length is maximum in :

Options :

41652952618.  $\text{C}_{60}$

41652952619. graphite

41652952620. diamond

41652952621.  $\text{C}_{70}$

Question Number : 45 Question Id : 41652913460 Question Type : MCQ Option Shuffling : Yes Display Question Number : Yes Single Line Question Option : No Option Orientation : Vertical

Correct Marks : 4 Wrong Marks : 1

निम्न में से किसमें C – C आबन्ध लम्बाई अधिकतम है?

Options :

41652952618.  $\text{C}_{60}$

41652952619. ग्रेफाइट

41652952620. हीरा ( डायमंड)

41652952621.  $\text{C}_{70}$

Question Number : 46 Question Id : 41652913461 Question Type : MCQ Option Shuffling : Yes Display Question Number : Yes  
Single Line Question Option : No Option Orientation : Vertical

Correct Marks : 4 Wrong Marks : 1

Thermal decomposition of a Mn compound (X) at 513 K results in compound Y,  $\text{MnO}_2$  and a gaseous product.  $\text{MnO}_2$  reacts with NaCl and concentrated  $\text{H}_2\text{SO}_4$  to give a pungent gas Z. X, Y, and Z, respectively, are :

Options :

41652952622.  $\text{K}_2\text{MnO}_4$ ,  $\text{KMnO}_4$  and  $\text{SO}_2$

41652952623.  $\text{KMnO}_4$ ,  $\text{K}_2\text{MnO}_4$  and  $\text{Cl}_2$

41652952624.  $\text{K}_2\text{MnO}_4$ ,  $\text{KMnO}_4$  and  $\text{Cl}_2$

41652952625.  $\text{K}_3\text{MnO}_4$ ,  $\text{K}_2\text{MnO}_4$  and  $\text{Cl}_2$

Question Number : 46 Question Id : 41652913461 Question Type : MCQ Option Shuffling : Yes Display Question Number : Yes  
Single Line Question Option : No Option Orientation : Vertical

Correct Marks : 4 Wrong Marks : 1

513 K पर, एक Mn यौगिक (X) के तापीय अपघटन से यौगिक Y,  $\text{MnO}_2$  तथा एक गैसीय उत्पाद प्राप्त होता है। NaCl तथा सान्द्र  $\text{H}_2\text{SO}_4$  से  $\text{MnO}_2$  अभिक्रिया करके एक तीखी गैस Z देता है। X, Y तथा Z क्रमशः हैं :

Options :

41652952622.  $\text{K}_2\text{MnO}_4$ ,  $\text{KMnO}_4$  तथा  $\text{SO}_2$

41652952623.  $\text{KMnO}_4$ ,  $\text{K}_2\text{MnO}_4$  तथा  $\text{Cl}_2$

41652952624.  $\text{K}_2\text{MnO}_4$ ,  $\text{KMnO}_4$  तथा  $\text{Cl}_2$

41652952625.  $\text{K}_3\text{MnO}_4$ ,  $\text{K}_2\text{MnO}_4$  तथा  $\text{Cl}_2$

Question Number : 47 Question Id : 41652913462 Question Type : MCQ Option Shuffling : Yes Display Question Number : Yes  
Single Line Question Option : No Option Orientation : Vertical

Correct Marks : 4 Wrong Marks : 1

The pair that has similar atomic radii is :

Options :

41652952626. Ti and Hf

41652952627. Mn and Re

41652952628. Sc and Ni

41652952629. Mo and W

Question Number : 47 Question Id : 41652913462 Question Type : MCQ Option Shuffling : Yes Display Question Number : Yes  
Single Line Question Option : No Option Orientation : Vertical

Correct Marks : 4 Wrong Marks : 1

वह युग्म जिसकी परमाण्विक त्रिन्यायें एक जैसी हैं,  
होगा :

Options :

41652952626. Ti तथा Hf

41652952627. Mn तथा Re

41652952628. Sc तथा Ni

41652952629. Mo तथा W

Question Number : 48 Question Id : 41652913463 Question Type : MCQ Option Shuffling : Yes Display Question Number : Yes  
Single Line Question Option : No Option Orientation : Vertical

Correct Marks : 4 Wrong Marks : 1

The compound used in the treatment of  
lead poisoning is :

Options :

41652952630. D-penicillamine

41652952631. EDTA

41652952632. Cis-platin

41652952633. desferrioxime B

Question Number : 48 Question Id : 41652913463 Question Type : MCQ Option Shuffling : Yes Display Question Number : Yes  
Single Line Question Option : No Option Orientation : Vertical

Correct Marks : 4 Wrong Marks : 1

लेड विषकृता के उपचार में प्रयुक्त यौगिक है :

Options :

41652952630. D-पेनीसिलामाइन

41652952631. EDTA

41652952632. सिस-प्लेटिन

41652952633. डेसफेरीआक्साइम B

Question Number : 49 Question Id : 41652913464 Question Type : MCQ Option Shuffling : Yes Display Question Number : Yes  
Single Line Question Option : No Option Orientation : Vertical

Correct Marks : 4 Wrong Marks : 1

The coordination numbers of Co and Al in  
[Co(Cl)(en)<sub>2</sub>]Cl and K<sub>3</sub>[Al(C<sub>2</sub>O<sub>4</sub>)<sub>3</sub>],  
respectively, are :

(en = ethane-1, 2-diamine)

Options :

41652952634. 6 and 6

41652952635. 3 and 3

41652952636. 5 and 6

41652952637. 5 and 3

Question Number : 49 Question Id : 41652913464 Question Type : MCQ Option Shuffling : Yes Display Question Number : Yes  
Single Line Question Option : No Option Orientation : Vertical

Correct Marks : 4 Wrong Marks : 1

[Co(Cl)(en)<sub>2</sub>]Cl तथा K<sub>3</sub>[Al(C<sub>2</sub>O<sub>4</sub>)<sub>3</sub>] में Co  
तथा Al की उपसहसंयोजन संख्यायें, क्रमशः, हैं :

(en = एथेन-1, 2-डाइएमीन)

Options :

41652952634. 6 तथा 6

41652952635. 3 तथा 3

41652952636. 5 तथा 6

41652952637. 5 तथा 3

Question Number : 50 Question Id : 41652913465 Question Type : MCQ Option Shuffling : Yes Display Question Number : Yes  
Single Line Question Option : No Option Orientation : Vertical

Correct Marks : 4 Wrong Marks : 1

The primary pollutant that leads to photochemical smog is :

Options :

41652952638. ozone
41652952639. sulphur dioxide
41652952640. acrolein
41652952641. nitrogen oxides

Question Number : 50 Question Id : 41652913465 Question Type : MCQ Option Shuffling : Yes Display Question Number : Yes  
Single Line Question Option : No Option Orientation : Vertical

Correct Marks : 4 Wrong Marks : 1

प्राथमिक प्रदूषक जो प्रकाशरासायनिक धूमकुहा पैदा करता है, है :

Options :

41652952638. ओजोन
41652952639. सल्फर डाइऑक्साइड
41652952640. एक्रोलीन
41652952641. नाइट्रोजन ऑक्साइडें

Question Number : 51 Question Id : 41652913466 Question Type : MCQ Option Shuffling : Yes Display Question Number : Yes  
Single Line Question Option : No Option Orientation : Vertical

Correct Marks : 4 Wrong Marks : 1

25 g of an unknown hydrocarbon upon burning produces 88 g of  $\text{CO}_2$  and 9 g of  $\text{H}_2\text{O}$ . This unknown hydrocarbon contains :

Options :

41652952642. 20 g of carbon and 5 g of hydrogen
41652952643. 24 g of carbon and 1 g of hydrogen
41652952644. 22 g of carbon and 3 g of hydrogen

41652952645. 18 g of carbon and 7 g of hydrogen

Question Number : 51 Question Id : 41652913466 Question Type : MCQ Option Shuffling : Yes Display Question Number : Yes  
Single Line Question Option : No Option Orientation : Vertical

Correct Marks : 4 Wrong Marks : 1

एक अज्ञात हाइड्रोकार्बन के 25 g को जलाने पर 88 g  $\text{CO}_2$  तथा 9 g  $\text{H}_2\text{O}$  उत्पन्न होते हैं। इस अज्ञात हाइड्रोकार्बन में ये सन्निहित हैं,

Options :

41652952642. 20 g कार्बन तथा 5 g हाइड्रोजन

41652952643. 24 g कार्बन तथा 1 g हाइड्रोजन

41652952644. 22 g कार्बन तथा 3 g हाइड्रोजन

41652952645. 18 g कार्बन तथा 7 g हाइड्रोजन

Question Number : 52 Question Id : 41652913467 Question Type : MCQ Option Shuffling : Yes Display Question Number : Yes  
Single Line Question Option : No Option Orientation : Vertical

Correct Marks : 4 Wrong Marks : 1

The ratio of number of atoms present in a simple cubic, body centered cubic and face centered cubic structure are, respectively :

Options :

41652952646. 8 : 1 : 6

41652952647. 1 : 2 : 4

41652952648. 4 : 2 : 3

41652952649. 4 : 2 : 1

Question Number : 52 Question Id : 41652913467 Question Type : MCQ Option Shuffling : Yes Display Question Number : Yes  
Single Line Question Option : No Option Orientation : Vertical

Correct Marks : 4 Wrong Marks : 1

सरल घनीय, अंतःकेन्द्रित घनीय तथा फलक केन्द्रित घनीय संरचना में उपस्थित परमाणुओं की संख्या का अनुपात क्रमशः, होगा :

Options :

41652952646. 8 : 1 : 6

41652952647. 1 : 2 : 4

41652952648. 4 : 2 : 3

41652952649. 4 : 2 : 1

Question Number : 53 Question Id : 41652913468 Question Type : MCQ Option Shuffling : Yes Display Question Number : Yes  
Single Line Question Option : No Option Orientation : Vertical

Correct Marks : 4 Wrong Marks : 1

Among the following, the energy of 2s orbital is lowest in :

Options :

41652952650. H

41652952651. K

41652952652. Na

41652952653. Li

Question Number : 53 Question Id : 41652913468 Question Type : MCQ Option Shuffling : Yes Display Question Number : Yes  
Single Line Question Option : No Option Orientation : Vertical

Correct Marks : 4 Wrong Marks : 1

निम्न में, 2s कक्षक की ऊर्जा किसमें निम्नतम है ?

Options :

41652952650. H

41652952651. K

41652952652. Na

41652952653. Li

Question Number : 54 Question Id : 41652913469 Question Type : MCQ Option Shuffling : Yes Display Question Number : Yes  
Single Line Question Option : No Option Orientation : Vertical

Correct Marks : 4 Wrong Marks : 1

The INCORRECT match in the following is :

Options :

41652952654.  $\Delta G^0 < 0, K > 1$

41652952655.  $\Delta G^0 < 0, K < 1$

41652952656.  $\Delta G^0 > 0, K < 1$

41652952657.  $\Delta G^0 = 0, K = 1$

Question Number : 54 Question Id : 41652913469 Question Type : MCQ Option Shuffling : Yes Display Question Number : Yes  
Single Line Question Option : No Option Orientation : Vertical

Correct Marks : 4 Wrong Marks : 1

निम्न में गलत मिलान किसमें है?

Options :

41652952654.  $\Delta G^0 < 0, K > 1$

41652952655.  $\Delta G^0 < 0, K < 1$

41652952656.  $\Delta G^0 > 0, K < 1$

41652952657.  $\Delta G^0 = 0, K = 1$

Question Number : 55 Question Id : 41652913470 Question Type : MCQ Option Shuffling : Yes Display Question Number : Yes  
Single Line Question Option : No Option Orientation : Vertical

Correct Marks : 4 Wrong Marks : 1

A solution is prepared by dissolving 0.6 g of urea (molar mass =  $60 \text{ g mol}^{-1}$ ) and 1.8 g of glucose (molar mass =  $180 \text{ g mol}^{-1}$ ) in 100 mL of water at  $27^\circ\text{C}$ . The osmotic pressure of the solution is :

( $R = 0.08206 \text{ L atm K}^{-1} \text{ mol}^{-1}$ )

Options :

41652952658. 4.92 atm

41652952659. 2.46 atm

41652952660. 1.64 atm

41652952661. 8.2 atm

Question Number : 55 Question Id : 41652913470 Question Type : MCQ Option Shuffling : Yes Display Question Number : Yes  
Single Line Question Option : No Option Orientation : Vertical

Correct Marks : 4 Wrong Marks : 1



27 °C पर, एक विलयन को 100 mL जल में 0.6 g यूरिया (मोलर द्रव्यमान = 60 g mol<sup>-1</sup>) तथा 1.8 g ग्लूकोज (मोलर द्रव्यमान = 180 g mol<sup>-1</sup>) घोलकर तैयार किया गया। विलयन का परासरण दाब होगा :  
(R = 0.08206 L atm K<sup>-1</sup> mol<sup>-1</sup>)

Options :

41652952658. 4.92 atm

41652952659. 2.46 atm

41652952660. 1.64 atm

41652952661. 8.2 atm

Question Number : 56 Question Id : 41652913471 Question Type : MCQ Option Shuffling : Yes Display Question Number : Yes  
Single Line Question Option : No Option Orientation : Vertical  
Correct Marks : 4 Wrong Marks : 1

In which one of the following equilibria,

$K_p \neq K_c$  ?

Options :

41652952662.  $\text{NO}_2(\text{g}) + \text{SO}_2(\text{g}) = \text{NO}(\text{g}) + \text{SO}_3(\text{g})$

41652952663.  $2\text{HI}(\text{g}) = \text{H}_2(\text{g}) + \text{I}_2(\text{g})$

41652952664.  $2\text{C}(\text{s}) + \text{O}_2(\text{g}) = 2\text{CO}(\text{g})$

41652952665.  $2\text{NO}(\text{g}) = \text{N}_2(\text{g}) + \text{O}_2(\text{g})$

Question Number : 56 Question Id : 41652913471 Question Type : MCQ Option Shuffling : Yes Display Question Number : Yes  
Single Line Question Option : No Option Orientation : Vertical  
Correct Marks : 4 Wrong Marks : 1

निम्न किस एक साम्य में  $K_p \neq K_c$  है?

Options :

41652952662.  $\text{NO}_2(\text{g}) + \text{SO}_2(\text{g}) = \text{NO}(\text{g}) + \text{SO}_3(\text{g})$

41652952663.  $2\text{HI}(\text{g}) = \text{H}_2(\text{g}) + \text{I}_2(\text{g})$

41652952664.  $2\text{C}(\text{s}) + \text{O}_2(\text{g}) = 2\text{CO}(\text{g})$

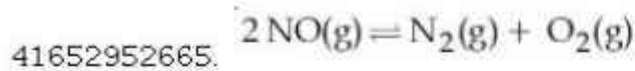

Question Number : 57 Question Id : 41652913472 Question Type : MCQ Option Shuffling : Yes Display Question Number : Yes  
Single Line Question Option : No Option Orientation : Vertical

Correct Marks : 4 Wrong Marks : 1

The molar solubility of  $\text{Cd(OH)}_2$  is  $1.84 \times 10^{-5} \text{ M}$  in water. The expected solubility of  $\text{Cd(OH)}_2$  in a buffer solution of  $\text{pH} = 12$  is :

Options :

41652952666.  $6.23 \times 10^{-11} \text{ M}$

41652952667.  $2.49 \times 10^{-10} \text{ M}$

41652952668.  $\frac{2.49}{1.84} \times 10^{-9} \text{ M}$

41652952669.  $1.84 \times 10^{-9} \text{ M}$

Question Number : 57 Question Id : 41652913472 Question Type : MCQ Option Shuffling : Yes Display Question Number : Yes  
Single Line Question Option : No Option Orientation : Vertical

Correct Marks : 4 Wrong Marks : 1

जल में  $\text{Cd(OH)}_2$  की मोलर विलेयता  $1.84 \times 10^{-5} \text{ M}$  है।  $\text{pH} = 12$  के एक बफर विलयन में  $\text{Cd(OH)}_2$  की सम्भावित विलेयता होगी :

Options :

41652952666.  $6.23 \times 10^{-11} \text{ M}$

41652952667.  $2.49 \times 10^{-10} \text{ M}$

41652952668.  $\frac{2.49}{1.84} \times 10^{-9} \text{ M}$

41652952669.  $1.84 \times 10^{-9} \text{ M}$

Question Number : 58 Question Id : 41652913473 Question Type : MCQ Option Shuffling : Yes Display Question Number : Yes  
Single Line Question Option : No Option Orientation : Vertical

Correct Marks : 4 Wrong Marks : 1

The decreasing order of electrical conductivity of the following aqueous solutions is :

0.1 M Formic acid (A),

0.1 M Acetic acid (B),

0.1 M Benzoic acid (C).

Options :

41652952670.  $A > B > C$

41652952671.  $C > A > B$

41652952672.  $C > B > A$

41652952673.  $A > C > B$

Question Number : 58 Question Id : 41652913473 Question Type : MCQ Option Shuffling : Yes Display Question Number : Yes  
Single Line Question Option : No Option Orientation : Vertical

Correct Marks : 4 Wrong Marks : 1

निम्न जलीय विलयनों की विद्युतीय चालकता का घटता क्रम है,

0.1 M फार्मिक एसिड (A),

0.1 M एसिटिक एसिड (B),

0.1 M बेन्जोइक एसिड (C).

Options :

41652952670.  $A > B > C$

41652952671.  $C > A > B$

41652952672.  $C > B > A$

41652952673.  $A > C > B$

Question Number : 59 Question Id : 41652913474 Question Type : MCQ Option Shuffling : Yes Display Question Number : Yes  
Single Line Question Option : No Option Orientation : Vertical

Correct Marks : 4 Wrong Marks : 1

$\text{NO}_2$  required for a reaction is produced by the decomposition of  $\text{N}_2\text{O}_5$  in  $\text{CCl}_4$  as per the equation,

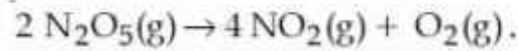

The initial concentration of  $\text{N}_2\text{O}_5$  is  $3.00 \text{ mol L}^{-1}$  and it is  $2.75 \text{ mol L}^{-1}$  after 30 minutes. The rate of formation of  $\text{NO}_2$  is :

Options :

41652952674.  $4.167 \times 10^{-3} \text{ mol L}^{-1} \text{ min}^{-1}$

41652952675.  $8.333 \times 10^{-3} \text{ mol L}^{-1} \text{ min}^{-1}$

41652952676.  $2.083 \times 10^{-3} \text{ mol L}^{-1} \text{ min}^{-1}$

41652952677.  $1.667 \times 10^{-2} \text{ mol L}^{-1} \text{ min}^{-1}$

Question Number : 59 Question Id : 41652913474 Question Type : MCQ Option Shuffling : Yes Display Question Number : Yes  
Single Line Question Option : No Option Orientation : Vertical

Correct Marks : 4 Wrong Marks : 1

एक अभिक्रिया के लिए आवश्यक  $\text{NO}_2$  को  $\text{CCl}_4$  में  $\text{N}_2\text{O}_5$  के अपघटन द्वारा उत्पन्न करते हैं, जैसा कि नीचे समीकरण में है,



$\text{N}_2\text{O}_5$  की प्रारम्भिक सांद्रता  $3.00 \text{ mol L}^{-1}$  तथा 30 मिनट के बाद की सांद्रता  $2.75 \text{ mol L}^{-1}$  है।

$\text{NO}_2$  के सम्भवन की दर होगी :

Options :

41652952674.  $4.167 \times 10^{-3} \text{ mol L}^{-1} \text{ min}^{-1}$

41652952675.  $8.333 \times 10^{-3} \text{ mol L}^{-1} \text{ min}^{-1}$

41652952676.  $2.083 \times 10^{-3} \text{ mol L}^{-1} \text{ min}^{-1}$

41652952677.  $1.667 \times 10^{-2} \text{ mol L}^{-1} \text{ min}^{-1}$

Question Number : 60 Question Id : 41652913475 Question Type : MCQ Option Shuffling : Yes Display Question Number : Yes  
Single Line Question Option : No Option Orientation : Vertical

Correct Marks : 4 Wrong Marks : 1

Among the following, the INCORRECT statement about colloids is :

Options :

The range of diameters of colloidal particles is between 1 and 1000 nm.

41652952678.

They can scatter light.

41652952679.

The osmotic pressure of a colloidal solution is of higher order than the true solution at the same concentration.

41652952680.

They are larger than small molecules and have high molar mass.

41652952681.

Question Number : 60 Question Id : 41652913475 Question Type : MCQ Option Shuffling : Yes Display Question Number : Yes  
Single Line Question Option : No Option Orientation : Vertical

Correct Marks : 4 Wrong Marks : 1

कोलाइड्स के सम्बन्ध में निम्न कथनों में से कौन सा गलत है ?

Options :

कोलाइडी कणों के व्यास का परास 1 तथा 1000 nm के बीच होता है।

41652952678.

ये प्रकाश को प्रकीर्ण कर सकते हैं।

41652952679.

एक ही सांद्रता पर, कोलाइडी विलयन का परासरण दाब, वास्तविक विलयन के दाब की तुलना में उच्चतर मान का होता है।

41652952680.

ये छोटे अणुओं की तुलना में बड़े होते हैं और उनका मोलर द्रव्यमान उच्च होता है।

41652952681.

Mathematics

Section Id :	416529276
Section Number :	3
Section type :	Online
Mandatory or Optional:	Mandatory
Number of Questions:	30
Number of Questions to be attempted:	30
Section Marks:	120
Display Number Panel:	Yes
Group All Questions:	No

Sub-Section Number: 1  
Sub-Section Id: 416529416  
Question Shuffling Allowed : Yes

Question Number : 61 Question Id : 41652913476 Question Type : MCQ Option Shuffling : Yes Display Question Number : Yes  
Single Line Question Option : No Option Orientation : Vertical

Correct Marks : 4 Wrong Marks : 1

Let  $A$ ,  $B$  and  $C$  be sets such that  $\phi \neq A \cap B \subseteq C$ . Then which of the following statements is not true ?

Options :

41652952682.  $B \cap C \neq \phi$

41652952683.  $(C \cup A) \cap (C \cup B) = C$

41652952684. If  $(A - B) \subseteq C$ , then  $A \subseteq C$

41652952685. If  $(A - C) \subseteq B$ , then  $A \subseteq B$

Question Number : 61 Question Id : 41652913476 Question Type : MCQ Option Shuffling : Yes Display Question Number : Yes  
Single Line Question Option : No Option Orientation : Vertical

Correct Marks : 4 Wrong Marks : 1

माना समुच्चय  $A$ ,  $B$  तथा  $C$  इस प्रकार हैं कि  $\phi \neq A \cap B \subseteq C$ , तो निम्न में से कौन सा कथन सत्य नहीं है?

Options :

41652952682.  $B \cap C \neq \phi$

41652952683.  $(C \cup A) \cap (C \cup B) = C$

41652952684. यदि  $(A - B) \subseteq C$ , तो  $A \subseteq C$

41652952685. यदि  $(A - C) \subseteq B$ , तो  $A \subseteq B$

Question Number : 62 Question Id : 41652913477 Question Type : MCQ Option Shuffling : Yes Display Question Number : Yes  
Single Line Question Option : No Option Orientation : Vertical

Correct Marks : 4 Wrong Marks : 1

Let  $z \in \mathbb{C}$  with  $\text{Im}(z) = 10$  and it satisfies

$$\frac{2z - n}{2z + n} = 2i - 1 \text{ for some natural number } n.$$

Then :

Options :

41652952686.  $n = 20$  and  $\text{Re}(z) = 10$

41652952687.  $n = 20$  and  $\text{Re}(z) = -10$

41652952688.  $n = 40$  and  $\text{Re}(z) = 10$

41652952689.  $n = 40$  and  $\text{Re}(z) = -10$

Question Number : 62 Question Id : 41652913477 Question Type : MCQ Option Shuffling : Yes Display Question Number : Yes  
Single Line Question Option : No Option Orientation : Vertical

Correct Marks : 4 Wrong Marks : 1

माना  $z \in \mathbb{C}$  जिसके लिए  $\text{Im}(z) = 10$  तथा किसी प्राकृत

संख्या  $n$  के लिए यह  $\frac{2z - n}{2z + n} = 2i - 1$  को संतुष्ट

करता है, तो :

Options :

41652952686.  $n = 20$  तथा  $\text{Re}(z) = 10$

41652952687.  $n = 20$  तथा  $\text{Re}(z) = -10$

41652952688.  $n = 40$  तथा  $\text{Re}(z) = 10$

41652952689.  $n = 40$  तथा  $\text{Re}(z) = -10$

Question Number : 63 Question Id : 41652913478 Question Type : MCQ Option Shuffling : Yes Display Question Number : Yes  
Single Line Question Option : No Option Orientation : Vertical

Correct Marks : 4 Wrong Marks : 1

If  $\alpha$ ,  $\beta$  and  $\gamma$  are three consecutive terms of a non-constant G.P. such that the equations  $\alpha x^2 + 2\beta x + \gamma = 0$  and  $x^2 + x - 1 = 0$  have a common root, then  $\alpha(\beta + \gamma)$  is equal to :

Options :

41652952690.  $\beta\gamma$

41652952691.  $\alpha\beta$

41652952692.  $\alpha\gamma$

41652952693. 0

Question Number : 63 Question Id : 41652913478 Question Type : MCQ Option Shuffling : Yes Display Question Number : Yes  
Single Line Question Option : No Option Orientation : Vertical

Correct Marks : 4 Wrong Marks : 1

यदि एक भिन्न पदों वाली गुणोत्तर श्रेणी के तीन क्रमागत पद  $\alpha$ ,  $\beta$  तथा  $\gamma$  इस प्रकार हैं कि समीकरणों  $\alpha x^2 + 2\beta x + \gamma = 0$  तथा  $x^2 + x - 1 = 0$  का एक मूल समान है, तो  $\alpha(\beta + \gamma)$  बराबर है :

Options :

41652952690.  $\beta\gamma$

41652952691.  $\alpha\beta$

41652952692.  $\alpha\gamma$

41652952693. 0

Question Number : 64 Question Id : 41652913479 Question Type : MCQ Option Shuffling : Yes Display Question Number : Yes  
Single Line Question Option : No Option Orientation : Vertical

Correct Marks : 4 Wrong Marks : 1

A value of  $\theta \in (0, \pi/3)$ , for which

$$\begin{vmatrix} 1 + \cos^2\theta & \sin^2\theta & 4 \cos 6\theta \\ \cos^2\theta & 1 + \sin^2\theta & 4 \cos 6\theta \\ \cos^2\theta & \sin^2\theta & 1 + 4 \cos 6\theta \end{vmatrix} = 0, \text{ is :}$$

Options :

41652952694.  $\frac{\pi}{18}$

41652952695.  $\frac{\pi}{9}$

41652952696.  $\frac{7\pi}{24}$



41652952697.  $\frac{7\pi}{36}$

Question Number : 64 Question Id : 41652913479 Question Type : MCQ Option Shuffling : Yes Display Question Number : Yes  
Single Line Question Option : No Option Orientation : Vertical

Correct Marks : 4 Wrong Marks : 1

$\theta \in (0, \pi/3)$  का एक मान, जिसके लिए

$$\begin{vmatrix} 1 + \cos^2 \theta & \sin^2 \theta & 4 \cos 6\theta \\ \cos^2 \theta & 1 + \sin^2 \theta & 4 \cos 6\theta \\ \cos^2 \theta & \sin^2 \theta & 1 + 4 \cos 6\theta \end{vmatrix} = 0 \text{ है, है:}$$

Options :

41652952694.  $\frac{\pi}{18}$

41652952695.  $\frac{\pi}{9}$

41652952696.  $\frac{7\pi}{24}$

41652952697.  $\frac{7\pi}{36}$

Question Number : 65 Question Id : 41652913480 Question Type : MCQ Option Shuffling : Yes Display Question Number : Yes  
Single Line Question Option : No Option Orientation : Vertical

Correct Marks : 4 Wrong Marks : 1

If  $[x]$  denotes the greatest integer  $\leq x$ , then

the system of linear equations

$$[\sin \theta]x + [-\cos \theta]y = 0$$

$$[\cot \theta]x + y = 0$$

Options :

has a unique solution if

$$\theta \in \left(\frac{\pi}{2}, \frac{2\pi}{3}\right) \cup \left(\pi, \frac{7\pi}{6}\right).$$

41652952698.

have infinitely many solutions if

$$\theta \in \left(\frac{\pi}{2}, \frac{2\pi}{3}\right) \cup \left(\pi, \frac{7\pi}{6}\right).$$

41652952699.

has a unique solution if  $\theta \in \left(\frac{\pi}{2}, \frac{2\pi}{3}\right)$

and have infinitely many solutions if

$$\theta \in \left(\pi, \frac{7\pi}{6}\right).$$

41652952700.

have infinitely many solutions if

$$\theta \in \left(\frac{\pi}{2}, \frac{2\pi}{3}\right) \text{ and has a unique}$$

$$\text{solution if } \theta \in \left(\pi, \frac{7\pi}{6}\right).$$

41652952701.

Question Number : 65 Question Id : 41652913480 Question Type : MCQ Option Shuffling : Yes Display Question Number : Yes  
Single Line Question Option : No Option Orientation : Vertical

Correct Marks : 4 Wrong Marks : 1

यदि  $[x]$  महत्तम पूर्णांक  $\leq x$  है, तो रेखिक समीकरण

निकाय

$$[\sin\theta]x + [-\cos\theta]y = 0$$

$$[\cot\theta]x + y = 0$$

Options :

का मात्र एक हल है यदि

$$\theta \in \left(\frac{\pi}{2}, \frac{2\pi}{3}\right) \cup \left(\pi, \frac{7\pi}{6}\right).$$

41652952698.

के अनन्त हल हैं यदि

$$\theta \in \left(\frac{\pi}{2}, \frac{2\pi}{3}\right) \cup \left(\pi, \frac{7\pi}{6}\right).$$

41652952699.

का मात्र एक हल है यदि  $\theta \in \left(\frac{\pi}{2}, \frac{2\pi}{3}\right)$  तथा

$$\text{अनन्त हल हैं यदि } \theta \in \left(\pi, \frac{7\pi}{6}\right).$$

41652952700.

के अनन्त हल हैं यदि  $\theta \in \left(\frac{\pi}{2}, \frac{2\pi}{3}\right)$  तथा मात्र

$$\text{एक हल है यदि } \theta \in \left(\pi, \frac{7\pi}{6}\right).$$

41652952701.

Question Number : 66 Question Id : 41652913481 Question Type : MCQ Option Shuffling : Yes Display Question Number : Yes  
Single Line Question Option : No Option Orientation : Vertical

Correct Marks : 4 Wrong Marks : 1

A group of students comprises of 5 boys and  $n$  girls. If the number of ways, in which a team of 3 students can randomly be selected from this group such that there is at least one boy and at least one girl in each team, is 1750, then  $n$  is equal to :

Options :

41652952702. 24

41652952703. 25

41652952704. 27

41652952705. 28

Question Number : 66 Question Id : 41652913481 Question Type : MCQ Option Shuffling : Yes Display Question Number : Yes  
Single Line Question Option : No Option Orientation : Vertical

Correct Marks : 4 Wrong Marks : 1

विद्यार्थियों के एक समूह में 5 लड़के तथा  $n$  लड़कियाँ हैं। यदि इस समूह में से तीन विद्यार्थियों की टीम यादृच्छिक इस प्रकार चुनने के तरीके, कि प्रत्येक टीम में कम से कम एक लड़का तथा कम से कम एक लड़की हो, 1750 हैं, तो  $n$  बराबर है :

Options :

41652952702. 24

41652952703. 25

41652952704. 27

41652952705. 28

Question Number : 67 Question Id : 41652913482 Question Type : MCQ Option Shuffling : Yes Display Question Number : Yes  
Single Line Question Option : No Option Orientation : Vertical

Correct Marks : 4 Wrong Marks : 1

The term independent of  $x$  in the expansion

of  $\left(\frac{1}{60} - \frac{x^8}{81}\right) \cdot \left(2x^2 - \frac{3}{x^2}\right)^6$  is equal to :

Options :

41652952706. -108

41652952707. -72

41652952708. -36

41652952709. 36

Question Number : 67 Question Id : 41652913482 Question Type : MCQ Option Shuffling : Yes Display Question Number : Yes  
Single Line Question Option : No Option Orientation : Vertical

Correct Marks : 4 Wrong Marks : 1

$$\left(\frac{1}{60} - \frac{x^8}{81}\right) \cdot \left(2x^2 - \frac{3}{x^2}\right)^6 \text{ के प्रसार में } x \text{ से}$$

स्वतंत्र पद है :

Options :

41652952706. -108

41652952707. -72

41652952708. -36

41652952709. 36

Question Number : 68 Question Id : 41652913483 Question Type : MCQ Option Shuffling : Yes Display Question Number : Yes  
Single Line Question Option : No Option Orientation : Vertical

Correct Marks : 4 Wrong Marks : 1

If  $a_1, a_2, a_3, \dots$  are in A.P. such that  
 $a_1 + a_7 + a_{16} = 40$ , then the sum of the first  
15 terms of this A.P. is :

Options :

41652952710. 150

41652952711. 120

41652952712. 280

41652952713. 200

Question Number : 68 Question Id : 41652913483 Question Type : MCQ Option Shuffling : Yes Display Question Number : Yes  
Single Line Question Option : No Option Orientation : Vertical

Correct Marks : 4 Wrong Marks : 1

यदि  $a_1, a_2, a_3, \dots$  एक समान्तर श्रेणी में इस प्रकार हैं कि  $a_1 + a_7 + a_{16} = 40$  है, तो इस समान्तर श्रेणी के प्रथम 15 पदों का योगफल है :

Options :

41652952710. 150

41652952711. 120

41652952712. 280

41652952713. 200

Question Number : 69 Question Id : 41652913484 Question Type : MCQ Option Shuffling : Yes Display Question Number : Yes Single Line Question Option : No Option Orientation : Vertical

Correct Marks : 4 Wrong Marks : 1

If  ${}^{20}C_1 + (2^2) {}^{20}C_2 + (3^2) {}^{20}C_3 + \dots + (20^2) {}^{20}C_{20} = A(2^\beta)$ , then the ordered pair  $(A, \beta)$  is equal to :

Options :

41652952714. (380, 18)

41652952715. (380, 19)

41652952716. (420, 18)

41652952717. (420, 19)

Question Number : 69 Question Id : 41652913484 Question Type : MCQ Option Shuffling : Yes Display Question Number : Yes Single Line Question Option : No Option Orientation : Vertical

Correct Marks : 4 Wrong Marks : 1

यदि  ${}^{20}C_1 + (2^2) {}^{20}C_2 + (3^2) {}^{20}C_3 + \dots + (20^2) {}^{20}C_{20} = A(2^\beta)$ , तो क्रमित युग्म  $(A, \beta)$  बराबर है :

Options :

41652952714. (380, 18)

41652952715. (380, 19)

41652952716. (420, 18)

41652952717. (420, 19)

Question Number : 70 Question Id : 41652913485 Question Type : MCQ Option Shuffling : Yes Display Question Number : Yes  
Single Line Question Option : No Option Orientation : Vertical

Correct Marks : 4 Wrong Marks : 1

$$\lim_{x \rightarrow 0} \frac{x + 2\sin x}{\sqrt{x^2 + 2\sin x + 1} - \sqrt{\sin^2 x - x + 1}}$$

is :

Options :

41652952718. 1

41652952719. 2

41652952720. 3

41652952721. 6

Question Number : 70 Question Id : 41652913485 Question Type : MCQ Option Shuffling : Yes Display Question Number : Yes  
Single Line Question Option : No Option Orientation : Vertical

Correct Marks : 4 Wrong Marks : 1

$$\lim_{x \rightarrow 0} \frac{x + 2\sin x}{\sqrt{x^2 + 2\sin x + 1} - \sqrt{\sin^2 x - x + 1}}$$

बराबर है :

Options :

41652952718. 1

41652952719. 2

41652952720. 3

41652952721. 6

Question Number : 71 Question Id : 41652913486 Question Type : MCQ Option Shuffling : Yes Display Question Number : Yes  
Single Line Question Option : No Option Orientation : Vertical

Correct Marks : 4 Wrong Marks : 1

The derivative of  $\tan^{-1}\left(\frac{\sin x - \cos x}{\sin x + \cos x}\right)$ ,

with respect to  $\frac{x}{2}$ , where  $\left(x \in \left(0, \frac{\pi}{2}\right)\right)$  is:

Options :

41652952722.  $\frac{1}{2}$

41652952723.  $\frac{1}{2}$

41652952724.  $\frac{2}{3}$

41652952725.  $\frac{2}{3}$

Question Number : 71 Question Id : 41652913486 Question Type : MCQ Option Shuffling : Yes Display Question Number : Yes  
Single Line Question Option : No Option Orientation : Vertical  
Correct Marks : 4 Wrong Marks : 1

$\frac{x}{2}$  के सापेक्ष  $\tan^{-1}\left(\frac{\sin x - \cos x}{\sin x + \cos x}\right)$ , जहाँ

$\left(x \in \left(0, \frac{\pi}{2}\right)\right)$  का अवकलज है :

Options :

41652952722.  $\frac{1}{2}$

41652952723.  $\frac{1}{2}$

41652952724.  $\frac{2}{3}$

41652952725.  $\frac{2}{3}$

Question Number : 72 Question Id : 41652913487 Question Type : MCQ Option Shuffling : Yes Display Question Number : Yes  
Single Line Question Option : No Option Orientation : Vertical  
Correct Marks : 4 Wrong Marks : 1

The tangents to the curve  $y = (x - 2)^2 - 1$  at its points of intersection with the line  $x - y = 3$ , intersect at the point :

Options :

41652952726.  $\left(\frac{5}{2}, -1\right)$

41652952727.  $\left(-\frac{5}{2}, -1\right)$

41652952728.  $\left(\frac{5}{2}, 1\right)$

41652952729.  $\left(-\frac{5}{2}, 1\right)$

Question Number : 72 Question Id : 41652913487 Question Type : MCQ Option Shuffling : Yes Display Question Number : Yes  
Single Line Question Option : No Option Orientation : Vertical

Correct Marks : 4 Wrong Marks : 1

वक्र  $y = (x - 2)^2 - 1$  के रेखा  $x - y = 3$  से प्रतिच्छेदन बिन्दुओं पर वक्र की स्पर्शिकायें निम्न में से किस बिन्दु पर मिलती हैं?

Options :

41652952726.  $\left(\frac{5}{2}, -1\right)$

41652952727.  $\left(-\frac{5}{2}, -1\right)$

41652952728.  $\left(\frac{5}{2}, 1\right)$

41652952729.  $\left(-\frac{5}{2}, 1\right)$

Question Number : 73 Question Id : 41652913488 Question Type : MCQ Option Shuffling : Yes Display Question Number : Yes  
Single Line Question Option : No Option Orientation : Vertical

Correct Marks : 4 Wrong Marks : 1

Let  $f(x) = 5 - |x - 2|$  and  $g(x) = |x + 1|$ ,  
 $x \in \mathbb{R}$ . If  $f(x)$  attains maximum value at  $\alpha$   
and  $g(x)$  attains minimum value at  $\beta$ , then

$\lim_{x \rightarrow -\alpha\beta} \frac{(x - 1)(x^2 - 5x + 6)}{x^2 - 6x + 8}$  is equal to :

Options :

41652952730.  $1/2$

41652952731.  $-1/2$

41652952732.  $3/2$



41652952733.  $-3/2$

Question Number : 73 Question Id : 41652913488 Question Type : MCQ Option Shuffling : Yes Display Question Number : Yes  
Single Line Question Option : No Option Orientation : Vertical

Correct Marks : 4 Wrong Marks : 1

माना  $f(x) = 5 - |x - 2|$  तथा  $g(x) = |x + 1|$ ,  
 $x \in \mathbb{R}$ . यदि  $f(x)$  का अधिकतम मान  $\alpha$  पर है तथा  $g(x)$   
का न्यूनतम मान  $\beta$  पर है, तो

$\lim_{x \rightarrow -\alpha\beta} \frac{(x-1)(x^2 - 5x + 6)}{x^2 - 6x + 8}$  बराबर है :

Options :

41652952730.  $1/2$

41652952731.  $-1/2$

41652952732.  $3/2$

41652952733.  $-3/2$

Question Number : 74 Question Id : 41652913489 Question Type : MCQ Option Shuffling : Yes Display Question Number : Yes  
Single Line Question Option : No Option Orientation : Vertical

Correct Marks : 4 Wrong Marks : 1

Let  $\alpha \in (0, \pi/2)$  be fixed. If the integral

$$\int \frac{\tan x + \tan \alpha}{\tan x - \tan \alpha} dx =$$

$A(x) \cos 2\alpha + B(x) \sin 2\alpha + C$ , where  $C$  is a  
constant of integration, then the functions  
 $A(x)$  and  $B(x)$  are respectively :

Options :

41652952734.  $x - \alpha$  and  $\log_e |\sin(x - \alpha)|$

41652952735.  $x + \alpha$  and  $\log_e |\sin(x - \alpha)|$

41652952736.  $x - \alpha$  and  $\log_e |\cos(x - \alpha)|$

41652952737.  $x + \alpha$  and  $\log_e |\sin(x + \alpha)|$

Question Number : 74 Question Id : 41652913489 Question Type : MCQ Option Shuffling : Yes Display Question Number : Yes  
Single Line Question Option : No Option Orientation : Vertical

Correct Marks : 4 Wrong Marks : 1

माना  $\alpha \in (0, \pi/2)$  दिया है। यदि समाकल

$$\int \frac{\tan x + \tan \alpha}{\tan x - \tan \alpha} dx =$$

$A(x) \cos 2\alpha + B(x) \sin 2\alpha + C$ , जहाँ  $C$  एक समाकलन अचर है, तो फलन  $A(x)$  तथा  $B(x)$  क्रमशः हैं :

Options :

41652952734.  $x - \alpha$  और  $\log_e |\sin(x - \alpha)|$

41652952735.  $x + \alpha$  और  $\log_e |\sin(x - \alpha)|$

41652952736.  $x - \alpha$  और  $\log_e |\cos(x - \alpha)|$

41652952737.  $x + \alpha$  और  $\log_e |\sin(x + \alpha)|$

Question Number : 75 Question Id : 41652913490 Question Type : MCQ Option Shuffling : Yes Display Question Number : Yes Single Line Question Option : No Option Orientation : Vertical

Correct Marks : 4 Wrong Marks : 1

A value of  $\alpha$  such that

$$\int_{\alpha}^{\alpha+1} \frac{dx}{(x+\alpha)(x+\alpha+1)} = \log_e \left( \frac{9}{8} \right) \text{ is :}$$

Options :

41652952738.  $\frac{1}{2}$

41652952739. 2

41652952740. -2

41652952741.  $-\frac{1}{2}$

Question Number : 75 Question Id : 41652913490 Question Type : MCQ Option Shuffling : Yes Display Question Number : Yes Single Line Question Option : No Option Orientation : Vertical

Correct Marks : 4 Wrong Marks : 1

$\alpha$  का एक मान, जिसके लिए

$$\int_{\alpha}^{\alpha+1} \frac{dx}{(x+\alpha)(x+\alpha+1)} = \log_e \left( \frac{9}{8} \right) \text{ है, है :}$$

Options :

41652952738.  $\frac{1}{2}$

41652952739. 2

41652952740. -2

41652952741.  $-\frac{1}{2}$

Question Number : 76 Question Id : 41652913491 Question Type : MCQ Option Shuffling : Yes Display Question Number : Yes  
Single Line Question Option : No Option Orientation : Vertical

Correct Marks : 4 Wrong Marks : 1

If the area (in sq. units) bounded by the parabola  $y^2 = 4\lambda x$  and the line  $y = \lambda x$ ,

$\lambda > 0$ , is  $\frac{1}{9}$ , then  $\lambda$  is equal to :

Options :

41652952742.  $4\sqrt{3}$

41652952743.  $2\sqrt{6}$

41652952744. 24

41652952745. 48

Question Number : 76 Question Id : 41652913491 Question Type : MCQ Option Shuffling : Yes Display Question Number : Yes  
Single Line Question Option : No Option Orientation : Vertical

Correct Marks : 4 Wrong Marks : 1

यदि परवलय  $y^2 = 4\lambda x$  तथा रेखा  $y = \lambda x$ ,

$\lambda > 0$ , से घिरे क्षेत्र का क्षेत्रफल (वर्ग इकाइयों में)  $\frac{1}{9}$

है, तो  $\lambda$  बराबर है :

Options :

41652952742.  $4\sqrt{3}$

41652952743.  $2\sqrt{6}$

41652952744. 24

41652952745.

Question Number : 77 Question Id : 41652913492 Question Type : MCQ Option Shuffling : Yes Display Question Number : Yes  
Single Line Question Option : No Option Orientation : Vertical

Correct Marks : 4 Wrong Marks : 1

The general solution of the differential equation  $(y^2 - x^3) dx - xydy = 0$  ( $x \neq 0$ ) is :

(where  $c$  is a constant of integration)

Options :

41652952746.  $y^2 + 2x^2 + cx^3 = 0$

41652952747.  $y^2 - 2x^3 + cx^2 = 0$

41652952748.  $y^2 + 2x^3 + cx^2 = 0$

41652952749.  $y^2 - 2x^2 + cx^3 = 0$

Question Number : 77 Question Id : 41652913492 Question Type : MCQ Option Shuffling : Yes Display Question Number : Yes  
Single Line Question Option : No Option Orientation : Vertical

Correct Marks : 4 Wrong Marks : 1

अवकल समीकरण  $(y^2 - x^3) dx - xydy = 0$  ( $x \neq 0$ ) का व्यापक हल है :

(जहाँ  $c$  एक समाकलन अचर है)

Options :

41652952746.  $y^2 + 2x^2 + cx^3 = 0$

41652952747.  $y^2 - 2x^3 + cx^2 = 0$

41652952748.  $y^2 + 2x^3 + cx^2 = 0$

41652952749.  $y^2 - 2x^2 + cx^3 = 0$

Question Number : 78 Question Id : 41652913493 Question Type : MCQ Option Shuffling : Yes Display Question Number : Yes  
Single Line Question Option : No Option Orientation : Vertical

Correct Marks : 4 Wrong Marks : 1

A straight line  $L$  at a distance of 4 units from the origin makes positive intercepts on the coordinate axes and the perpendicular from the origin to this line makes an angle of  $60^\circ$  with the line  $x + y = 0$ . Then an equation of the line  $L$  is :

Options :

41652952750.  $(\sqrt{3} + 1)x + (\sqrt{3} - 1)y = 8\sqrt{2}$

41652952751.  $(\sqrt{3} - 1)x + (\sqrt{3} + 1)y = 8\sqrt{2}$

41652952752.  $\sqrt{3}x + y = 8$

41652952753.  $x + \sqrt{3}y = 8$

Question Number : 78 Question Id : 41652913493 Question Type : MCQ Option Shuffling : Yes Display Question Number : Yes  
Single Line Question Option : No Option Orientation : Vertical

Correct Marks : 4 Wrong Marks : 1

मूलबिन्दु से 4 इकाई की दूरी पर एक सरल रेखा L निर्देशांक अक्षों पर धनात्मक अंतःखण्ड बनाती है तथा मूलबिन्दु से इस रेखा पर लंब, रेखा  $x + y = 0$  के साथ  $60^\circ$  का कोण बनाता है। तो रेखा L का एक समीकरण है :

Options :

41652952750.  $(\sqrt{3} + 1)x + (\sqrt{3} - 1)y = 8\sqrt{2}$

41652952751.  $(\sqrt{3} - 1)x + (\sqrt{3} + 1)y = 8\sqrt{2}$

41652952752.  $\sqrt{3}x + y = 8$

41652952753.  $x + \sqrt{3}y = 8$

Question Number : 79 Question Id : 41652913494 Question Type : MCQ Option Shuffling : Yes Display Question Number : Yes  
Single Line Question Option : No Option Orientation : Vertical

Correct Marks : 4 Wrong Marks : 1

A triangle has a vertex at (1, 2) and the mid points of the two sides through it are (-1, 1) and (2, 3). Then the centroid of this triangle is :

Options :

41652952754.  $\left(\frac{1}{3}, 1\right)$

41652952755.  $\left(\frac{1}{3}, 2\right)$

41652952756.  $\left(1, \frac{7}{3}\right)$

41652952757.  $\left(\frac{1}{3}, \frac{5}{3}\right)$

Question Number : 79 Question Id : 41652913494 Question Type : MCQ Option Shuffling : Yes Display Question Number : Yes  
Single Line Question Option : No Option Orientation : Vertical

Correct Marks : 4 Wrong Marks : 1

एक त्रिभुज का एक शीर्ष  $(1, 2)$  पर है तथा इससे होकर जाने वाली दो भुजाओं के मध्य-बिन्दु  $(-1, 1)$  और  $(2, 3)$  हैं। तो इस त्रिभुज का केन्द्रक है :

Options :

41652952754.  $\left(\frac{1}{3}, 1\right)$

41652952755.  $\left(\frac{1}{3}, 2\right)$

41652952756.  $\left(1, \frac{7}{3}\right)$

41652952757.  $\left(\frac{1}{3}, \frac{5}{3}\right)$

Question Number : 80 Question Id : 41652913495 Question Type : MCQ Option Shuffling : Yes Display Question Number : Yes  
Single Line Question Option : No Option Orientation : Vertical

Correct Marks : 4 Wrong Marks : 1

A circle touching the  $x$ -axis at  $(3, 0)$  and making an intercept of length 8 on the  $y$ -axis passes through the point :

Options :

41652952758.  $(3, 10)$

41652952759.  $(3, 5)$

41652952760.  $(1, 5)$

41652952761.  $(2, 3)$

Question Number : 80 Question Id : 41652913495 Question Type : MCQ Option Shuffling : Yes Display Question Number : Yes  
Single Line Question Option : No Option Orientation : Vertical

Correct Marks : 4 Wrong Marks : 1

$x$ -अक्ष को  $(3, 0)$  पर स्पर्श करता हुआ तथा  $y$ -अक्ष पर 8 लम्बाई का अंतःखण्ड (intercept) बनाता हुआ एक वृत्त निम्न में से किस बिन्दु से होकर जाता है?

Options :

41652952758.  $(3, 10)$

41652952759.  $(3, 5)$

41652952760.  $(1, 5)$

41652952761.  $(2, 3)$

Question Number : 81 Question Id : 41652913496 Question Type : MCQ Option Shuffling : Yes Display Question Number : Yes  
Single Line Question Option : No Option Orientation : Vertical

Correct Marks : 4 Wrong Marks : 1

The equation of a common tangent to the curves,  $y^2 = 16x$  and  $xy = -4$ , is :

Options :

41652952762.  $x - 2y + 16 = 0$

41652952763.  $x + y + 4 = 0$

41652952764.  $2x - y + 2 = 0$

41652952765.  $x - y + 4 = 0$

Question Number : 81 Question Id : 41652913496 Question Type : MCQ Option Shuffling : Yes Display Question Number : Yes  
Single Line Question Option : No Option Orientation : Vertical

Correct Marks : 4 Wrong Marks : 1

वक्रों  $y^2 = 16x$  तथा  $xy = -4$  की एक उभयनिष्ठ स्पर्शरेखा का समीकरण है :

Options :

41652952762.  $x - 2y + 16 = 0$

41652952763.  $x + y + 4 = 0$

41652952764.  $2x - y + 2 = 0$

41652952765.  $x - y + 4 = 0$

Question Number : 82 Question Id : 41652913497 Question Type : MCQ Option Shuffling : Yes Display Question Number : Yes  
Single Line Question Option : No Option Orientation : Vertical

Correct Marks : 4 Wrong Marks : 1

An ellipse, with foci at  $(0, 2)$  and  $(0, -2)$   
and minor axis of length 4, passes through  
which of the following points ?

Options :

41652952766.  $(2, \sqrt{2})$

41652952767.  $(1, 2\sqrt{2})$

41652952768.  $(\sqrt{2}, 2)$

41652952769.  $(2, 2\sqrt{2})$

Question Number : 82 Question Id : 41652913497 Question Type : MCQ Option Shuffling : Yes Display Question Number : Yes  
Single Line Question Option : No Option Orientation : Vertical

Correct Marks : 4 Wrong Marks : 1

एक दीर्घवृत्त, जिसकी नाभियाँ  $(0, 2)$  तथा  $(0, -2)$  पर  
हैं तथा जिसके लघु अक्ष की लम्बाई 4 है, निम्न में से  
किस बिन्दु से होकर जाता है ?

Options :

41652952766.  $(2, \sqrt{2})$

41652952767.  $(1, 2\sqrt{2})$

41652952768.  $(\sqrt{2}, 2)$

41652952769.  $(2, 2\sqrt{2})$

Question Number : 83 Question Id : 41652913498 Question Type : MCQ Option Shuffling : Yes Display Question Number : Yes  
Single Line Question Option : No Option Orientation : Vertical

Correct Marks : 4 Wrong Marks : 1



A plane which bisects the angle between the two given planes  $2x - y + 2z - 4 = 0$  and  $x + 2y + 2z - 2 = 0$ , passes through the point :

Options :

41652952770. (1, -4, 1)

41652952771. (2, 4, 1)

41652952772. (2, -4, 1)

41652952773. (1, 4, -1)

Question Number : 83 Question Id : 41652913498 Question Type : MCQ Option Shuffling : Yes Display Question Number : Yes  
Single Line Question Option : No Option Orientation : Vertical

Correct Marks : 4 Wrong Marks : 1

दो दिए गए समतलों  $2x - y + 2z - 4 = 0$  तथा  $x + 2y + 2z - 2 = 0$  के बीच के कोण को समद्विभाजित करता एक समतल, निम्न में से किस बिन्दु से होकर जाता है ?

Options :

41652952770. (1, -4, 1)

41652952771. (2, 4, 1)

41652952772. (2, -4, 1)

41652952773. (1, 4, -1)

Question Number : 84 Question Id : 41652913499 Question Type : MCQ Option Shuffling : Yes Display Question Number : Yes  
Single Line Question Option : No Option Orientation : Vertical

Correct Marks : 4 Wrong Marks : 1

The length of the perpendicular drawn from the point (2, 1, 4) to the plane containing the lines

$$\vec{r} = (\hat{i} + \hat{j}) + \lambda(\hat{i} + 2\hat{j} - \hat{k}) \quad \text{and}$$

$$\vec{r} = (\hat{i} + \hat{j}) + \mu(-\hat{i} + \hat{j} - 2\hat{k}) \text{ is :}$$

Options :

41652952774. 3

41652952775.  $\sqrt{3}$

41652952776.  $\frac{1}{3}$

41652952777.  $\frac{1}{\sqrt{3}}$

Question Number : 84 Question Id : 41652913499 Question Type : MCQ Option Shuffling : Yes Display Question Number : Yes  
Single Line Question Option : No Option Orientation : Vertical  
Correct Marks : 4 Wrong Marks : 1

रेखाओं  $\vec{r} = (\hat{i} + \hat{j}) + \lambda(\hat{i} + 2\hat{j} - \hat{k})$  तथा

$\vec{r} = (\hat{i} + \hat{j}) + \mu(-\hat{i} + \hat{j} - 2\hat{k})$  को अंतर्विष्ट

करते समतल पर बिन्दु (2, 1, 4) से डाले गये लम्ब की लम्बाई है :

Options :

41652952774. 3

41652952775.  $\sqrt{3}$

41652952776.  $\frac{1}{3}$

41652952777.  $\frac{1}{\sqrt{3}}$

Question Number : 85 Question Id : 41652913500 Question Type : MCQ Option Shuffling : Yes Display Question Number : Yes  
Single Line Question Option : No Option Orientation : Vertical  
Correct Marks : 4 Wrong Marks : 1

Let  $\alpha \in \mathbb{R}$  and the three vectors

$\vec{a} = \alpha\hat{i} + \hat{j} + 3\hat{k}$ ,  $\vec{b} = 2\hat{i} + \hat{j} - \alpha\hat{k}$

and  $\vec{c} = \alpha\hat{i} - 2\hat{j} + 3\hat{k}$ . Then the set

$S = \{\alpha : \vec{a}, \vec{b} \text{ and } \vec{c} \text{ are coplanar}\}$

Options :

41652952778. is empty

41652952779. is singleton

41652952780. contains exactly two positive numbers

41652952781. contains exactly two numbers only one of which is positive

Question Number : 85 Question Id : 41652913500 Question Type : MCQ Option Shuffling : Yes Display Question Number : Yes Single Line Question Option : No Option Orientation : Vertical

Correct Marks : 4 Wrong Marks : 1

माना  $\alpha \in \mathbb{R}$  तथा तीन सदिश  $\vec{a} = \alpha \hat{i} + \hat{j} + 3\hat{k}$ ,

$\vec{b} = 2\hat{i} + \hat{j} - \alpha\hat{k}$  और

$\vec{c} = \alpha\hat{i} - 2\hat{j} + 3\hat{k}$  हैं। तो समुच्चय

$S = \{\alpha : \vec{a}, \vec{b} \text{ और } \vec{c} \text{ समतलीय हैं}\}$

Options :

41652952778. रिक्त है।

41652952779. एकल है।

41652952780. में तथ्यतः (exactly) दो धनात्मक संख्यायें हैं।

41652952781. में तथ्यतः दो संख्यायें हैं जिनमें से केवल एक धनात्मक है।

Question Number : 86 Question Id : 41652913501 Question Type : MCQ Option Shuffling : Yes Display Question Number : Yes Single Line Question Option : No Option Orientation : Vertical

Correct Marks : 4 Wrong Marks : 1

A person throws two fair dice. He wins Rs. 15 for throwing a doublet (same numbers on the two dice), wins Rs. 12 when the throw results in the sum of 9, and loses Rs. 6 for any other outcome on the throw. Then the expected gain/loss (in Rs.) of the person is :

Options :

41652952782. 2 gain

41652952783.  $\frac{1}{2}$  loss

41652952784.  $\frac{1}{2}$  gain

41652952785.  $\frac{1}{4}$  loss

Question Number : 86 Question Id : 41652913501 Question Type : MCQ Option Shuffling : Yes Display Question Number : Yes  
Single Line Question Option : No Option Orientation : Vertical

Correct Marks : 4 Wrong Marks : 1

एक व्यक्ति दो न्याय्य (fair) पासे उछालता है। एक द्विक (दोनों पासों पर एक ही संख्या) आने पर वह रु. 15 जीतता है, दोनों पासों पर आए अंकों का योग 9 होने पर रु. 12 जीतता है तथा किसी अन्य परिणाम (outcome) पर रु. 6 हारता है। तो उस व्यक्ति का प्रत्याशित (expected) लाभ/हानि (रु.में) है :

Options :

41652952782. लाभ 2

41652952783. हानि  $\frac{1}{2}$

41652952784. लाभ  $\frac{1}{2}$

41652952785. हानि  $\frac{1}{4}$

Question Number : 87 Question Id : 41652913502 Question Type : MCQ Option Shuffling : Yes Display Question Number : Yes  
Single Line Question Option : No Option Orientation : Vertical

Correct Marks : 4 Wrong Marks : 1

For an initial screening of an admission test, a candidate is given fifty problems to solve. If the probability that the candidate can solve any problem is  $\frac{4}{5}$ , then the probability that he is unable to solve less than two problems is :

Options :

41652952786.  $\frac{201}{5} \left(\frac{1}{5}\right)^{49}$

41652952787.  $\frac{54}{5} \left(\frac{4}{5}\right)^{49}$

41652952788.  $\frac{316}{25} \left(\frac{4}{5}\right)^{48}$

41652952789.  $\frac{164}{25} \left(\frac{1}{5}\right)^{48}$

Question Number : 87 Question Id : 41652913502 Question Type : MCQ Option Shuffling : Yes Display Question Number : Yes  
Single Line Question Option : No Option Orientation : Vertical

Correct Marks : 4 Wrong Marks : 1

प्रारंभिक जाँच के लिए एक प्रवेश परीक्षा में एक परीक्षार्थी को पचास प्रश्न हल करने के लिए दिए गए हैं। यदि परीक्षार्थी के किसी एक प्रश्न को हल कर सकने की प्रायिकता  $\frac{4}{5}$  है, तो उसके दो से कम प्रश्नों को हल

करने में असमर्थ होने की प्रायिकता है :

Options :

41652952786.  $\frac{201}{5} \left(\frac{1}{5}\right)^{49}$

41652952787.  $\frac{54}{5} \left(\frac{4}{5}\right)^{49}$

41652952788.  $\frac{316}{25} \left(\frac{4}{5}\right)^{48}$

41652952789.  $\frac{164}{25} \left(\frac{1}{5}\right)^{48}$

Question Number : 88 Question Id : 41652913503 Question Type : MCQ Option Shuffling : Yes Display Question Number : Yes  
Single Line Question Option : No Option Orientation : Vertical

Correct Marks : 4 Wrong Marks : 1

Let S be the set of all  $\alpha \in \mathbb{R}$  such that the equation,  $\cos 2x + \alpha \sin x = 2\alpha - 7$  has a solution. Then S is equal to :

Options :

41652952790. R

41652952791. [2, 6]

41652952792. [1, 4]

41652952793. [3, 7]

Question Number : 88 Question Id : 41652913503 Question Type : MCQ Option Shuffling : Yes Display Question Number : Yes  
Single Line Question Option : No Option Orientation : Vertical  
Correct Marks : 4 Wrong Marks : 1

माना सभी  $\alpha \in \mathbb{R}$ , जिसके लिए समीकरण  
 $\cos 2x + \alpha \sin x = 2\alpha - 7$  का एक हल है, का समुच्चय  
S है। तो S बराबर है :

Options :

41652952790. R

41652952791. [2, 6]

41652952792. [1, 4]

41652952793. [3, 7]

Question Number : 89 Question Id : 41652913504 Question Type : MCQ Option Shuffling : Yes Display Question Number : Yes  
Single Line Question Option : No Option Orientation : Vertical  
Correct Marks : 4 Wrong Marks : 1

The angle of elevation of the top of a vertical tower standing on a horizontal plane is observed to be  $45^\circ$  from a point A on the plane. Let B be the point 30 m vertically above the point A. If the angle of elevation of the top of the tower from B be  $30^\circ$ , then the distance (in m) of the foot of the tower from the point A is :

Options :

41652952794.  $15(3 - \sqrt{3})$

41652952795.  $15(3 + \sqrt{3})$

41652952796.  $15(1 + \sqrt{3})$

41652952797.  $15(5 - \sqrt{3})$

Question Number : 89 Question Id : 41652913504 Question Type : MCQ Option Shuffling : Yes Display Question Number : Yes  
Single Line Question Option : No Option Orientation : Vertical

Correct Marks : 4 Wrong Marks : 1

क्षैतिज तल पर खड़ी एक उर्ध्वाधर मीनार के शिखर का तल पर एक बिन्दु A से उन्नयन कोण  $45^\circ$  है। माना बिन्दु A से 30 मीटर उर्ध्वाधर ऊपर बिन्दु B है। यदि B से मीनार के शिखर का उन्नयन कोण  $30^\circ$  है, तो मीनार के पाद की बिन्दु A से दूरी (मीटर में) है :

Options :

41652952794.  $15(3 - \sqrt{3})$

41652952795.  $15(3 + \sqrt{3})$

41652952796.  $15(1 + \sqrt{3})$

41652952797.  $15(5 - \sqrt{3})$

Question Number : 90 Question Id : 41652913505 Question Type : MCQ Option Shuffling : Yes Display Question Number : Yes  
Single Line Question Option : No Option Orientation : Vertical

Correct Marks : 4 Wrong Marks : 1

The Boolean expression  $\sim(p \Rightarrow (\sim q))$  is equivalent to :

Options :

41652952798.  $(\sim p) \Rightarrow q$

41652952799.  $q \Rightarrow \sim p$

41652952800.  $p \wedge q$

41652952801.  $p \vee q$

Question Number : 90 Question Id : 41652913505 Question Type : MCQ Option Shuffling : Yes Display Question Number : Yes  
Single Line Question Option : No Option Orientation : Vertical

Correct Marks : 4 Wrong Marks : 1

बूले का व्यंजक  $\sim(p \Rightarrow (\sim q))$  निम्न में से किसके समतुल्य है?

Options :

41652952798.  $(\sim p) \Rightarrow q$

41652952799.  $q \Rightarrow \sim p$

41652952800.  $p \wedge q$

41652952801.  $p \vee q$