

CURRENT ELECTRICITY

1. The figure shows a circuit having eight resistances of $1\ \Omega$ each, labelled R_1 to R_8 , and two ideal batteries with voltages $\varepsilon_1 = 12\ V$ and $\varepsilon_2 = 6\ V$.
[JEE(Advanced) 2022]

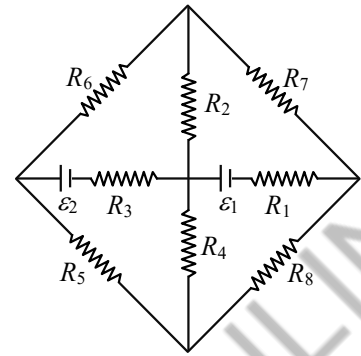

Which of the following statement(s) is(are) correct?

- (A) The magnitude of current flowing through R_1 is $7.2\ A$.
 (B) The magnitude of current flowing through R_2 is $1.2\ A$.
 (C) The magnitude of current flowing through R_3 is $4.8\ A$.
 (D) The magnitude of current flowing through R_5 is $2.4\ A$.
2. Two resistances $R_1 = X\ \Omega$ and $R_2 = 1\ \Omega$ are connected to a wire AB of uniform resistivity, as shown in the figure. The radius of the wire varies linearly along its axis from $0.2\ \text{mm}$ at A to $1\ \text{mm}$ at B. A galvanometer (G) connected to the center of the wire, $50\ \text{cm}$ from each end along its axis, shows zero deflection when A and B are connected to a battery. The value of X is _____. [JEE(Advanced) 2022]

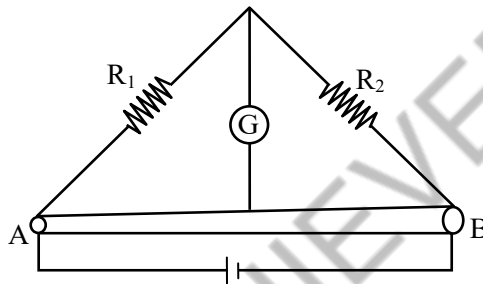

3. In Circuit-1 and Circuit-2 shown in the figures, $R_1 = 1\ \Omega$, $R_2 = 2\ \Omega$ and $R_3 = 3\ \Omega$. P_1 and P_2 are the power dissipations in Circuit-1 and Circuit-2 when the switches S_1 and S_2 are in open conditions, respectively. Q_1 and Q_2 are the power dissipations in Circuit-1 and Circuit-2 when the switches S_1 and S_2 are in closed conditions, respectively.
[JEE(Advanced) 2022]

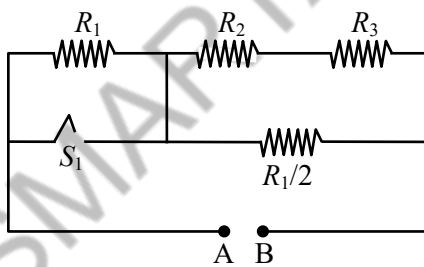

Circuit-1

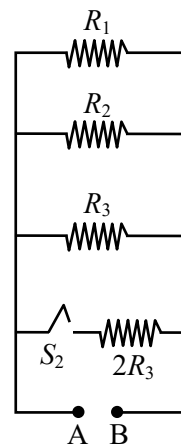

Circuit-2

Which of the following statement(s) is(are) correct?

- (A) When a voltage source of $6\ V$ is connected across A and B in both circuits, $P_1 < P_2$.
 (B) When a constant current source of $2\ \text{Amp}$ is connected across A and B in both circuits, $P_1 > P_2$.
 (C) When a voltage source of $6\ V$ is connected across A and B in Circuit-1, $Q_1 > P_1$.
 (D) When a constant current source of $2\ \text{Amp}$ is connected across A and B in both circuits, $Q_2 < Q_1$.

4. In order to measure the internal resistance r_1 of a cell of emf E , a meter bridge of wire resistance $R_0 = 50 \Omega$, a resistance $R_0/2$, another cell of emf $E/2$ (internal resistance r) and a galvanometer G are used in a circuit, as shown in the figure. If the null point is found at $l = 72 \text{ cm}$, then the value of $r_1 = \underline{\hspace{2cm}} \Omega$.
[JEE(Advanced) 2021]

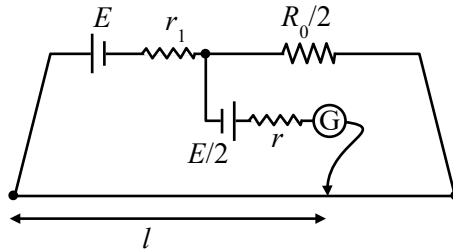

5. Shown in the figure is a semicircular metallic strip that has thickness t and resistivity ρ . Its inner radius is R_1 and outer radius is R_2 . If a voltage V_0 is applied between its two ends, a current I flows in it. In addition, it is observed that a transverse voltage ΔV develops between its inner and outer surfaces due to purely kinetic effects of moving electrons (ignore any role of the magnetic field due to the current). Then (figure is schematic and not drawn to scale)-
[JEE(Advanced) 2020]

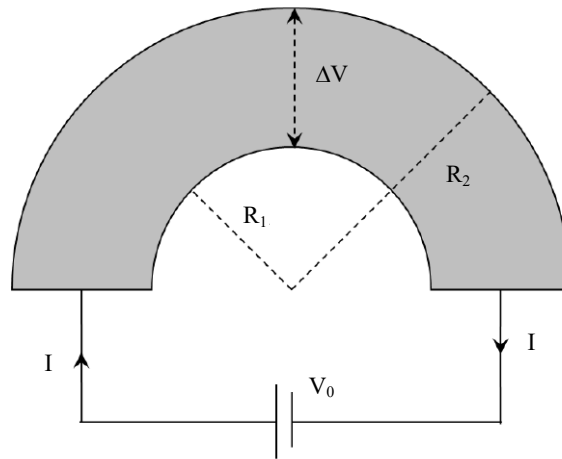

- (A) $I = \frac{V_0 t}{\pi \rho} \ln \left(\frac{R_2}{R_1} \right)$
 (B) the outer surface is at a higher voltage than the inner surface
 (C) the outer surface is at a lower voltage than the inner surface
 (D) $\Delta V \propto I^2$
6. In the balanced condition, the values of the resistances of the four arms of a Wheatstone bridge are shown in the figure below. The resistance R_3 has temperature coefficient $0.0004 \text{ } ^\circ\text{C}^{-1}$. If the temperature of R_3 is increased by 100°C , the voltage developed between S and T will be $\underline{\hspace{2cm}}$ volt. **[JEE(Advanced) 2020]**

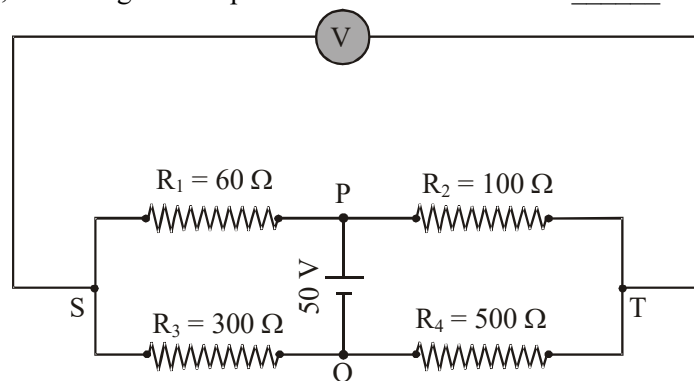

7. Two identical moving coil galvanometer have $10\ \Omega$ resistance and full scale deflection at $2\ \mu\text{A}$ current. One of them is converted into a voltmeter of $100\ \text{mV}$ full scale reading and the other into an Ammeter of $1\ \text{mA}$ full scale current using appropriate resistors. These are then used to measure the voltage and current in the Ohm's law experiment with $R = 1000\ \Omega$ resistor by using an ideal cell. Which of the following statement(s) is/are correct ? [JEE(Advanced) 2019]
- (A) The measured value of R will be $978\ \Omega < R < 982\ \Omega$.
- (B) The resistance of the Voltmeter will be $100\ \text{k}\Omega$.
- (C) The resistance of the Ammeter will be $0.02\ \Omega$ (round off to 2nd decimal place)
- (D) If the ideal cell is replaced by a cell having internal resistance of $5\ \Omega$ then the measured value of R will be more than $1000\ \Omega$.
8. An incandescent bulb has a thin filament of tungsten that is heated to high temperature by passing an electric current. The hot filament emits black-body radiation. The filament is observed to break up at random locations after a sufficiently long time of operation due to non-uniform evaporation of tungsten from the filament. If the bulb is powered at constant voltage, which of the following statement(s) is(are) true? [JEE(Advanced) 2016]
- (A) The temperature distribution over the filament is uniform
- (B) The resistance over small sections of the filament decreases with time
- (C) The filament emits more light at higher band of frequencies before it breaks up
- (D) The filament consumes less electrical power towards the end of the life of the bulb
9. Consider two identical galvanometers and two identical resistors with resistance R . If the internal resistance of the galvanometers $R_C < R/2$, which of the following statement(s) about any one of the galvanometers is(are) true ? [JEE(Advanced) 2016]
- (A) The maximum voltage range is obtained when all the components are connected in series
- (B) The maximum voltage range is obtained when the two resistors and one galvanometer are connected in series, and the second galvanometer is connected in parallel to the first galvanometer
- (C) The maximum current range is obtained when all the components are connected in parallel
- (D) The maximum current range is obtained when the two galvanometers are connected in series and the combination is connected in parallel with both the resistors.

Paragraph for Question No. 10 and 11

Consider an evacuated cylindrical chamber of height h having rigid conducting plates at the ends and an insulating curved surface as shown in the figure. A number of spherical balls made of a light weight and soft material and coated with a conducting material are placed on the bottom plate. The balls have a radius $r \ll h$. Now a high voltage source (HV) is connected across the conducting plates such that the bottom plate is at $+V_0$ and the top plate at $-V_0$. Due to their conducting surface, the balls will get charged, will become equipotential with the plate and are repelled by it. The balls will eventually collide with the top plate, where the coefficient of restitution can be taken to be zero due to the soft nature of the material of the balls. The electric field in the chamber can be considered to be that of a parallel plate capacitor. Assume that there are no collision between the balls and the interaction between them is negligible. (Ignore gravity)

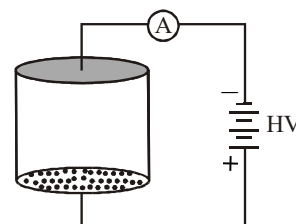

10. Which of the following statements is correct ? [JEE(Advanced) 2016]
 (A) The balls will bounce back to the bottom plate carrying the opposite charge they went up with
 (B) the balls will execute simple harmonic motion between the two plates
 (C) The balls will bounce back to the bottom plate carrying the same charge they went up with
 (D) The balls will stick to the top plate and remain there
11. The average current in the steady state registered by the ammeter in the circuit will be :
 (A) Proportional to $V_0^{1/2}$ (B) Proportional to V_0^2 [JEE(Advanced) 2016]
 (C) Proportional to the potential V_0 (D) Zero
12. In an aluminum (Al) bar of square cross section, a square hole is drilled and is filled with iron (Fe) as shown in the figure. The electrical resistivities of Al and Fe are $2.7 \times 10^{-8} \Omega \text{ m}$ and $1.0 \times 10^{-7} \Omega \text{ m}$, respectively. The electrical resistance between the two faces P and Q of the composite bar is : [JEE(Advanced) 2015]

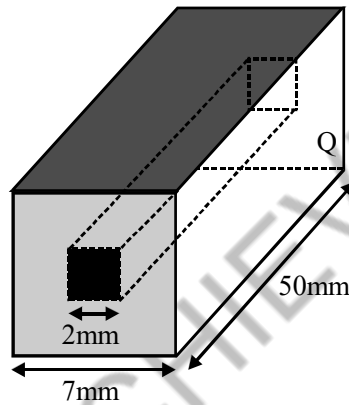

- (A) $\frac{2475}{64} \mu\Omega$ (B) $\frac{1875}{64} \mu\Omega$ (C) $\frac{1875}{49} \mu\Omega$ (D) $\frac{2475}{132} \mu\Omega$

13. In the following circuit, the current through the resistor $R (= 2\Omega)$ is I Amperes. The value of I is [JEE(Advanced) 2015]

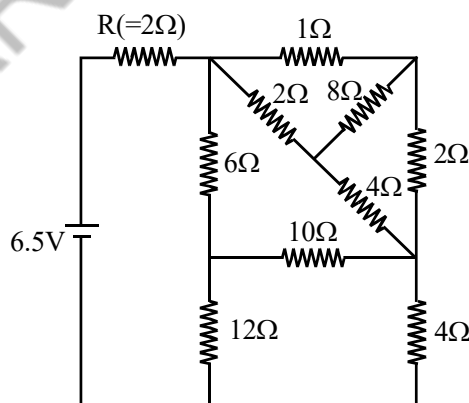

14. Heater of an electric kettle is made of a wire of length L and diameter d . It takes 4 minutes to raise the temperature of 0.5 kg water by 40 K. This heater is replaced by a new heater having two wires of the same material, each of length L and diameter $2d$. The way these wires are connected is given in the options. How much time in minutes will it take to raise the temperature of the same amount of water by 40 K ?
 (A) 4 if wires are in parallel (B) 2 if wires are in series [JEE(Advanced) 2014]
 (C) 1 if wires are in series (D) 0.5 if wires are in parallel

15. Two ideal batteries of emf V_1 and V_2 and three resistances R_1 , R_2 and R_3 are connected as shown in the figure. The current in resistance R_2 would be zero if :- [JEE(Advanced) 2014]

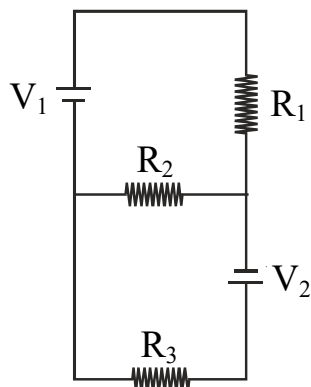

- (A) $V_1 = V_2$ and $R_1 = R_2 = R_3$ (B) $V_1 = V_2$ and $R_1 = 2R_2 = R_3$
 (C) $V_1 = 2V_2$ and $2R_1 = 2R_2 = R_3$ (D) $2V_1 = V_2$ and $2R_1 = R_2 = R_3$
16. A galvanometer gives full scale deflection with 0.006 A current. By connecting it to a 4990Ω resistance, it can be converted into a voltmeter of range 0 - 30 V. If connected to a $\frac{2n}{249} \Omega$ resistance, it becomes an ammeter of range 0 - 1.5 A. The value of n is [JEE(Advanced) 2014]
17. During an experiment with a metre bridge, the galvanometer shows a null point when the jockey is pressed at 40.0 cm using a standard resistance of 90Ω , as shown in the figure. The least count of the scale used in the metre bridge is 1mm. The unknown resistance is :- [JEE(Advanced) 2014]

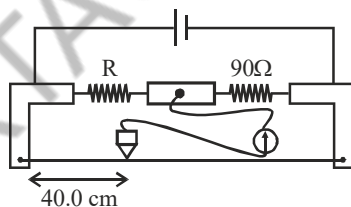

- (A) $60 \pm 0.15 \Omega$ (B) $135 \pm 0.56 \Omega$
 (C) $60 \pm 0.25 \Omega$ (D) $135 \pm 0.23 \Omega$

SOLUTIONS

1. Ans. (A, B, C, D)

Sol.

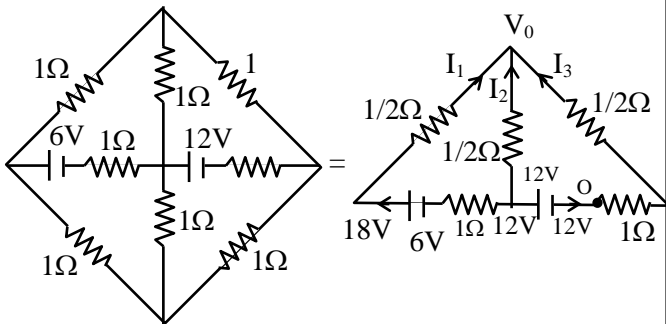

From KCL

$$i_1 + i_2 + i_3 = 0$$

$$\Rightarrow \frac{18 - V_0}{3/2} + \frac{12 - V_0}{1/2} + \frac{0 - V_0}{3/2} = 0$$

$$\Rightarrow 18 - V_0 + 36 - 3V_0 - V_0 = 0$$

$$\Rightarrow 54 = 5V_0$$

$$\frac{2\left(\frac{54}{5} - v'\right)}{1} + \frac{18 - v'}{1} = 0$$

$$\Rightarrow \frac{108}{5} + 18 = 3V' \Rightarrow v' = \frac{198}{5 \times 3} = \frac{66}{5} \text{ V}$$

$$I_{R_1} = \frac{36}{5} = 7.2 \text{ A}$$

$$I_{R_2} = \frac{6}{5} = 1.2 \text{ A}$$

$$I_{R_3} = \frac{24}{5} = 4.8 \text{ A}$$

$$I_{R_5} = \frac{12}{5} = 2.4 \text{ A}$$

2. Ans. (5)

Sol. For the balanced Wheatstone bridge

$$\frac{R_1}{R_2} = \frac{\int_0^{0.5} \frac{\rho dx}{\pi r_x^2}}{\int_{0.5}^1 \frac{\rho dx}{\pi r_x^2}}$$

$$\frac{R_1}{R_2} = \frac{\left[\frac{1}{r_x} \right]_0^{0.5}}{\left[\frac{1}{r_x} \right]_{0.5}^1}$$

$$\therefore R_1 = 5R_2 = 5\Omega$$

3. Ans. (A, B, C)

Sol. Case (i)

When both switches are open equivalent resistance in circuit 1

$$R_{C_1} = \frac{16}{11} \Omega$$

Equivalent resistance in circuit 2

$$R_{C_2} = \frac{6}{11} \Omega$$

For voltage source

$$P = \frac{V^2}{R}$$

$$P \propto \frac{1}{R}$$

$$R_{C_1} > R_{C_2}$$

$$\Rightarrow P_2 > P_1 \text{ (Option (A) correct)}$$

For constant current source

$$P = i^2 R$$

$$P \propto R$$

$$\Rightarrow P_1 > P_2 \text{ (Option (B) correct)}$$

Case-II

When switch is closed

$$R'_{C_1} = \frac{5}{11} \Omega$$

$$R'_{C_2} = \frac{1}{2} \Omega$$

$$R'_{C_1} < R_{C_1}$$

For voltage source

$$P \propto \frac{1}{R} \Rightarrow Q_1 > P_1 \text{ (Option (C) correct)}$$

$$\& R'_{C_1} > R'_{C_2}$$

For current source $P \propto R$

$$Q_1 > Q_2 \text{ (Option (D) also correct)}$$

4. Ans. (3)

Sol.

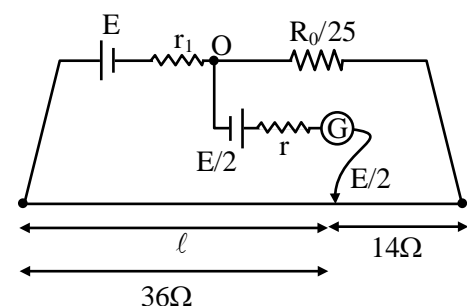

$$i \left(\frac{R_0}{2} + 0.28R_0 \right) = \frac{E_0}{2}$$

$$i \times 0.78R_0 = \frac{E_0}{2}$$

$$i = \frac{E_0}{2 \times 0.78R_0} = \frac{E_0}{r_1 + \frac{3}{2}R_0}$$

$$r_1 + 1.5 R_0 = 1.56 R_0$$

$$r_1 = 0.06 R_0 = 0.06 \times 50 = 3 \Omega$$

5. **Ans. (A, C, D)**

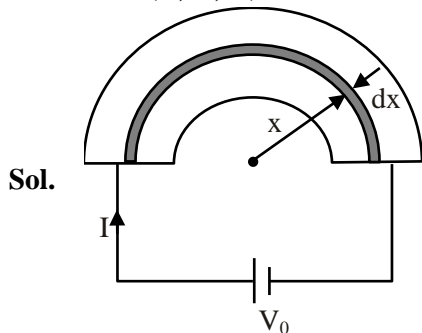

All the elements are in parallel

$$\therefore \int \frac{1}{dr} = \int_{R_1}^{R_2} \frac{t dx}{\rho \pi x}$$

$$\frac{1}{r} = \frac{t}{\pi \rho} \ln \left(\frac{R_2}{R_1} \right)$$

$$\text{Resistance} = \frac{\pi \rho}{t \ln \left(\frac{R_2}{R_1} \right)}$$

$$i = \frac{V_0 t \ln \left(\frac{R_2}{R_1} \right)}{\pi \rho} \quad (\text{A})$$

$(-e\vec{E})$ will be inward direction in order to provide centripetal acceleration. Therefore electric field will be radially outward

$$V_{\text{outer}} < V_{\text{inner}} \quad (\text{C})$$

$$\frac{mV_d^2}{r} = q\vec{E}$$

$$E = \frac{mV_d^2}{qr} \quad (I = neAV_d \Rightarrow V_d \propto i)$$

$$\Delta V = \int \vec{E} \cdot d\vec{r}$$

$$\Delta V \propto V_d^2$$

$$\Delta V \propto I^2$$

6. **Ans. (0.26 TO 0.28)**

$$\text{Sol. } R'_3 = 300 (1 + \alpha \Delta T) = 312 \Omega$$

Now

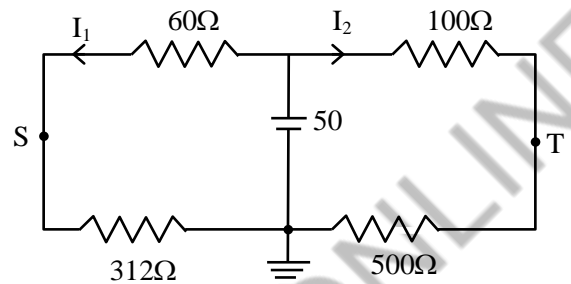

$$I_1 = \frac{50}{372} \text{ and } I_2 = \frac{50}{600}$$

$$V_S - V_T = 312I_1 - 500I_2$$

$$= 41.94 - 41.67$$

$$= 0.27 \text{ V}$$

7. **Ans. (A, C)**

Sol.



$$0.1 = 2 \times 10^{-6} (10 + R_V)$$

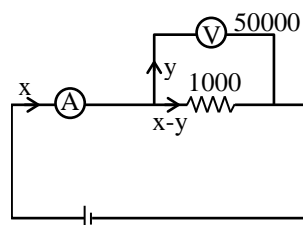

$$\therefore R_V = 49990 \Omega$$

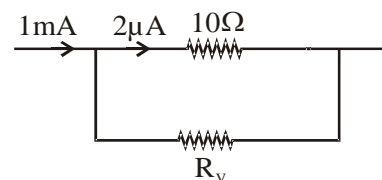

$$2 \times 10^{-6} \times 10 = 10^{-3} R_A \therefore R_A = 0.02 \Omega$$

$$y 50000 = (x - y) 1000$$

$$\therefore 51y = x$$

$$\text{Reading} = \frac{y 50000}{x} \approx 980$$

8. Ans. (C, D)

Sol. Because of non-uniform evaporation at different section, area of cross-section would be different at different sections.

Region of highest evaporation rate would have rapidly reduced area and would become break up cross-section.

Resistance of the wire as whole increases with time.

Overall resistance increases hence power decreases. At break up junction temperature would be highest, thus light of highest band frequency would be emitted at those cross-section.

9. Ans. (B, C)

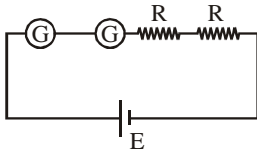

Sol.

$$\text{Range} = i_g(2R_C + 2R)$$

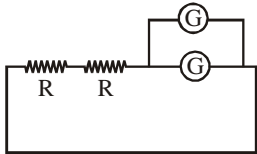

$$\text{Range} = 2i_g \times R_{eq}$$

$$= 2i_g \left(2R + \frac{R_C}{2} \right)$$

$$= i_g(4R + R_C)$$

$$R_C < \frac{R}{2}$$

$$2R_C < R \Rightarrow \text{Range in 1} < 3i_g R$$

$$\text{Range in 2} > 4i_g R$$

So (B)

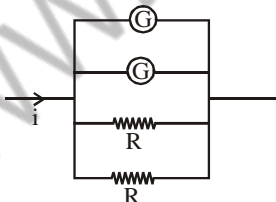

$$\text{Range} = 2i_g + 2i_g \frac{R_C}{R}$$

$$= 2i_g \left(1 + \frac{R_C}{R} \right)$$

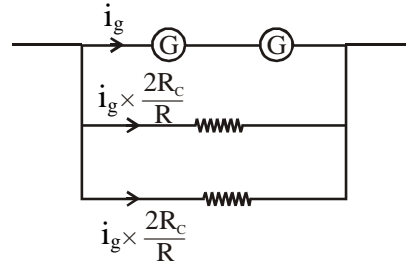

$$\text{Range} = i_g + 4i_g \frac{R_C}{R}$$

$$= 2i_g \left[\frac{1}{2} + \frac{2R_C}{R} \right]$$

$$= 2i_g \left(\frac{1}{2} + \frac{R_C}{R} + \frac{R_C}{R} \right)$$

So (C)

10. Ans. (A)

Sol. Balls placed on +ve plate become positive charge and move upward due to electric field.

These balls on colliding with negative plate become negatively charged and move opposite to the direction of electric field.

11. Ans. (B)

Sol.

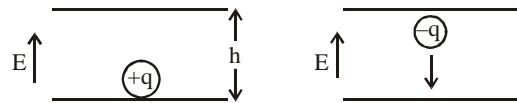

$$h = \frac{1}{2} at^2 \quad [\text{as } u = 0]$$

$$\sqrt{\frac{2hm}{qE}} = \text{time} \Rightarrow \text{time} = \sqrt{\frac{2m}{q\Delta V}}$$

$$E = \frac{V_0}{h}$$

$$\langle \text{current} \rangle = \frac{\text{charge}}{\text{time}} = \frac{q\sqrt{qV_0}}{\sqrt{2mh^2}}$$

$$q \propto V_0$$

$$\langle I \rangle \propto V_0^2$$

12. Ans. (B)

Sol. Aluminium	Ferrous
$A = (7^2 - 2^2) = 45 \text{ mm}^2$	$A = 4 \text{ mm}^2$
$\rho = 2.7 \times 10^{-8} \Omega\text{m}$	$\rho = 10^{-7} \Omega\text{m}$
$\ell = 50 \text{ mm}$	$\ell = 50 \text{ mm}$

$$R_1 = \frac{2.7 \times 10^{-8} \times 50}{45 \times 10^{-3}} \Omega$$

$$R_2 = \frac{10^{-7} \times 50}{4 \times 10^{-3}} \Omega$$

$$R_1 = 30 \mu\Omega$$

$$R_2 = 1250 \mu\Omega$$

$$R_{\text{net}} = \frac{R_1 R_2}{R_1 + R_2} = \frac{30 \times 1250}{1280}$$

$$= \frac{3 \times 125 \times 5}{64}$$

$$R_{\text{net}} = \frac{1875}{64} \mu\Omega$$

13. Ans. (1)

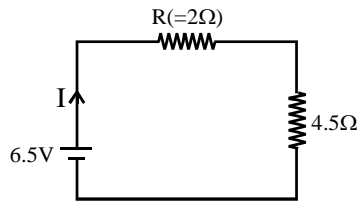
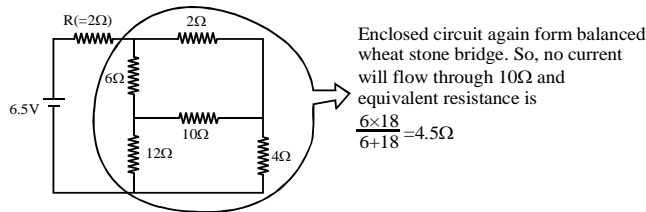
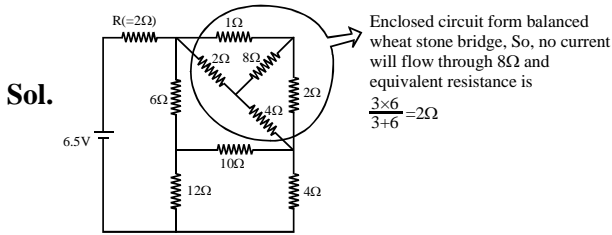

$$\text{Current } I = \frac{6.5V}{6.5\Omega} = 1A$$

14. Ans. (B, D)

Sol. Resistance of heater 1, $R = \frac{4\rho L}{\pi d^2}$

$$\text{Resistance of heater 2, } R_1 = \frac{R}{4}, R_2 = \frac{R}{4}$$

Series $R_{\text{net}} = \frac{R}{2}$

$$\text{Power} = 2 \frac{V^2}{R}$$

\Rightarrow power is twice, hence time is $\frac{1}{2}$

$$\text{time} = \frac{1}{2} \text{ of } 4 \text{ min} = 2 \text{ min}$$

Parallel $R_{\text{Net}} = \frac{R}{8}$

$$\text{Power} = 8 \text{ times}$$

$$\text{time} = \frac{R}{8} \text{ times} = \frac{R}{8} \times 4 \text{ min} = 0.5 \text{ sec}$$

15. Ans. (A, B, D)

Sol. Since current through R_2 is zero

$$\text{Hence } \left[\frac{V_1}{R_1} = \frac{V_2}{R_3} \right]$$

The above equation is satisfied by options

(A, B, D)

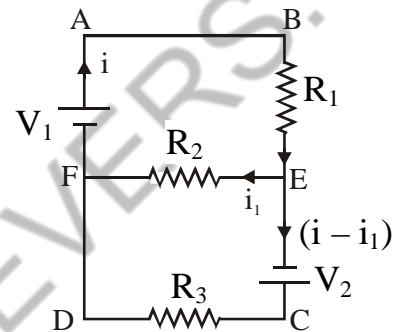

16. Ans. (5)

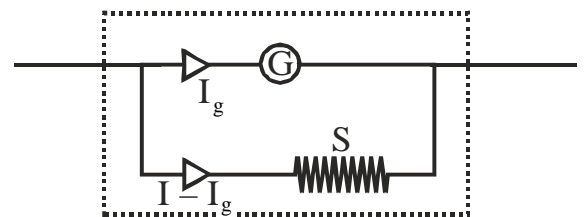
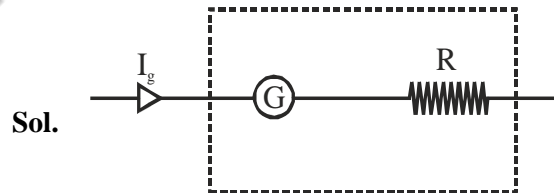

$$V = I_g(R + g)$$

$$30 = 0.006(R + g)$$

$$R + G = 5000$$

$$\Rightarrow G = 10\Omega$$

$$I_g G = (I - I_g)g$$

$$(0.006)(10) = (1.494)(S)$$

$$S = \frac{10}{249}$$

$$\Rightarrow \therefore n = 5$$

17. Ans. (C)

Sol. For meter bridge,

$$R = X \left(\frac{\ell}{100 - \ell} \right)$$

$$= 90 \left(\frac{\ell}{100 - \ell} \right) = 90 \left(\frac{40}{60} \right) = 60 \Omega$$

error in R : (error in = least count)

$$\frac{dR}{R} = \frac{dx}{x} + \frac{d\ell}{\ell} + \frac{d(100 - \ell)}{(100 - \ell)}$$

$$= 0 + \frac{1\text{mm}}{40\text{cm}} + \frac{1\text{mm}}{60\text{cm}}$$

$$\frac{dR}{60\Omega} = \frac{1}{4} \Rightarrow dR = 0.25\Omega$$

$$R = 6 \pm 0.25\Omega$$