

ELECTROSTATICS

1. An electric dipole is formed by two charges $+q$ and $-q$ located in xy -plane at $(0, 2)$ mm and $(0, -2)$ mm, respectively, as shown in the figure. The electric potential at point $P(100, 100)$ mm due to the dipole is V_0 . The charges $+q$ and $-q$ are then moved to the points $(-1, 2)$ mm and $(1, -2)$ mm, respectively. What is the value of electric potential at P due to the new dipole ? **[JEE(Advanced) 2023]**

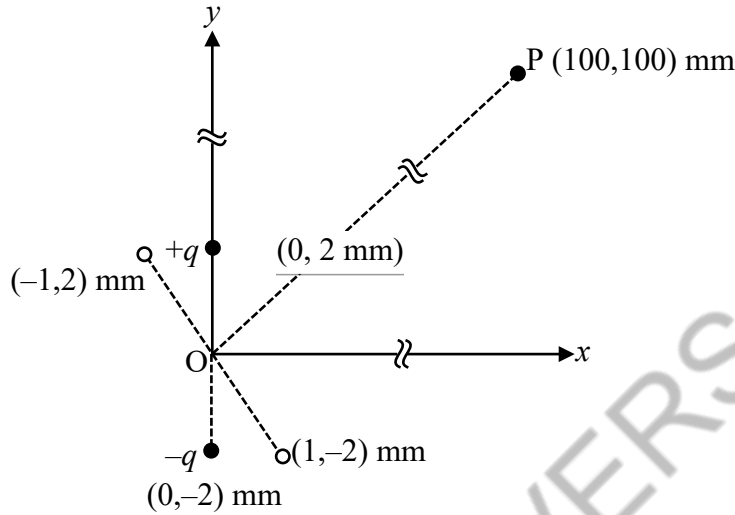

- (A) $V_0/4$ (B) $V_0/2$ (C) $V_0/\sqrt{2}$ (D) $3V_0/4$
2. Six charges are placed around a regular hexagon of side length a as shown in the figure. Five of them have charge q , and the remaining one has charge x . The perpendicular from each charge to the nearest hexagon side passes through the **center** O of the hexagon and is bisected by the side. **[JEE(Advanced) 2022]**

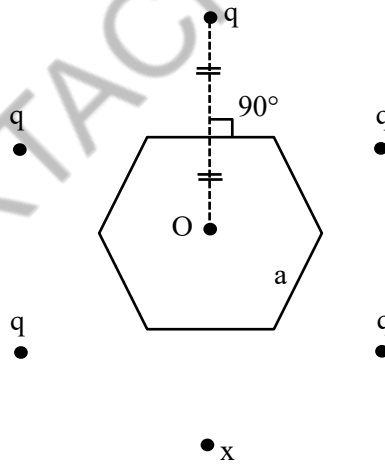

Which of the following statement(s) is(are) correct in SI units?

- (A) When $x = q$, the magnitude of the electric field at O is zero.
- (B) When $x = -q$, the magnitude of the electric field at O is $\frac{q}{6\pi\epsilon_0 a^2}$.
- (C) When $x = 2q$, the potential at O is $\frac{7q}{4\sqrt{3}\pi\epsilon_0 a}$.
- (D) When $x = -3q$, the potential at O is $\frac{3q}{4\sqrt{3}\pi\epsilon_0 a}$.

3. A charge q is surrounded by a closed surface consisting of an inverted cone of height h and base radius R , and a hemisphere of radius R as shown in the figure. The electric flux through the conical surface is $\frac{nq}{6\epsilon_0}$ (in SI units). The value of n is _____.

[JEE(Advanced) 2022]

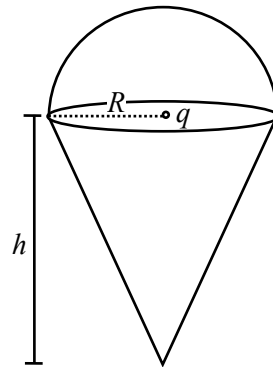

4. In the figure, the inner (shaded) region A represents a sphere of radius $r_A = 1$, within which the electrostatic charge density varies with the radial distance r from the center as $\rho_A = kr$, where k is positive. In the spherical shell B of outer radius r_B , the electrostatic charge density varies as $\rho_B = \frac{2k}{r}$. Assume that dimensions are taken care of. All physical quantities are in their SI units. Which of the following statement(s) is(are) correct?

[JEE(Advanced) 2022]

(A) If $r_B = \sqrt{\frac{3}{2}}$, then the electric field is zero everywhere outside B.

(B) If $r_B = \frac{3}{2}$, then the electric potential just outside B is $\frac{k}{\epsilon_0}$.

(C) If $r_B = 2$, then the total charge of the configuration is $15\pi k$.

(D) If $r_B = \frac{5}{2}$, then the magnitude of the electric field just outside B is $\frac{13\pi k}{\epsilon_0}$.

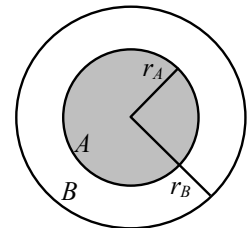

5. A disk of radius R with uniform positive charge density σ is placed on the xy plane with its center at the origin. The Coulomb potential along the z -axis is

$$V(z) = \frac{\sigma}{2\epsilon_0} (\sqrt{R^2 + z^2} - z)$$

A particle of positive charge q is placed initially at rest at a point on the z axis with $z = z_0$ and $z_0 > 0$. In addition to the Coulomb force, the particle experiences a vertical force $\vec{F} = -c\hat{k}$ with $c > 0$.

Let $\beta = \frac{2c\epsilon_0}{q\sigma}$. Which of the following statement(s) is(are) correct?

[JEE(Advanced) 2022]

(A) For $\beta = \frac{1}{4}$ and $z_0 = \frac{25}{7}R$, the particle reaches the origin.

(B) For $\beta = \frac{1}{4}$ and $z_0 = \frac{3}{7}R$, the particle reaches the origin.

(C) For $\beta = \frac{1}{4}$ and $z_0 = \frac{R}{\sqrt{3}}$, the particle returns back to $z = z_0$.

(D) For $\beta > 1$ and $z_0 > 0$, the particle always reaches the origin.

Question Stem for Question Nos. 6 and 7

Question Stem

Two point charges $-Q$ and $+Q/\sqrt{3}$ are placed in the xy -plane at the origin $(0, 0)$ and a point $(2, 0)$, respectively, as shown in the figure. This results in an equipotential circle of radius R and potential $V = 0$ in the xy -plane with its center at $(b, 0)$. All lengths are measured in meters.

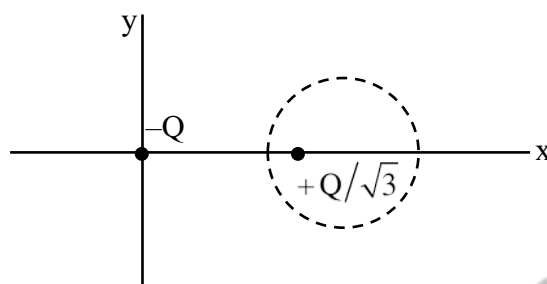

6. The value of R is _____ meter. [JEE(Advanced) 2021]
7. The value of b is _____ meter. [JEE(Advanced) 2021]
8. A uniform electric field, $\vec{E} = -400\sqrt{3}\hat{y} \text{ NC}^{-1}$ is applied in a region. A charged particle of mass m carrying positive charge q is projected in this region with an initial speed of $2\sqrt{10} \times 10^6 \text{ ms}^{-1}$. This particle is aimed to hit a target T , which is 5 m away from its entry point into the field as shown schematically in the figure. Take $\frac{q}{m} = 10^{10} \text{ Ckg}^{-1}$. Then- [JEE(Advanced) 2020]

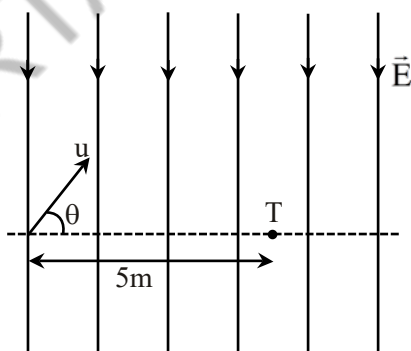

- (A) the particle will hit T if projected at an angle 45° from the horizontal
- (B) the particle will hit T if projected either at an angle 30° or 60° from the horizontal
- (C) time taken by the particle to hit T could be $\sqrt{\frac{5}{6}} \mu\text{s}$ as well as $\sqrt{\frac{5}{2}} \mu\text{s}$
- (D) time taken by the particle to hit T is $\sqrt{\frac{5}{3}} \mu\text{s}$

9. One end of a spring of negligible unstretched length and spring constant k is fixed at the origin $(0,0)$. A point particle of mass m carrying a positive charge q is attached at its other end. The entire system is kept on a smooth horizontal surface. When a point dipole \vec{p} pointing towards the charge q is fixed at the origin, the spring gets stretched to a length ℓ and attains a new equilibrium position (see figure below).

If the point mass is now displaced slightly by $\Delta\ell \ll \ell$ from its equilibrium position and released, it is

found to oscillate at frequency $\frac{1}{\delta} \sqrt{\frac{k}{m}}$. The value of δ is _____.

[JEE(Advanced) 2020]

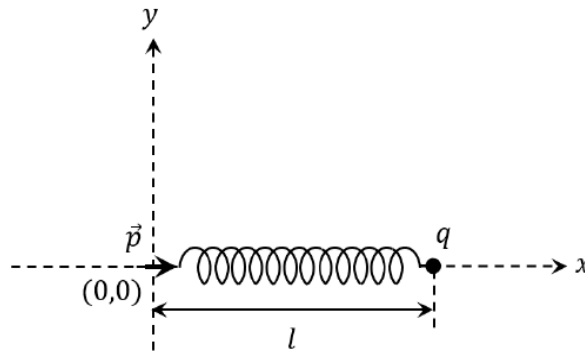

10. A circular disc of radius R carries surface charge density $\sigma(r) = \sigma_0 \left(1 - \frac{r}{R}\right)$, where σ_0 is a constant and r is the distance from the center of the disc. Electric flux through a large spherical surface that encloses the charged disc completely is ϕ_0 . Electric flux through another spherical surface of radius $\frac{R}{4}$ and concentric with the disc is ϕ . Then the ratio $\frac{\phi_0}{\phi}$ is _____.

[JEE(Advanced) 2020]

11. A point charge q of mass m is suspended vertically by a string of length l . A point dipole of dipole moment \vec{p} is now brought towards q from infinity so that the charge moves away. The final equilibrium position of the system including the direction of the dipole, the angles and distances is shown in the figure below. If the work done in bringing the dipole to this position is $N \times (mgh)$, where g is the acceleration due to gravity, then the value of N is _____. (Note that for three coplanar forces keeping a point mass in equilibrium, $\frac{F}{\sin \theta}$ is the same for all forces, where F is any one of the forces and θ is the angle between the other two forces)

[JEE(Advanced) 2020]

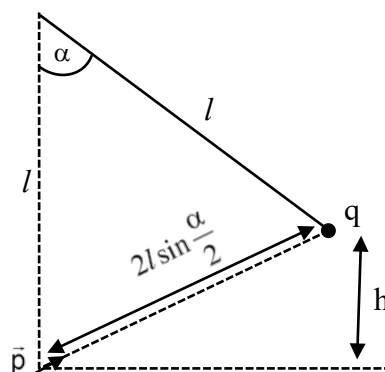

12. Two identical non-conducting solid spheres of same mass and charge are suspended in air from a common point by two non-conducting, massless strings of same length. At equilibrium, the angle between the strings is α . The spheres are now immersed in a dielectric liquid of density 800 kg m^{-3} and dielectric constant 21. If the angle between the strings remains the same after the immersion, then

[JEE(Advanced) 2020]

- (A) electric force between the spheres remains unchanged
 (B) electric force between the spheres reduces
 (C) mass density of the spheres is 840 kg m^{-3}
 (D) the tension in the strings holding the spheres remains unchanged

13. A thin spherical insulating shell of radius R carries a uniformly distributed charge such that the potential at its surface is V_0 . A hole with a small area $\alpha 4\pi R^2$ ($\alpha \ll 1$) is made on the shell without affecting the rest of the shell. Which one of the following statements is correct ?

[JEE(Advanced) 2019]

- (A) The ratio of the potential at the center of the shell to that of the point at $\frac{1}{2}R$ from center towards the

hole will be $\frac{1-\alpha}{1-2\alpha}$

- (B) The magnitude of electric field at the center of the shell is reduced by $\frac{\alpha V_0}{2R}$

- (C) The magnitude of electric field at a point, located on a line passing through the hole and shell's center on a distance $2R$ from the center of the spherical shell will be reduced by $\frac{\alpha V_0}{2R}$

- (D) The potential at the center of the shell is reduced by $2\alpha V_0$

14. A charged shell of radius R carries a total charge Q . Given Φ as the flux of electric field through a closed cylindrical surface of height h , radius r and with its center same as that of the shell. Here, center of the cylinder is a point on the axis of the cylinder which is equidistant from its top and bottom surfaces. Which of the following option(s) is/are correct ? [ϵ_0 is the permittivity of free space]

[JEE(Advanced) 2019]

- (A) If $h > 2R$ and $r > R$ then $\Phi = \frac{Q}{\epsilon_0}$ (B) If $h < \frac{8R}{5}$ and $r = \frac{3R}{5}$ then $\Phi = 0$

- (C) If $h > 2R$ and $r = \frac{4R}{5}$ then $\Phi = \frac{Q}{5\epsilon_0}$ (D) If $h > 2R$ and $r = \frac{3R}{5}$ then $\Phi = \frac{Q}{5\epsilon_0}$

15. An electric dipole with dipole moment $\frac{p_0}{\sqrt{2}}(\hat{i} + \hat{j})$ is held fixed at the origin O in the presence of an uniform electric field of magnitude E_0 . If the potential is constant on a circle of radius R centered at the origin as shown in figure, then the correct statement(s) is/are:

[JEE(Advanced) 2019]

(ϵ_0 is permittivity of free space, $R \gg$ dipole size)

(A) $R = \left(\frac{p_0}{4\pi\epsilon_0 E_0} \right)^{1/3}$

- (B) The magnitude of total electric field on any two points of the circle will be same

(C) Total electric field at point A is $\vec{E}_A = \sqrt{2}E_0(\hat{i} + \hat{j})$

(D) Total electric field at point B is $\vec{E}_B = 0$

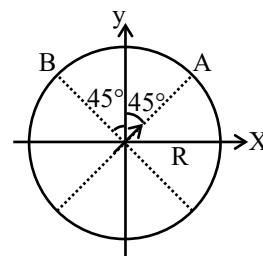

16. An infinitely long thin non-conducting wire is parallel to the z-axis and carries a uniform line charge density λ . It pierces a thin non-conducting spherical shell of radius R in such a way that the arc PQ subtends an angle 120° at the centre O of the spherical shell, as shown in the figure. The permittivity of free space is ϵ_0 . Which of the following statements is (are) true ? **[JEE(Advanced) 2018]**

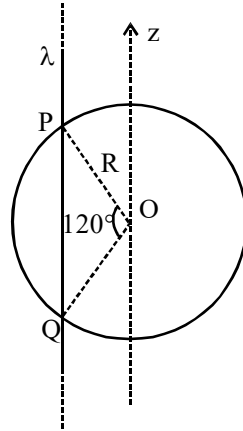

- (A) The electric flux through the shell is $\sqrt{3} R\lambda / \epsilon_0$
 (B) The z-component of the electric field is zero at all the points on the surface of the shell
 (C) The electric flux through the shell is $\sqrt{2} R\lambda / \epsilon_0$
 (D) The electric field is normal to the surface of the shell at all points
17. A particle, of mass 10^{-3} kg and charge 1.0 C, is initially at rest. At time $t = 0$, the particle comes under the influence of an electric field $\vec{E}(t) = E_0 \sin \omega t \hat{i}$ where $E_0 = 1.0 \text{ N C}^{-1}$ and $\omega = 10^3 \text{ rad s}^{-1}$. Consider the effect of only the electrical force on the particle. Then the maximum speed, in ms^{-1} , attained by the particle at subsequent times is _____ **[JEE(Advanced) 2018]**
18. The electric field E is measured at a point P(0,0,d) generated due to various charge distributions and the dependence of E on d is found to be different for different charge distributions. List-I contains different relations between E and d. List-II describes different electric charge distributions, along with their locations. Match the functions in List-I with the related charge distributions in List-II. **[JEE(Advanced) 2018]**

List-I

P. E is independent of d

Q. $E \propto \frac{1}{d}$

R. $E \propto \frac{1}{d^2}$

S. $E \propto \frac{1}{d^3}$

List-II

1. A point charge Q at the origin

2. A small dipole with point charges Q at $(0,0,\ell)$ and $-Q$ at $(0,0,-\ell)$. Take $2\ell \ll d$

3. An infinite line charge coincident with the x-axis, with uniform linear charge density λ .

4. Two infinite wires carrying uniform linear charge density parallel to the x-axis. The one along $(y=0, z=\ell)$ has a charge density $+\lambda$ and the one along $(y=0, z=-\ell)$ has a charge density $-\lambda$. Take $2\ell \ll d$

5. Infinite plane charge coincident with the xy-plane with uniform surface charge density

- (A) P \rightarrow 5 ; Q \rightarrow 3, 4 ; R \rightarrow 1 ; S \rightarrow 2
 (C) P \rightarrow 5 ; Q \rightarrow 3 ; R \rightarrow 1, 2 ; S \rightarrow 4

- (B) P \rightarrow 5 ; Q \rightarrow 3 ; R \rightarrow 1, 4 ; S \rightarrow 2
 (D) P \rightarrow 4 ; Q \rightarrow 2, 3 ; R \rightarrow 1 ; S \rightarrow 5

19. A point charge $+Q$ is placed just outside an imaginary hemispherical surface of radius R as shown in the figure. Which of the following statements is/are correct ? [JEE(Advanced) 2017]

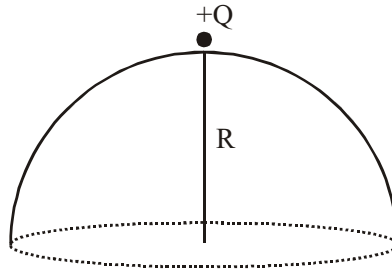

- (A) The circumference of the flat surface is an equipotential
- (B) The electric flux passing through the curved surface of the hemisphere is $-\frac{Q}{2\epsilon_0} \left(1 - \frac{1}{\sqrt{2}}\right)$
- (C) Total flux through the curved and the flat surfaces is $\frac{Q}{\epsilon_0}$
- (D) The component of the electric field normal to the flat surface is constant over the surface.

20. An infinitely long uniform line charge distribution of charge per unit length λ lies parallel to the y -axis in the y - z plane at $z = \frac{\sqrt{3}}{2}a$ (see figure). If the magnitude of the flux of the electric field through the rectangular surface ABCD lying in the x - y plane with its centre at the origin is $\frac{\lambda L}{n\epsilon_0}$ ($\epsilon_0 =$ permittivity of free space) then the value of n is. [JEE(Advanced) 2015]

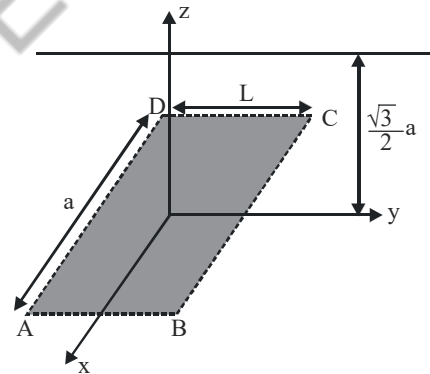

21. The figures below depict two situations in which two infinitely long static line charges of constant positive line charge density λ are kept parallel to each other. In their resulting electric field, point charges q and $-q$ are kept in equilibrium between them. The point charges are confined to move in the x direction only. If they are given a small displacement about their equilibrium positions, then the correct statement(s) is (are) : [JEE(Advanced) 2015]

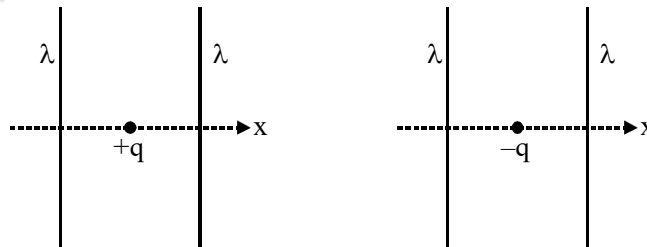

- (A) Both charges execute simple harmonic motion
- (B) Both charges will continue moving in the direction of their displacement
- (C) Charge $+q$ executes simple harmonic motion while charge $-q$ continues moving in the direction of its displacement.
- (D) Charge $-q$ executes simple harmonic motion while charge $+q$ continues moving in the direction of its displacement.

22. Consider a uniform spherical distribution of radius R_1 centred at the origin O . In this distribution, a spherical cavity of radius R_2 , centred at P with distance $OP = a = R_1 - R_2$ (see figure) is made. If the electric field inside the cavity at position \vec{r} is $\vec{E}(\vec{r})$, then the correct statement(s) is(are) :

[JEE(Advanced) 2015]

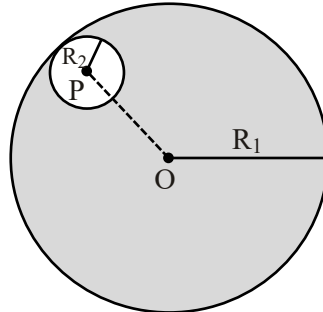

- (A) \vec{E} is uniform, its magnitude is independent of R_2 but its direction depends on \vec{r}
 (B) \vec{E} is uniform, its magnitude depends on R_2 and its direction depends on \vec{r}
 (C) \vec{E} is uniform, its magnitude is independent of a but its direction depends on \vec{a}
 (D) \vec{E} is uniform and both its magnitude and direction depend on \vec{a}
23. Let $E_1(r)$, $E_2(r)$ and $E_3(r)$ be the respective electric fields at a distance r from a point charge Q , an infinitely long wire with constant linear charge density λ , and an infinite plane with uniform surface charge density σ . If $E_1(r_0) = E_2(r_0) = E_3(r_0)$ at a given distance r_0 , then :- [JEE(Advanced) 2014]
- (A) $Q = 4\sigma\pi r_0^2$
 (B) $r_0 = \frac{\lambda}{2\pi\sigma}$
 (C) $E_1(r_0/2) = 2E_2(r_0/2)$
 (D) $E_2(r_0/2) = 4E_3(r_0/2)$
24. Charges Q , $2Q$ and $4Q$ are uniformly distributed in three dielectric solid spheres 1, 2 and 3 of radii $R/2$, R and $2R$ respectively, as shown in figure. If magnitudes of the electric fields at point P at a distance R from the centre of spheres 1, 2 and 3 are E_1 , E_2 and E_3 respectively, then [JEE(Advanced) 2014]

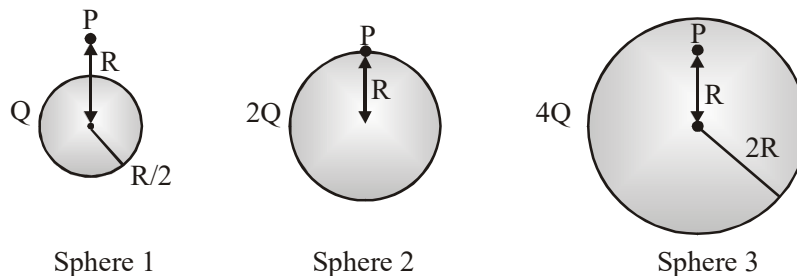

- (A) $E_1 > E_2 > E_3$ (B) $E_3 > E_1 > E_2$
 (C) $E_2 > E_1 > E_3$ (D) $E_3 > E_2 > E_1$

25. Four charges Q_1, Q_2, Q_3 and Q_4 of same magnitude are fixed along the x axis at $x = -2a, -a, +a$ and $+2a$, respectively. A positive charge q is placed on the positive y axis at a distance $b > 0$. Four options of the signs of these charges are given in List-I. The direction of the forces on the charge q is given in List-II. Match List-I with List-II and select the correct answer using the code given below the lists.

[JEE(Advanced) 2014]

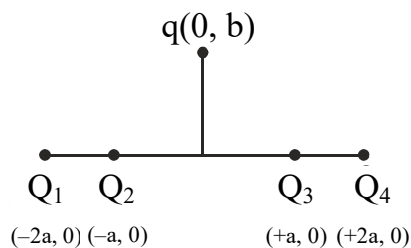

List-I

- (P) Q_1, Q_2, Q_3, Q_4 all positive
 (Q) Q_1, Q_2 positive ; Q_3, Q_4 negative
 (R) Q_1, Q_4 positive ; Q_2, Q_3 negative
 (S) Q_1, Q_3 positive ; Q_2, Q_4 negative

List-II

- (1) $+x$
 (2) $-x$
 (3) $+y$
 (4) $-y$

Code :

- (A) P-3, Q-1, R-4, S-2
 (B) P-4, Q-2, R-3, S-1
 (C) P-3, Q-1, R-2, S-4
 (D) P-4, Q-2, R-1, S-3

SOLUTIONS

1. Ans. (B)

Sol.

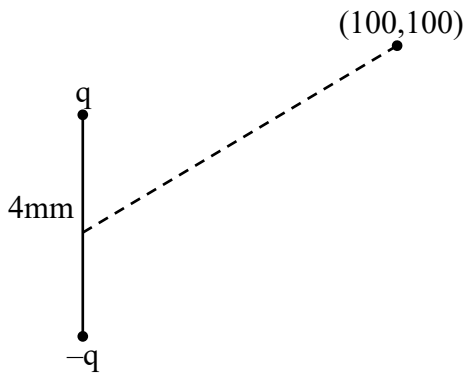

$$P_1 = q(4)$$

$$\vec{P}_1 = P_1 \hat{j}$$

$$\vec{r} = 100(\hat{i} + \hat{j})\text{mm}$$

$$v_0 = \frac{K P_1 \cdot \vec{r}}{r^3} = \frac{K(100 P_1)}{(100\sqrt{2})^3}$$

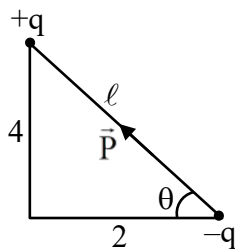

$$\tan \theta = 2$$

$$\vec{P}_2 = P_2 [-\cos \theta \hat{i} + \sin \theta \hat{j}]$$

$$\vec{r} = 100(\hat{i} + \hat{j})\text{mm}$$

$$P_2 = q\ell$$

$$v = \frac{K \vec{P}_2 \cdot \vec{r}}{r^3}$$

$$v = \frac{K(100 P_2) - (-\cos \theta + \sin \theta)}{(100\sqrt{2})^3}$$

$$\frac{v_0 P_2}{P_1} = (-\cos \theta + \sin \theta)$$

$$v = v_0 \frac{q\ell}{q(4)} [-\cos \theta + \sin \theta]$$

$$= \frac{v_0}{4} [-2 + 4] = \frac{v_0}{2}$$

2. Ans. (A, B, C)

Sol. (A) Due to symmetry $\vec{E}_0 = 0$

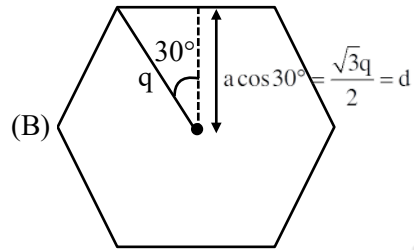

$$E_{\text{net}} = \frac{kq}{(2d)^2} \times 2 = \frac{2q \times 4}{4\pi\epsilon_0 \cdot 4 \cdot 3a^2} = \frac{q}{6\pi\epsilon_0 a^2}$$

$$(C) v = \frac{7kq}{2d} = \frac{7q}{4\pi\epsilon_0 \cdot \sqrt{3}a} = \frac{7q}{4\sqrt{3}\pi\epsilon_0 q}$$

$$(D) v = \frac{2kq}{2d} = \frac{2q}{4\pi\epsilon_0 \cdot \sqrt{3}a} = \frac{q}{2\sqrt{3}\pi\epsilon_0 q}$$

Ans. (A,B,C)

3. Ans. (3)

Sol. From Gauss law,

$$\phi_{\text{hemisphere}} + \phi_{\text{Cone}} = \frac{q}{\epsilon_0} \quad \dots(i)$$

Total flux produced from q in α angle

$$\phi = \frac{q}{2\epsilon_0} [1 - \cos \alpha]$$

$$\text{For hemisphere, } \alpha = \frac{\pi}{2}$$

$$\phi_{\text{hemisphere}} = \frac{q}{2\epsilon_0}$$

From equation (i)

$$= \frac{q}{2\epsilon_0} + \phi_{\text{cone}} = \frac{q}{\epsilon_0}$$

$$\phi_{\text{cone}} = \frac{q}{2\epsilon_0}$$

$$\frac{4q}{6\epsilon_0} = \frac{q}{2\epsilon_0}$$

$$n = 3$$

Alternatively, $\phi \propto$ no of electric field lines passing through surface q is point charge which has uniformly distributed electric field lines thus half of electric field lines will pass through hemisphere & other half will pass through conical surface.

4. **Ans. (B)**

Sol. $q_1 = \int_0^1 kr4\pi r^2 dr = \frac{4\pi k}{4} = \pi k$

$$q_2 = \int_1^r \frac{2k}{r} 4\pi r^2 dr = \frac{8\pi k(r^2 - 1^2)}{2}$$

$$q_2 = 4\pi k[r^2 - 1] = 4\pi kr^2 - 4\pi k$$

$$q_{\text{net}} = q_1 + q_2$$

$$= 4\pi kr^2 - 3\pi k$$

$$q_{\text{net}} = \pi k [4r^2 - 3]$$

(A) $E_{\text{net}} = 0 \Rightarrow q_{\text{net}} = 0 \Rightarrow r = \frac{\sqrt{3}}{2}$

(B) $V = \frac{kQ_{\text{net}}}{r} = \frac{1}{4\pi\epsilon_0} \frac{\pi k(4r^2 - 3)}{r}$

$$V = \frac{k}{4\epsilon_0} \left[4r - \frac{3}{r} \right]$$

$$= \frac{k}{4\epsilon_0} \left[4 \times \frac{3}{2} - \frac{3 \times 2}{3} \right] = \frac{k}{\epsilon_0}$$

(C) $q_{\text{net}} = \pi k [4(2)^2 - 3] = 13\pi k$

(D) $E_2 = \frac{kQ}{r^2}$

$$= \frac{1}{4\pi\epsilon_0} \frac{\pi k(4r^2 - 3)}{r^2}$$

$$= \frac{k}{4\epsilon_0} \left[\frac{4\left(\frac{5}{2}\right)^2 - 3}{\left(\frac{5}{2}\right)^2} \right]$$

$$= \frac{k}{25\epsilon_0} [25 - 3] = \frac{22}{25} \frac{k}{\epsilon_0}$$

5. **Ans. (A, C, D)**

Sol. $W_{\text{el}} + W_{\text{ext}} = k_f - k_i$

$$qv_i - qv_f + W_{\text{ext}} = k_f - k_i$$

$$\frac{q\sigma}{2\epsilon_0} \left[\sqrt{R^2 + Z^2} - Z \right] - \frac{q\sigma R}{2\epsilon_0} + CZ = k_f - 0$$

$$C = \frac{q\sigma B}{2\epsilon_0}$$

Substitute β & Z , calculate kinetic energy at $z = 0$

If kinetic energy is positive, then particle will reach at origin

If kinetic energy is negative, then particle will not reach at origin.

6. **Ans. (1.73)**

7. **Ans. (3.00)**

Sol. Let a point P on circle

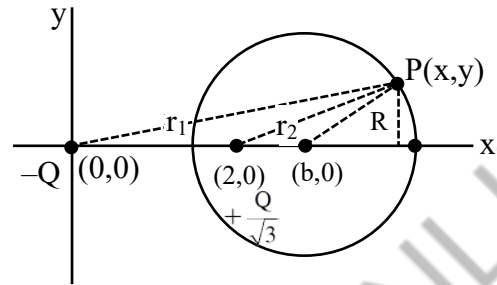

$$V_p = 0 = \frac{k(-Q)}{r_1} + \frac{kQ/\sqrt{3}}{r_2}$$

$$\frac{kQ}{r_1} = \frac{kQ/\sqrt{3}}{r_2}$$

$$\frac{1}{\sqrt{x^2 + y^2}} = \frac{1}{\sqrt{3}\sqrt{(x-2)^2 + y^2}}$$

$$3(x-2)^2 + 3y^2 = x^2 + y^2$$

$$3(x^2 + 4 - 4x) - x^2 + 2y^2 = 0$$

$$2x^2 + 12 - 12x + 2y^2 = 0$$

$$x^2 + 6 - 6x + y^2 = 0$$

$$(x-3)^2 + y^2 = (\sqrt{3})^2$$

$$R = \sqrt{3} = 1.73, \quad b = 3$$

8. **Ans. (B,C)**

Sol. $a_y = -400\sqrt{3} \times 10^{10} [qE_y = ma_y]$

$$R = 5 = \frac{40 \times 10^{12} \sin 2\theta}{400\sqrt{3} \times 10^{10}}$$

$$\left[R(\text{range}) = \frac{u^2 \sin 2\theta}{a_y} \right]$$

$$\sin 2\theta = \frac{\sqrt{3}}{2}$$

$$2\theta = 60^\circ, 120^\circ \Rightarrow \theta = 30^\circ, 60^\circ$$

$$\text{Time of flight } T_1 = \frac{2 \times 2\sqrt{10} \times 10^6 \times \frac{1}{2}}{400\sqrt{3} \times 10^{10}} = \sqrt{\frac{5}{6}} \mu\text{s}$$

(for $\theta = 30^\circ$)

$$\text{Time of flight } T_2 = \frac{2 \times 2\sqrt{10} \times 10^6 \times \frac{\sqrt{3}}{2}}{400\sqrt{3} \times 10^{10}} = \sqrt{\frac{5}{2}} \mu\text{s}$$

(for $\theta = 60^\circ$)

9. Ans. (0.50 OR 3.13 TO 3.15)

Sol. $\Delta l \rightarrow x$

At l : $F_e = F_{\text{Spring}}$

$$kl = \frac{2kpq}{l^3}$$

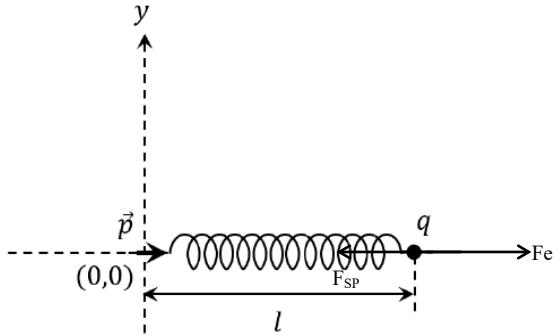

$$F_{\text{net}} = F_{\text{sp}} - F_e = k(\ell + x) - \frac{q(2kp)}{(\ell + x)^3}$$

$$= k(x + \ell) - \frac{q(2kp)}{\ell^3(1 + x/\ell)^3}$$

$$= kx + k\ell - q\left(\frac{2kp}{\ell^3}\right)\left(1 - \frac{3x}{\ell}\right)$$

$$= kx + k\ell - q\left(\frac{2kp}{\ell^3}\right) + \frac{2kpq}{\ell^3} \cdot \frac{3x}{\ell}$$

$$F_N = kx + k\ell \left(\frac{3x}{\ell}\right) = 4kx$$

$$k_{\text{eq}} = 4k$$

$$T = 2\pi\sqrt{\frac{m}{4k}} = \pi\sqrt{\frac{m}{k}}$$

$$f = \frac{1}{\pi}\sqrt{\frac{k}{m}}$$

$$\text{So } \delta = \pi = 3.14$$

10. Ans. (6.40)

Sol.

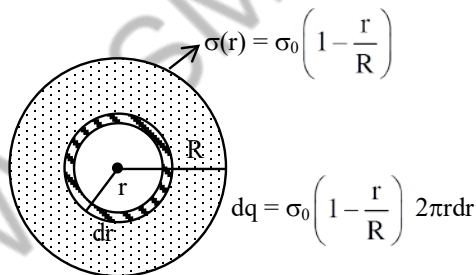

$$\phi_0 = \frac{\int dq}{\epsilon_0} = \frac{\int_0^R \sigma_0 \left(1 - \frac{r}{R}\right) 2\pi r dr}{\epsilon_0}$$

$$\phi = \frac{\int dq}{\epsilon_0} = \frac{\int_0^{R/4} \sigma_0 \left(1 - \frac{r}{R}\right) 2\pi r dr}{\epsilon_0}$$

$$\therefore \frac{\phi_0}{\phi} = \frac{\sigma_0 2\pi \int_0^R \left(r - \frac{r^2}{R}\right) dr}{\sigma_0 2\pi \int_0^{R/4} \left(r - \frac{r^2}{R}\right) dr}$$

$$= \frac{\frac{R^2}{2} - \frac{R^2}{3}}{\frac{R^2}{32} - \frac{R^2}{3 \times 64}} = \frac{32}{5} = 6.40$$

11. Ans. (2)

Sol.

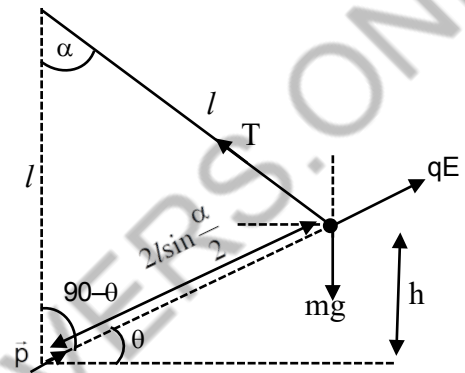

$$U_i = 0$$

$$U_f = \frac{kqP}{\left(2l \sin \frac{\alpha}{2}\right)^2} + mgh \dots (i)$$

Now, from ΔOAB

$$\alpha + 90 - \theta + 90 - \theta = 180 \Rightarrow \alpha = 2\theta$$

$$\text{From } \Delta ABC : h = 2l \sin\left(\frac{\alpha}{2}\right) \sin \theta$$

$$h = 2l \sin\left(\frac{\alpha}{2}\right) \sin\left(\frac{\alpha}{2}\right) \Rightarrow h = 2l \sin^2\left(\frac{\alpha}{2}\right)$$

Now charge is in equilibrium at point B.

So, using sine rule

$$\Rightarrow \frac{mg}{\sin\left[90 + \frac{\alpha}{2}\right]} = \frac{qE}{\sin[180 - 2\theta]}$$

$$\Rightarrow \frac{mg}{\cos \frac{\alpha}{2}} = \frac{qE}{\sin 2\theta}$$

$$\Rightarrow \frac{mg}{\cos \frac{\alpha}{2}} = \frac{qE}{\sin \alpha} \Rightarrow \frac{mg}{\cos \frac{\alpha}{2}} = \frac{qE}{2 \sin \frac{\alpha}{2} \cos \frac{\alpha}{2}}$$

$$\Rightarrow qE = mg 2 \sin\left(\frac{\alpha}{2}\right)$$

$$\Rightarrow \frac{q^2 k p}{\left[2\ell \sin \frac{\alpha}{2}\right]^3} = mg 2 \sin \left(\frac{\alpha}{2}\right)$$

$$\Rightarrow \frac{k p q}{\left[2\ell \sin \frac{\alpha}{2}\right]^2} = mg \sin \left(\frac{\alpha}{2}\right) \times \left(2\ell \sin \frac{\alpha}{2}\right)$$

$$\Rightarrow \frac{k p q}{\left[2\ell \sin \frac{\alpha}{2}\right]^2} = m g h$$

⇒ substituting this in equation (i)

$$U_f = m g h + \frac{k p q}{\left[2\ell \sin \frac{\alpha}{2}\right]^2} \Rightarrow U_f = 2 m g h$$

$$W = \Delta U = N m g h = N = 2$$

12. **Ans. (B, C)**

Sol. The net electric force on any sphere is lesser but by Coulomb law the force due to one sphere to another remain the same.

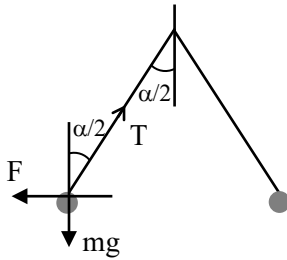

In equilibrium

$$T \cos \frac{\alpha}{2} = m g \text{ and } T \sin \frac{\alpha}{2} = F$$

After immersed in dielectric liquid.

As given no change in angle α .

$$\text{So } T \cos \frac{\alpha}{2} = m g - V \rho g$$

$$\text{when } \rho = 800 \text{ Kg/m}^3 \text{ and } T \sin \frac{\alpha}{2} = \frac{F}{e_r}$$

$$\therefore \frac{m g}{F} = \frac{m g - V \rho g}{\frac{F}{e_r}}$$

$$\frac{1}{e_r} = 1 - \frac{\rho}{d} \quad (d = \text{density of sphere})$$

$$\frac{1}{21} = 1 - \frac{800}{d}$$

$$d = 840$$

13. **Ans. (A)**

Sol. Let charge on the sphere initially be Q .

$$\therefore \frac{k Q}{R} = V_0$$

and charge removed = αQ

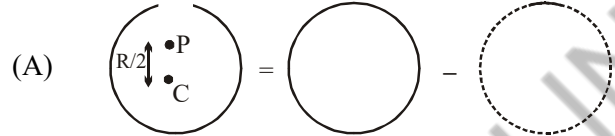

$$\text{and } V_p = \frac{k Q}{R} - \frac{2 K \alpha Q}{R} = \frac{k Q}{R} (1 - 2 \alpha)$$

$$V_C = \frac{k Q (1 - \alpha)}{R}$$

$$\therefore \frac{V_C}{V_p} = \frac{1 - \alpha}{1 - 2 \alpha}$$

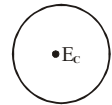

(B) $(E_C)_{\text{initial}} = \text{zero}$

$$(E_C)_{\text{final}} = \frac{k \alpha Q}{R^2}$$

⇒ Electric field increases

(C) $(E_p)_{\text{initial}} = \frac{k Q}{4 R^2}$

$$(E_p)_{\text{final}} = \frac{k Q}{4 R^2} - \frac{k \alpha Q}{R^2}$$

$$\Delta E_p = \frac{k Q}{4 R^2} - \frac{k Q}{4 R^2} + \frac{k \alpha Q}{R^2} = \frac{k \alpha Q}{R^2} = \frac{V_0 \alpha}{R}$$

(D) $(V_C)_{\text{initial}} = \frac{k Q}{R}$

$$(V_C)_{\text{final}} = \frac{k Q (1 - \alpha)}{R}$$

$$\Delta V_C = \frac{k Q}{R} (\alpha) = \alpha V_0$$

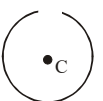
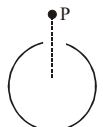
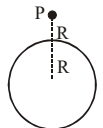

14. **Ans. (A, B, D)**

Sol. For option (A), cylinder encloses the shell, thus option is correct

For option (B)

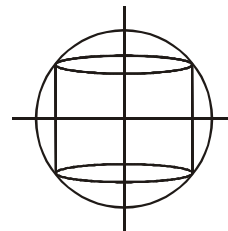

cylinder perfectly enclosed by shell, thus $\phi = 0$, so option is correct.

For option (C)

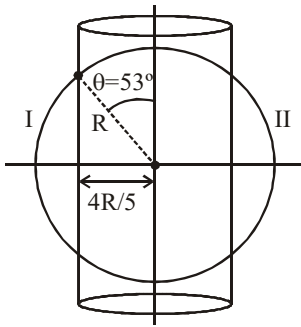

$$\phi = \frac{2 \times Q}{2 \epsilon_0} (1 - \cos 53^\circ) = \frac{2Q}{5 \epsilon_0}$$

For option (D)

Flux enclosed by cylinder

$$= \phi = \frac{2Q}{2 \epsilon_0} (1 - \cos 37^\circ) = \frac{Q}{5 \epsilon_0}$$

15. **Ans. (A, D)**

Sol. (A) $\vec{P} = \frac{P_0}{\sqrt{2}} (\hat{i} + \hat{j})$

E.F. at B along tangent should be zero since circle is equipotential.

So, $E_0 = \frac{K|\vec{P}|}{R^3}$ & $E_B = 0$

So, $R^3 = \frac{KP_0}{E_0} = \left(\frac{P_0}{4\pi \epsilon_0 E_0} \right)$

So, $R = \left(\frac{P_0}{4\pi \epsilon_0 E_0} \right)^{1/3}$

So, (A) is correct

(B) Because E_0 is uniform & due to dipole E.F. is different at different points, so magnitude of total E.F. will also be different at different points.

So, (B) is incorrect

(C) $E_A = \frac{2KP}{R^3} + \frac{KP}{R^3} = 3 \frac{KP}{R^3} \frac{P_0}{\sqrt{2}} (\hat{i} + \hat{j})$

So, (C) is wrong

(D) $E_B = 0$

so, (D) is correct

16. **Ans. (A, B)**

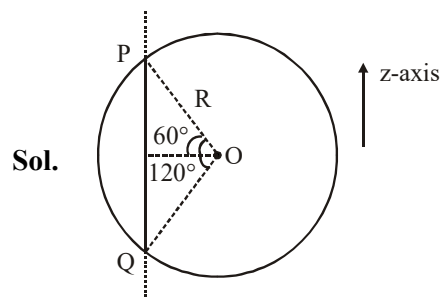

Field due to straight wire is perpendicular to the wire & radially outward. Hence $E_z = 0$

Length, $PQ = 2R \sin 60 = \sqrt{3}R$ According to Gauss's law

$$\text{total flux} = \oint \vec{E} \cdot d\vec{s} = \frac{q_{in}}{\epsilon_0} = \frac{\lambda \sqrt{3}R}{\epsilon_0}$$

17. **Ans. (2.00)**

Sol. $n = 10^{-3} \text{ kg q} = 1C \text{ t} = 0$

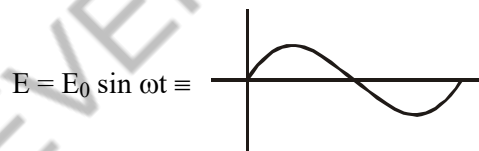

Force on particle will be

$F = qE = qE_0 \sin \omega t$

at v_{max} , $a, F = 0$

$qE_0 \sin \omega t = 0$

$F = qE_0 \sin \omega t$

$\frac{dv}{dt} = q \frac{E_0}{m} \sin \omega t$

$\int_0^v dv = \int_0^{\pi/\omega} \frac{qE_0}{m} \sin \omega t dt$

$v - 0 = \frac{qE_0}{m\omega} [-\cos \omega t]_0^{\pi/\omega}$

$v - 0 = \frac{qE_0}{m\omega} [(-\cos \pi) - (-\cos 0)]$

$v = \frac{1 \times 1}{10^{-3} 10^3} \times 2 = 2 \text{ m/s}$

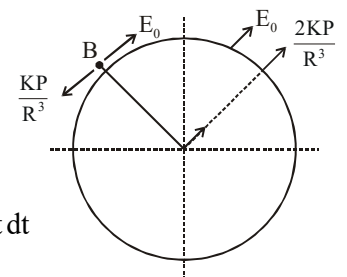

18. **Ans. (B)**

Sol. (i) $E = \frac{KQ}{d^2} \Rightarrow E \propto \frac{1}{d^2}$

(ii) Dipole

$E = \frac{2kp}{d^3} \sqrt{1 + 3 \cos^2 \theta}$

$E \propto \frac{1}{d^3}$ for dipole

(iii) For line charge

$$E = \frac{2k\lambda}{d}$$

$$E \propto \frac{1}{d}$$

$$(iv) E = \frac{2K\lambda}{d-l} - \frac{2K\lambda}{d+l} = 2K\lambda \left[\frac{d+l-d+l}{d^2-l^2} \right]$$

$$E = \frac{2K\lambda(2\ell)}{d^2 \left[1 - \frac{\ell^2}{d^2} \right]}$$

$$E \propto \frac{1}{d^2}$$

(v) Electric field due to sheet

$$E = \frac{\sigma}{2\epsilon_0}$$

$E = v$ is independent of r

19. Ans. (A, B)

Sol. Every point on circumference of flat surface is

at equal distance from point charge

Hence circumference is equipotential.

Flux passing through curved surface

= -flux passing through flat surface.

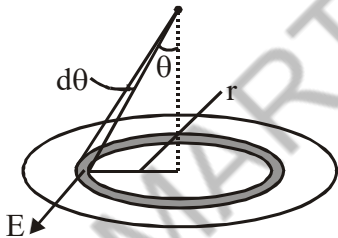

$(d\phi)_{\text{through the ring}} =$

$$E \cos\theta \cdot dA = \frac{1}{4\pi\epsilon_0} \frac{Q}{(\sqrt{r^2 + R^2})^2} \frac{R}{\sqrt{R^2 + r^2}} \cdot 2\pi r dr$$

$$\therefore \int d\phi = \frac{QR}{4\pi\epsilon_0} 2\pi \int_0^R \frac{r dr}{(R^2 + r^2)^{3/2}} = \frac{q}{2\epsilon_0} \left(1 - \frac{1}{\sqrt{2}} \right)$$

$$\therefore \text{Flux through curved surface} = -\frac{q}{2\epsilon_0} \left(1 - \frac{1}{\sqrt{2}} \right)$$

Note : Flux through surface can be calculated using concept of solid angle.

$$\Omega = 2\pi(1 - \cos\theta) = 2\pi \left(1 - \frac{1}{\sqrt{2}} \right)$$

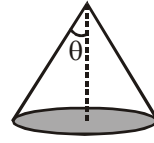

$$\therefore \text{Solid angle subtended} = 2\pi \left(1 - \frac{1}{\sqrt{2}} \right)$$

$$\phi \text{ for } 4\pi \text{ solid angle} = \frac{q}{\epsilon_0}$$

$$\therefore \phi \text{ for } 2\pi \left(1 - \frac{1}{\sqrt{2}} \right) \text{ solid angle}$$

$$= \frac{q}{4\pi\epsilon_0} \cdot 2\pi \left(1 - \frac{1}{\sqrt{2}} \right) = \frac{q}{2\epsilon_0} \left(1 - \frac{1}{\sqrt{2}} \right)$$

20. Ans. (6)

Sol.

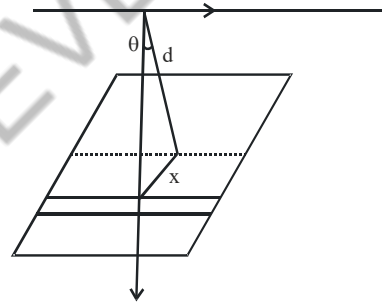

$$d\phi = \frac{\lambda}{2\pi\epsilon_0 \sqrt{d^2 + x^2}} \cdot \frac{d}{\sqrt{d^2 + x^2}} L dx$$

$$\phi = \frac{\lambda d L}{2\pi\epsilon_0} \int_{-a/2}^{a/2} \frac{dx}{d^2 + x^2}$$

$$= \frac{\lambda(d)(L)}{2\pi\epsilon_0} \left(\frac{1}{d} \right) 2 \left[\tan^{-1} \frac{x}{d} \right]_0^{a/2}$$

$$= \frac{\lambda L}{\pi\epsilon_0} \left(\tan^{-1} \frac{a}{2 \cdot \frac{a\sqrt{3}}{2}} \right) = \frac{\lambda L}{6\pi\epsilon_0}$$

21. Ans. (C)

Sol. In first case if q is shifted towards one of the wires, its repulsive force will increase which will bring the charge back.

In second case, in same type of displacement attractive force due to wire increases which will make it move further towards wire.

22. Ans. (D)

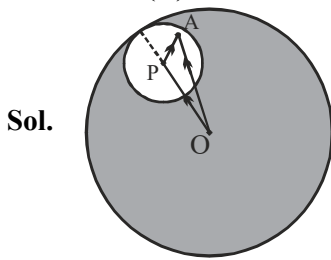

Sol.

Considering any point A inside the cavity electric field can be calculated at A by using super position principle.

$$\vec{E}_A = (\vec{E}_A)_{\text{Due to sphere without cavity}} - (\vec{E}_A)_{\text{Due to sphere of radius } R_2 \text{ \& centre at P}}$$

$$\vec{E}_A = \frac{\rho}{3\epsilon_0} \vec{OA} = \frac{\rho}{3\epsilon_0} (\vec{PA})$$

$$\text{But } \vec{OP} + \vec{PA} = \vec{OA}$$

$$\therefore \vec{OA} - \vec{PA} = \vec{OP}$$

$$\therefore \vec{E}_A = \frac{\rho}{3\epsilon_0} (\vec{OP}) = \frac{\rho}{3\epsilon_0} (\vec{a})$$

So, E.F. is independent of location of A inside the cavity.

23. Ans. (C)

Sol. Point charge

Line charge Infinite sheet

$$E_1(r_0) = \frac{Q}{4\pi\epsilon_0 r_0^2} \quad E_2(r_0) = \frac{\lambda}{2\pi\epsilon_0 r_0}$$

$$E_3(r_0) = \frac{\sigma}{2\epsilon_0}$$

Given, $E_1(r_0) = E_2(r_0) = E_3(r_0)$

$$\frac{Q}{4\pi\epsilon_0 r_0^2} = \frac{\lambda}{2\pi\epsilon_0 r_0} = \frac{\sigma}{2\epsilon_0} \quad \dots(i)$$

$$\text{So, } \frac{Q}{4\pi\epsilon_0 r_0^2} = \frac{\lambda}{2\pi\epsilon_0 r_0} \Rightarrow Q = 2\lambda r_0$$

$$\text{Now, } E_1(r_0/2) = \frac{Q}{4\pi\epsilon_0 \left(\frac{r_0}{2}\right)^2} = \frac{Q}{\pi\epsilon_0 r_0^2}$$

$$= \frac{2\lambda r_0}{\pi\epsilon_0 r_0^2} = \frac{2\lambda}{\pi\epsilon_0 r_0}$$

$$E_2(r_0/2) = \frac{\lambda}{2\pi\epsilon_0 \frac{r_0}{2}} = \frac{\lambda}{\pi\epsilon_0 r_0}$$

$$= \frac{E_1(r_0/2)}{2} \neq 4 E_3$$

From equation (i)

$$\frac{Q}{4\pi\epsilon_0 r_0^2} = \frac{\sigma}{2\epsilon_0} \Rightarrow Q = 2\sigma\pi r_0^2$$

Also from equation (i)

$$\frac{\lambda}{2\pi\epsilon_0 r_0} = \frac{\sigma}{2\epsilon_0} \Rightarrow r_0 = \frac{\lambda}{\sigma\pi}$$

24. Ans. (C)

$$\text{Sol. } E_1 = \frac{KQ}{R^2}$$

$$E_2 = \frac{K(2Q)}{R^2}$$

$$E_3 = \frac{K(4Q)}{(2R)^3} \times R = \frac{KQ}{2R^2}$$

$$E_2 > E_1 > E_3$$

25. Ans. (A)

Sol. When all are positive net field is along +y axis

$$P \rightarrow 3$$

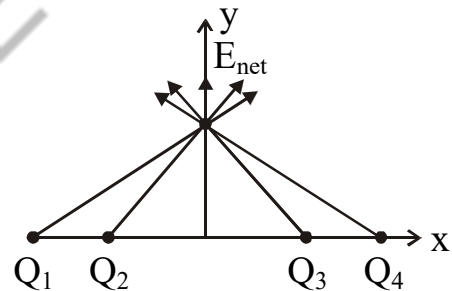

when Q_1, Q_2 positive Q_3, Q_4 negative

$$Q \rightarrow 1$$

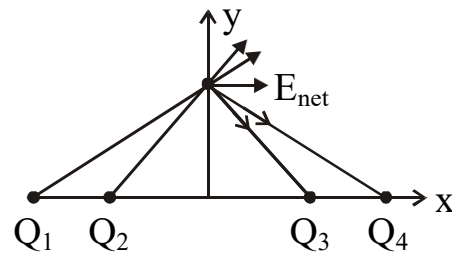

When Q_1, Q_4 positive and Q_2, Q_3 negative

$$R \rightarrow 4$$

