



PRACTICE PAPER 11

CHAPTER 11 DUAL NATURE OF RADIATION AND MATTER

SUBJECT: PHYSICS

MAX. MARKS : 40

CLASS : XII

DURATION : 1½ hrs

General Instructions:

- All questions are compulsory.
- This question paper contains 20 questions divided into five Sections A, B, C, D and E.
- Section A** comprises of 10 MCQs of 1 mark each. **Section B** comprises of 4 questions of 2 marks each. **Section C** comprises of 3 questions of 3 marks each. **Section D** comprises of 1 question of 5 marks each and **Section E** comprises of 2 Case Study Based Questions of 4 marks each.
- There is no overall choice.
- Use of Calculators is not permitted

SECTION – A

Questions 1 to 10 carry 1 mark each.

- The quantum nature of light explains the observations on photoelectric effect as:
 - there is a minimum frequency of incident radiation below which no electrons are emitted.
 - the maximum kinetic energy of photoelectrons depends only on the frequency of incident radiation.
 - when the metal surface is illuminated, electrons are ejected from the surface after sometime.
 - the photoelectric current is independent of the intensity of incident radiation.
- The graph below shows the variation of the maximum kinetic energy of the emitted photoelectron with the frequency of the incident radiation for a given metal.

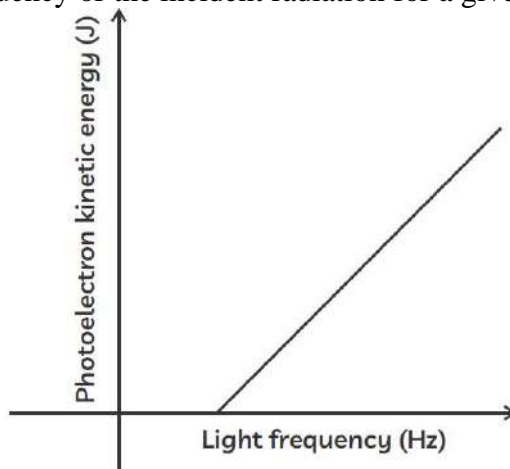

Which of the following gives the work function of the metal?

- (a) x-intercept (b) y-intercept (c) the slope of the graph (d) the area under the graph
- A photon of wavelength 663 nm is incident on a metal surface. The work function of the metal is 1.50 eV. The maximum kinetic energy of the emitted photoelectrons is:
 - 3.0×10^{-20} J
 - 6.0×10^{-20} J
 - 4.5×10^{-20} J
 - 9.0×10^{-20} J
 - The graph showing the correct variation of linear momentum (p) of a charge particle with its de-Broglie wavelength is.

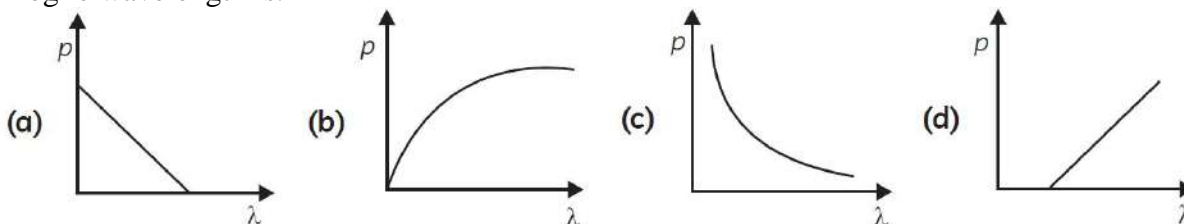

5. A metallic plate exposed to white light emits electrons. For which of the following colours of light, the stopping potential will be maximum?
 (a) Blue (b) Yellow (c) Red (d) Violet
6. The work function for a metal surface is 4.125 eV. The threshold wavelength for this metal surface is:
 (a) 4125 Å (b) 2062.5 Å (c) 3000 Å (d) 6000 Å
7. A photocell connected in an electrical circuit is placed at a distance d from a source of light. As a result, I current flows in the circuit. What will be the current in the circuit when then the distance is reduced to $d/2$?
 (a) I (b) $2I$ (c) $4I$ (d) $I/2$
8. If photons of frequency ν are incident on surfaces of metal A and B of threshold frequencies $\nu/2$ and $\nu/3$ respectively, the ratio of the maximum kinetic energy of electrons emitted from A to that from B is:
 (a) 2 : 3 (b) 3 : 4 (c) 1 : 3 (d) $\sqrt{3} : \sqrt{2}$

In the following questions 9 and 10, a statement of assertion (A) is followed by a statement of reason (R). Mark the correct choice as:

- (a) Both assertion (A) and reason (R) are true and reason (R) is the correct explanation of assertion (A).
 (b) Both assertion (A) and reason (R) are true but reason (R) is not the correct explanation of assertion (A).
 (c) Assertion (A) is true but reason (R) is false.
 (d) Assertion (A) is false but reason (R) is true.

9. Assertion (A): The photoelectrons produced by a monochromatic light beam incident on a metal surface have a spread in their kinetic energies.

Reason (R): The energy of electrons emitted from inside the metal surface, is lost in collision with the other atoms in the metal.

10. Assertion (A): The kinetic energy of photoelectrons emitted by a photosensitive surface depends upon the frequency of incident photon.

Reason (R): The ejection of electrons from metallic surface is possible with frequency of incident photon below the threshold frequency.

SECTION – B

Questions 11 to 14 carry 2 marks each.

11. Define the terms: (a) Threshold frequency, and (b) Stopping potential in photoelectric effect

OR

Write three characteristic features in photoelectric effect which cannot be explained on the basis of wave theory of light, but can be explained only using Einstein's equation.

12. Write Einstein's photoelectric equation. State clearly the three salient features observed in photoelectric effect which can explain on the basis of this equation.

13. The de Broglie wavelengths associated with an electron and a proton are equal. Prove that the kinetic energy of the electron is greater than that of the proton.

14. The given graph shows the variation of photo-electric current (I) with the applied voltage (V) for two different materials and for two different intensities of the incident radiations. Identify and explain using Einstein's photo electric equation for the pair of curves that correspond to (i) different materials but same intensity of incident radiation, (ii) different intensities but same materials.



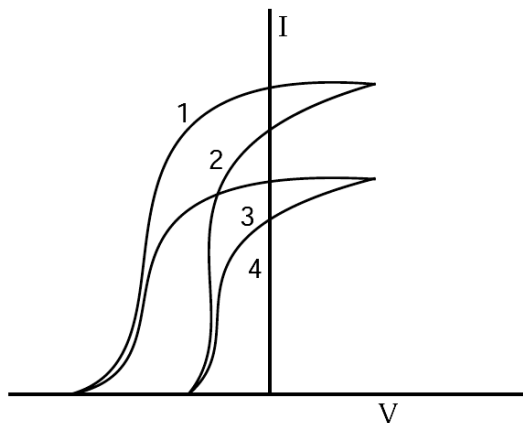

OR

A beam of monochromatic radiation is incident on a photosensitive surface. Answer the following questions giving reasons:

- Do the emitted photoelectrons have the same kinetic energy?
- Does the kinetic energy of the emitted electrons depend on the intensity of incident radiation?
- On what factors does the number of emitted photoelectrons depend?

SECTION – C

Questions 15 to 17 carry 3 marks each.

15. Light of wavelength 2000 \AA falls on a metal surface of work function 4.2 eV .

- What is the kinetic energy (in eV) of the fastest electrons emitted from the surface?
- What will be the change in the energy of the emitted electrons if the intensity of light with same wavelength is doubled?
- If the same light falls on another surface of work function 6.5 eV , what will be the energy of emitted electrons?

OR

- Explain de-Broglie argument to propose his hypothesis. Show that de-Broglie wavelength of photon equals electromagnetic radiation.
- If, deuterons and alpha particle are accelerated through same potential, find the ratio of the associated de-Broglie wavelengths of two.

16. Calculate the wavelength of de Broglie waves associated with a proton having energy. How will the wavelength be affected for an alpha particle having the same energy.

OR

Using photon picture of light, show how Einstein's photoelectric equation can be established. Write two features of photoelectric effect which cannot be explained by wave theory.

17. In the study of a photoelectric effect the graph between the stopping potential V and frequency ' ν ' of the incident radiation on two different metals P and Q is shown below:

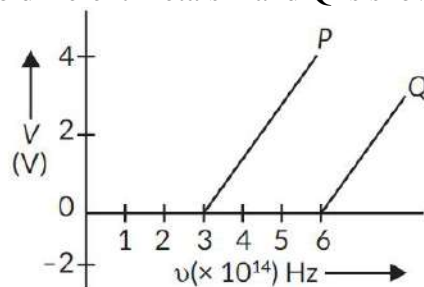

- Which one of the two metals has higher threshold frequency?
- Determine the work function of the metal which has greater value.
- Find the maximum kinetic energy of electron emitted by light of frequency $8 \times 10^{14} \text{ Hz}$ for this metal.

OR

Explain briefly the reasons why wave theory of light is not able to explain the observed features of photo-electric effect.

SECTION – D

Questions 18 carry 5 marks.

18. Derive Einstein's photoelectric equation $\frac{1}{2}mv^2 = hv - hv_0$.

SECTION – E (Case Study Based Questions)

Questions 19 to 20 carry 4 marks each.

19. Figure shows the variation of photoelectric current measured in a photo cell circuit as a function of the potential difference between the plates of the photo cell when light beams A, B, C and D of different wavelengths are incident on the photo cell. Examine the given figure and answer the following questions:

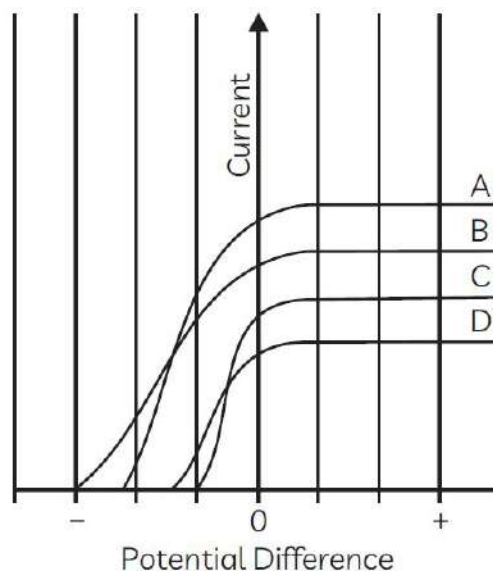

- (i) Which light beam has the highest frequency?
(a) A (b) B (c) C (d) D
- (ii) Which light beam ejects photoelectrons with maximum momentum?
(a) D (b) C (c) B (d) A
- (iii) The stopping potential of a photocell, in which electrons with a maximum kinetic energy of 6 eV are emitted will be
(a) -6V (b) 6V (c) 3V (d) -3V
- (iv) Sodium and copper have work functions 2.3 eV and 4.5 eV respectively. Then the ratio of their threshold wavelengths is nearest to
(a) 1 : 2 (b) 1 : 4 (c) 2 : 1 (d) 4 : 1
20. All these photosensitive substances emit electrons when they are illuminated by light. After the discovery of electrons, these electrons were termed as photoelectrons. The phenomenon is called photoelectric effect.



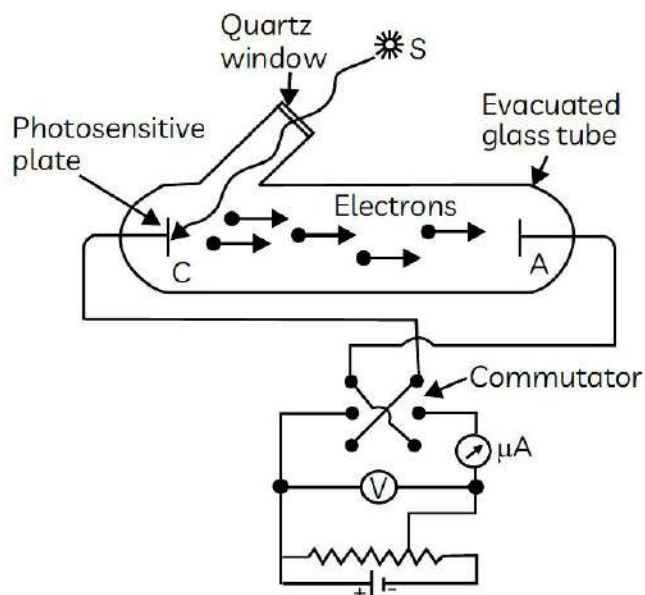

Figure depicts a schematic view of the arrangement used for the experimental study of the photoelectric effect. It consists of an evacuated glass or quartz tube having a thin photosensitive plate C and another metal plate A. Monochromatic light from the source S of sufficiently short wavelength passes through the window W and falls on the photosensitive plate C (emitter). A transparent quartz window is sealed on to the glass tube, which permits ultraviolet radiation to pass through it and irradiate the photosensitive plate C. The electrons are emitted by the plate C and are collected by the plate A (collector), by the electric field created by the battery. The battery maintains the potential difference between the plates C and A, that can be varied. The polarity of the plates C and A can be reversed by a commutator. Thus, the plate A can be maintained at a desired positive or negative potential with respect to emitter C.

- (i) With the increase in the intensity of incident radiation, the:
- (a) Kinetic energy of the emitted photoelectrons increase
 (b) Photoelectric current decreases
 (c) Kinetic energy of the emitted photoelectrons decreases
 (d) Photoelectric current increases
- (ii) The time taken by a photoelectron to come out after the photon strikes is approximately:
- (a) 10^{-4} s (b) 10^{-10} s (c) 10^{-16} s (d) 10^{-1} s
- (iii) In photoelectric effect, the electrons are ejected from metals, if the incident light has a certain minimum:
- (a) amplitude (b) wavelength (c) frequency (d) angle of incidence
- (iv) Photoelectron emission rate is a direct function of radiation:
- (a) frequency (b) speed (c) intensity (d) energy
- OR**
- (v) Consider a beam of electrons (each electron with energy E_0) incident on a metal surface kept in an evacuated chamber. Then:
- (a) no electrons will be emitted as only photons can emit electrons.
 (b) electrons can be emitted but all with an energy, E_0 .
 (c) electrons can be emitted with any energy, with a maximum of $E_0 - \phi$ (ϕ is the work function).
 (d) electrons can be emitted with any energy, with a maximum of E_0 .





PRACTICE PAPER 11

CHAPTER 11 DUAL NATURE OF RADIATION AND MATTER

(ANSWERS)

SUBJECT: PHYSICS

MAX. MARKS : 40

CLASS : XII

DURATION : 1½ hrs

General Instructions:

- All questions are compulsory.
- This question paper contains 20 questions divided into five Sections A, B, C, D and E.
- Section A** comprises of 10 MCQs of 1 mark each. **Section B** comprises of 4 questions of 2 marks each. **Section C** comprises of 3 questions of 3 marks each. **Section D** comprises of 1 question of 5 marks each and **Section E** comprises of 2 Case Study Based Questions of 4 marks each.
- There is no overall choice.
- Use of Calculators is not permitted

SECTION – A

Questions 1 to 10 carry 1 mark each.

1. The quantum nature of light explains the observations on photoelectric effect as:
- there is a minimum frequency of incident radiation below which no electrons are emitted.
 - the maximum kinetic energy of photoelectrons depends only on the frequency of incident radiation.
 - when the metal surface is illuminated, electrons are ejected from the surface after sometime.
 - the photoelectric current is independent of the intensity of incident radiation.

Ans. (a) there is a minimum frequency of incident radiation below which no electrons are emitted.

In photoelectric effect electrons are emitted only for a certain threshold frequency. This is because a minimum energy is required to overcome the work function of the metal. The kinetic energy of ejected electron depends on frequency as well as work function. These observations cannot be explained by the classical theory of light Hence, quantum nature of light is used to explain photoelectric effect.

2. The graph below shows the variation of the maximum kinetic energy of the emitted photoelectron with the frequency of the incident radiation for a given metal.

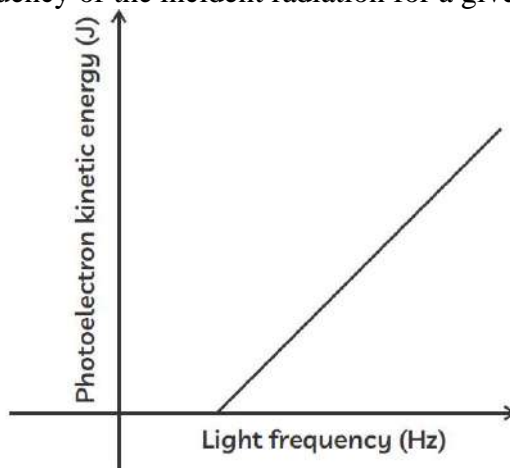

Which of the following gives the work function of the metal?

- (a) x-intercept (b) y-intercept (c) the slope of the graph (d) the area under the graph
- Ans. (b) y-intercept

The work function is minimum energy required for the emission of photoelectron from a surface. The y-intercept gives this energy. Here, x-intercept gives the threshold frequency.

3. A photon of wavelength 663 nm is incident on a metal surface. The work function of the metal is 1.50 eV. The maximum kinetic energy of the emitted photoelectrons is:
- (a) 3.0×10^{-20} J (b) 6.0×10^{-20} J (c) 4.5×10^{-20} J (d) 9.0×10^{-20} J



Ans. (b) $6.0 \times 10^{-20} \text{ J}$

$$\frac{1}{2}mv_{\max}^2 = \frac{hc}{\lambda} - \phi_0 = \frac{6.63 \times 10^{-34} \times 3 \times 10^8}{663 \times 10^{-9}} - 1.50 \times 1.6 \times 10^{-19} = 6 \times 10^{-20} \text{ J}$$

4. The graph showing the correct variation of linear momentum (p) of a charge particle with its de-Broglie wavelength is.

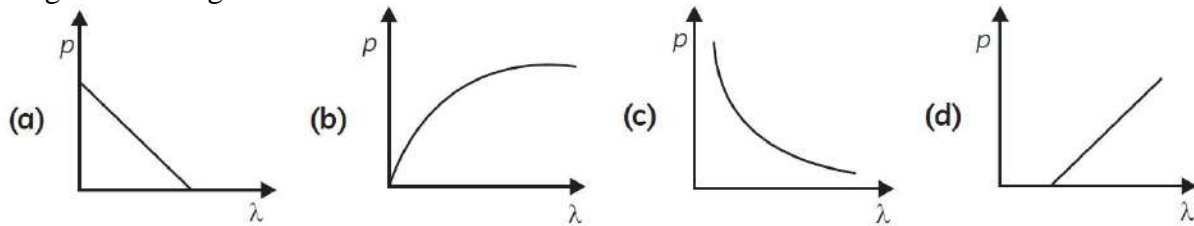

Ans. (c)

The relation between de-Broglie wavelength and the momentum is :

$$\lambda = h/p \Rightarrow p = h/\lambda$$

As $\lambda \propto 1/p$, we get a rectangular hyperbola.

5. A metallic plate exposed to white light emits electrons. For which of the following colours of light, the stopping potential will be maximum?

(a) Blue (b) Yellow (c) Red (d) Violet

Ans. (d) Violet

Higher the frequency, greater is the stopping potential.

6. The work function for a metal surface is 4.125 eV. The threshold wavelength for this metal surface is:

(a) 4125 Å (b) 2062.5 Å (c) 3000 Å (d) 6000 Å

Ans. (c) 3000 Å

7. A photocell connected in an electrical circuit is placed at a distance d from a source of light. As a result, I current flows in the circuit. What will be the current in the circuit when then the distance is reduced to $d/2$?

(a) I (b) $2I$ (c) $4I$ (d) $I/2$

Ans. (c) $4I$

Light intensity is inversely proportional to the square of the distance between a photocell and a light source, and photoelectric current is directly proportional to the intensity of incident light.

If, Intensity $\propto 1/d^2$

and $d' \rightarrow d/2$

Then, new intensity = $4 \times$ Intensity

Hence, current in the circuit becomes, $I' = 4I$

8. If photons of frequency ν are incident on surfaces of metal A and B of threshold frequencies $\nu/2$ and $\nu/3$ respectively, the ratio of the maximum kinetic energy of electrons emitted from A to that from B is:

(a) 2 : 3 (b) 3 : 4 (c) 1 : 3 (d) $\sqrt{3} : \sqrt{2}$

Ans. (b) 3 : 4

In the following questions 9 and 10, a statement of assertion (A) is followed by a statement of reason (R). Mark the correct choice as:

- (a) Both assertion (A) and reason (R) are true and reason (R) is the correct explanation of assertion (A).
(b) Both assertion (A) and reason (R) are true but reason (R) is not the correct explanation of assertion (A).
(c) Assertion (A) is true but reason (R) is false.
(d) Assertion (A) is false but reason (R) is true.

9. **Assertion (A):** The photoelectrons produced by a monochromatic light beam incident on a metal surface have a spread in their kinetic energies.

Reason (R): The energy of electrons emitted from inside the metal surface, is lost in collision with the other atoms in the metal.

Ans. (a) Both Assertion and Reason are true and Reason is the correct explanation of Assertion. Electrons being emitted as photoelectrons have different velocities. Actually all the electrons do not occupy the same level of energy but they occupy continuous band levels. So, electrons being knocked off from different levels come out with different energies. Work function is the energy required to pull the electron out of metal surface. Naturally, electrons on the surface will require less energy to be pulled out hence will have lesser work function as compared with those deep inside the metal.

10. **Assertion (A):** The kinetic energy of photoelectrons emitted by a photosensitive surface depends upon the frequency of incident photon.

Reason (R): The ejection of electrons from metallic surface is possible with frequency of incident photon below the threshold frequency.

Ans. (c) Assertion is true but Reason is false.

According to Einstein equation, $KE = h\nu - h\nu_0$

i.e., KE depends upon the frequency.

Photoelectrons are emitted only if incident frequency is more than the threshold frequency.

SECTION – B

Questions 11 to 14 carry 2 marks each.

11. Define the terms: (a) Threshold frequency, and (b) Stopping potential in photoelectric effect

Ans. (a) Threshold frequency: The minimum frequency of incident light which is just capable of ejecting electrons from a metal is called the threshold frequency. It is denoted by ν_0 .

(b) Stopping potential: The minimum retarding potential applied to anode of a photoelectric tube which is just capable of stopping photoelectric current is called the stopping potential. It is denoted by V_0 .

OR

Write three characteristic features in photoelectric effect which cannot be explained on the basis of wave theory of light, but can be explained only using Einstein's equation.

Ans. The three characteristic features which cannot be explained by wave theory are:

(i) Kinetic energy of emitted electrons is found to be independent of the intensity of incident light.

(ii) There is no emission of electrons if frequency of incident light is below a certain frequency (threshold frequency).

(iii) Photoelectric effect is an instantaneous process.

12. Write Einstein's photoelectric equation. State clearly the three salient features observed in photoelectric effect which can explain on the basis of this equation.

Ans. Einstein's photoelectric equation: $h\nu = h\nu_0 + eV_0$

where ν = incident frequency, ν_0 = threshold frequency, V_0 = stopping potential

(i) Incident energy of photon is used in two ways (a) to liberate electron from the metal surface

(b) rest of the energy appears as maximum energy of electron.

(ii) Only one electron can absorb energy of one photon. Hence increasing intensity increases the number of electrons hence current.

(iii) If incident energy is less than work function, no emission of electron will take place.

(iv) Increasing ν (incident frequency) will increase maximum kinetic energy of electrons but number of electrons emitted will remain same.

13. The de Broglie wavelengths associated with an electron and a proton are equal. Prove that the kinetic energy of the electron is greater than that of the proton.



Ans. As from de Broglie wavelength, $\lambda = \frac{h}{p} = \frac{h}{\sqrt{2mE_k}}$

where E_k = kinetic energy

for equal λ , $E_k \propto \frac{1}{mass}$

mass of electron < mass of proton

\therefore Kinetic Energy of electron is more than kinetic energy of proton

14. The given graph shows the variation of photo-electric current (I) with the applied voltage (V) for two different materials and for two different intensities of the incident radiations. Identify and explain using Einstein's photo electric equation for the pair of curves that correspond to (i) different materials but same intensity of incident radiation, (ii) different intensities but same materials.

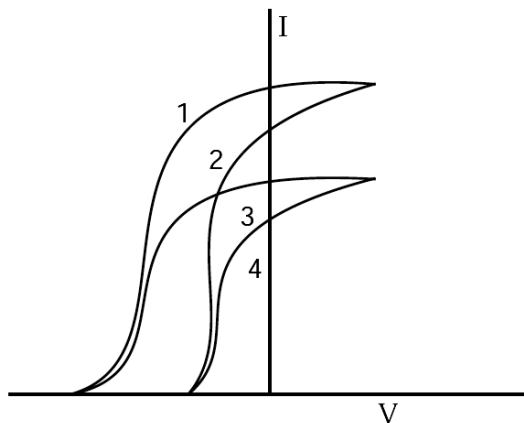

Ans. (i) (a) 1 and 2 correspond to same intensity but different material.

(b) 3 and 4 correspond to same intensity but different material.

This is because the saturation currents are same and stopping potentials are different.

(ii) (a) 1 and 3 correspond to different intensity but same material.

(b) 2 and 4 correspond to different intensity but same material.

This is because the stopping potentials are same but saturation currents are different.

OR

A beam of monochromatic radiation is incident on a photosensitive surface. Answer the following questions giving reasons:

(i) Do the emitted photoelectrons have the same kinetic energy?

(ii) Does the kinetic energy of the emitted electrons depend on the intensity of incident radiation?

(iii) On what factors does the number of emitted photoelectrons depend?

Ans. In photoelectric effect, an electron absorbs a quantum of energy $h\nu$ of radiation, which exceeds the work function, an electron is emitted with maximum kinetic energy,

$$K_{max} = h\nu - W$$

(i) No, all electrons are bound with different forces in different layers of the metal. So, more tightly bound electron will emerge with less kinetic energy. Hence, all electrons do not have same kinetic energy.

(ii) No, because an electron cannot emit out if quantum energy $h\nu$ is less than the work function of the metal. The K.E. depends on energy of each photon.

(iii) Number of emitted photoelectrons depends on the intensity of the radiations provided the quantum energy $h\nu$ is greater than the work function of the metal.

SECTION – C

Questions 15 to 17 carry 3 marks each.

15. Light of wavelength 2000 \AA falls on a metal surface of work function 4.2 eV .

(a) What is the kinetic energy (in eV) of the fastest electrons emitted from the surface?



(b) What will be the change in the energy of the emitted electrons if the intensity of light with same wavelength is doubled?

(c) If the same light falls on another surface of work function 6.5 eV, what will be the energy of emitted electrons?

Ans. (a) Given, $\lambda = 2000 \text{ \AA} = 2000 \times 10^{-10} \text{ m}$

$W_0 = 4.2 \text{ eV}$

$h = 6.63 \times 10^{-34} \text{ J s}$

$$\frac{hc}{\lambda} = W_0 + K.E. \quad \text{or} \quad K.E. = \frac{hc}{\lambda} - W_0$$

$$= \frac{(6.63 \times 10^{-34}) \times (3 \times 10^8)}{(2000 \times 10^{-10})} \times \frac{1}{1.6 \times 10^{-19}} \text{ eV} - 4.2 \text{ eV}$$

$$= (6.2 - 4.2) \text{ eV} = 2.0 \text{ eV}$$

(b) The energy of the emitted electrons does not depend upon intensity of incident light, hence the energy remains unchanged.

OR

(a) Explain de-Broglie argument to propose his hypothesis. Show that de-Broglie wavelength of photon equals electromagnetic radiation.

(b) If, deuterons and alpha particle are accelerated through same potential, find the ratio of the associated de-Broglie wavelengths of two.

Ans. (a) De-broglie reasoned out that nature was symmetrical and two basic physical entities - mass and radiation must be symmetrical. If radiation shows dual aspect than matter should do so.

de-broglie equation, $\lambda = \frac{h}{p}$

For photon, $p = \frac{h\nu}{c}$

Therefore, $\frac{h}{p} = \frac{c}{\nu} = \lambda$, wavelength of electromagnetic radiation.

(b) As $\lambda = \frac{h}{\sqrt{2mK}}$

So, alpha particle will be having shortest De-Broglie wavelength compared to deuterons.

$k = qV$

$$\frac{\lambda_d}{\lambda_\alpha} = \frac{\sqrt{m_\alpha q_\alpha V}}{\sqrt{m_d q_d V}} = \sqrt{\frac{2m_d \times 2q_d}{m_d q_d}} \quad \left(\begin{array}{l} m_\alpha = 2m_d \\ q_\alpha = 2q_d \end{array} \right)$$

$$\frac{\lambda_d}{\lambda_\alpha} = \frac{2}{1} \Rightarrow \lambda_d : \lambda_\alpha = 2 : 1$$

16. Calculate the wavelength of de Broglie waves associated with a proton having energy. How will the wavelength be affected for an alpha particle having the same energy.

Ans.

From the de Broglie wave length, $\lambda_p = \frac{h}{p} = \frac{h}{\sqrt{2m_p KE}}$

Given, KE of proton = $\left(\frac{500}{1.673} \text{ eV} \right) = \frac{500}{1.673} \times 1.6 \times 10^{-19} \text{ J} = 4.78 \times 10^{-17} \text{ J}$

$$\text{Wave length of proton, } \lambda_p = \frac{6.6 \times 10^{-34}}{\sqrt{2 \times 1.67 \times 10^{-27} \times 4.78 \times 10^{-17}}}$$

$$= \frac{6.6 \times 10^{-34}}{4 \times 10^{-22}} = 1.65 \times 10^{-12} \text{ m}$$



For α -particle, $\lambda_{\alpha} = \frac{h}{\sqrt{2m_{\alpha}KE}}$ [K.E = constant (given)]

$$\Rightarrow \frac{\lambda_P}{\lambda_{\alpha}} = \sqrt{\frac{m_{\alpha}}{m_P}} = \sqrt{\frac{4m_P}{m_P}} = 2$$

$$\therefore \lambda_{\alpha} = \frac{1}{2}\lambda_P = \frac{1}{2} \times 1.65 \times 10^{-12} = 0.825 \times 10^{-12} \text{ m}$$

Hence, wavelength for α -particle becomes half of proton's wavelength.

OR

Using photon picture of light, show how Einstein's photoelectric equation can be established. Write two features of photoelectric effect which cannot be explained by wave theory.

Ans. In the photon picture, energy of the light is assumed to be in the form of photons each carrying energy.

When a photon of energy ' $h\nu$ ' falls on a metal surface, the energy of the photon is absorbed by the electrons and is used in the following two ways:

(i) A part of energy is used to overcome the surface barrier and come out of the metal surface.

This part of energy is known as a work function and is expressed as $\phi_0 = h\nu_0$.

(ii) The remaining part of energy is used in giving a velocity ' v ' to the emitted photoelectron

which is equal to the maximum kinetic energy of photo electrons $\left(\frac{1}{2}mv_{\max}^2\right)$

(iii) According to the law of conservation of energy,

$$h\nu = \phi_0 + \frac{1}{2}mv_{\max}^2$$

$$\Rightarrow h\nu = h\nu_0 + \frac{1}{2}mv_{\max}^2 \Rightarrow h\nu = h\nu_0 + KE_{\max}$$

$$\Rightarrow KE_{\max} = h\nu - h\nu_0$$

$$\Rightarrow KE_{\max} = h\nu - \phi_0$$

This equation is called Einstein photoelectric equation.

Features which cannot be explained by wave theory:

(i) The process of photoelectric emission is instantaneous in nature.

(ii) There exists a 'threshold frequency' for each photosensitive material.

(iii) Maximum kinetic energy of emitted electrons is independent of the intensity of incident light.

17. In the study of a photoelectric effect the graph between the stopping potential V and frequency ' ν ' of the incident radiation on two different metals P and Q is shown below:

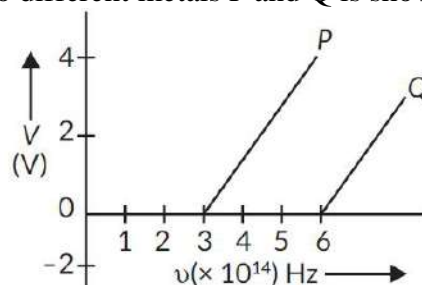

(i) Which one of the two metals has higher threshold frequency?

(ii) Determine the work function of the metal which has greater value.

(iii) Find the maximum kinetic energy of electron emitted by light of frequency 8×10^{14} Hz for this metal.

Ans. (i) Threshold frequency of P is 3×10^{14} Hz.

Threshold frequency of Q is 6×10^{14} Hz.

Clearly Q has higher threshold frequency.



(ii) Work function of metal Q, $\phi_0 = hv_0$

$$= (6.6 \times 10^{-34}) \times 6 \times 10^{14} \text{ J}$$

$$= \frac{39.6 \times 10^{-20}}{1.6 \times 10^{-19}} \text{ eV} = 2.5 \text{ eV}$$

(iii) Maximum kinetic energy, $K_{\max} = hv - hv_0 = h(v - v_0)$

$$= 6.6 \times 10^{-34} (8 \times 10^{14} - 6 \times 10^{14})$$

$$= 6.6 \times 10^{-34} \times 2 \times 10^{14} \text{ J} = \frac{6.6 \times 10^{-34} \times 2 \times 10^{14}}{1.6 \times 10^{-19}} \text{ eV} = 0.83 \text{ eV}$$

$$\therefore K_{\max} = 0.83 \text{ eV}$$

OR

Explain briefly the reasons why wave theory of light is not able to explain the observed features of photo-electric effect.

Ans. The observed characteristics of photoelectric effect could not be explained on the basis of wave theory of light due to the following reasons.

(i) According to wave theory, the light propagates in the form of wavefronts and the energy is distributed uniformly over the wavefronts. With increase of intensity of light, the amplitude of waves and the energy stored by waves will increase. These waves will then, provide more energy to electrons of metal; consequently, the energy of electrons will increase. Thus, according to wave theory, the kinetic energy of photoelectrons must depend on the intensity of incident light; but according to experimental observations, the kinetic energy of photoelectrons does not depend on the intensity of incident light.

(ii) According to wave theory, the light of any frequency can emit electrons from metallic surface provided the intensity of light be sufficient to provide necessary energy for emission of electrons, but according to experimental observations, the light of frequency less than threshold frequency cannot emit electrons; whatever the intensity of incident light may be.

(iii) According to wave theory, the energy transferred by light waves will not go to a particular electron, but it will be distributed uniformly to all electrons present in the illuminated surface. Therefore, electrons will take some time to collect the necessary energy for their emission. The time for emission will be more for light of less intensity and vice versa. But experimental observations show that the emission of electrons take place instantaneously after the light is incident on the metal; whatever the intensity of light may be.

SECTION – D

Questions 18 carry 5 marks.

18. Derive Einstein's photoelectric equation $\frac{1}{2}mv^2 = hv - hv_0$.

Ans. Einstein's Explanation of Photoelectric Effect: Einstein's Photoelectric Equation

Einstein explained photoelectric effect on the basis of quantum theory. The main points are

(i) Light is propagated in the form of bundles of energy. Each bundle of energy is called a quantum or photon and has energy hv where h = Planck's constant and v = frequency of light.

(ii) The photoelectric effect is due to collision of a photon of incident light and a bound electron of the metallic cathode.

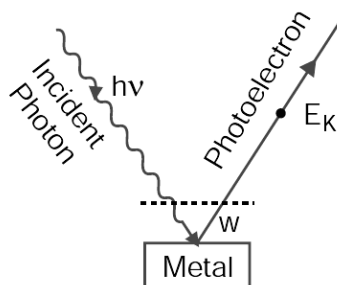

(iii) When a photon of incident light falls on the metallic surface, it is completely absorbed. Before being absorbed it penetrates through a distance of nearly 10^{-8} m (or 100 Å). The absorbed photon transfers its whole energy to a single electron. The energy of photon goes in two parts: a part of energy is used in releasing the electron from the metal surface (i.e., in overcoming work function) and the remaining part appears in the form of kinetic energy of the same electron. If ν be the frequency of incident light, the energy of photon = $h\nu$. If W be the work function of metal and E_K the maximum kinetic energy of photoelectron, then according to Einstein's explanation.

$$h\nu = W + E_K$$

$$\text{or } E_K = h\nu - W \quad \dots(i)$$

This is called Einstein's photoelectric equation.

If ν_0 be the threshold frequency, then if frequency of incident light is less than ν_0 no electron will be emitted and if the frequency of incident light be ν_0 then $E_K = 0$; so from equation (i)

$$0 = h\nu_0 - W \text{ or } W = h\nu_0$$

If λ_0 be the threshold wavelength, then $\nu_0 = \frac{c}{\lambda_0}$

where c is the speed of light in vacuum

$$\therefore \text{Work function } W = h\nu_0 = \frac{hc}{\lambda_0}$$

Substituting this value in equation (i), we get

$$E_K = h\nu - h\nu_0 \Rightarrow \frac{1}{2}mv^2 = h\nu - h\nu_0$$

This is another form of Einstein's photoelectric equation.

SECTION – E (Case Study Based Questions)

Questions 19 to 20 carry 4 marks each.

19. Figure shows the variation of photoelectric current measured in a photo cell circuit as a function of the potential difference between the plates of the photo cell when light beams A, B, C and D of different wavelengths are incident on the photo cell. Examine the given figure and answer the following questions:

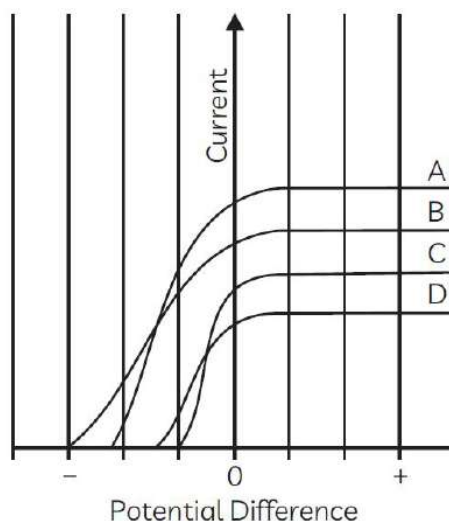

- (i) Which light beam has the highest frequency?
 (a) A (b) B (c) C (d) D
- (ii) Which light beam ejects photoelectrons with maximum momentum?
 (a) D (b) C (c) B (d) A
- (iii) The stopping potential of a photocell, in which electrons with a maximum kinetic energy of 6 eV are emitted will be

- (a) $-6V$ (b) $6V$ (c) $3V$ (d) $-3V$

(iv) Sodium and copper have work functions 2.3 eV and 4.5 eV respectively. Then the ratio of their threshold wavelengths is nearest to

- (a) $1 : 2$ (b) $1 : 4$ (c) $2 : 1$ (d) $4 : 1$

Ans. (i) (b) The light beam B, because it requires maximum retarding potential to reduce the photoelectric current to zero.

(ii) (c) The light beam B ejects photoelectrons with maximum momentum, because highest frequency light beam ejects photoelectrons with highest kinetic energy and hence highest momentum.

(iii) (a) We have, $E_k = eV_0 \Rightarrow 6 \text{ eV} = eV_0 \Rightarrow V_0 = 6 \text{ V}$

The stopping potential $V_0 = 6 \text{ volt}$ (Negative).

(iv) (c) $2 : 1$

$$W_0 = h\nu_0 = \frac{hc}{\lambda_0} \Rightarrow \lambda_0 \propto \frac{1}{W_0}$$

$$\Rightarrow \frac{\lambda_0(\text{Na})}{\lambda_0(\text{Cu})} = \frac{W_0(\text{Cu})}{W_0(\text{Na})} = \frac{4.5}{2.3} = 2$$

$$\therefore \lambda_0(\text{Na}) : \lambda_0(\text{Cu}) = 2 : 1$$

20. All these photosensitive substances emit electrons when they are illuminated by light. After the discovery of electrons, these electrons were termed as photoelectrons. The phenomenon is called photoelectric effect.

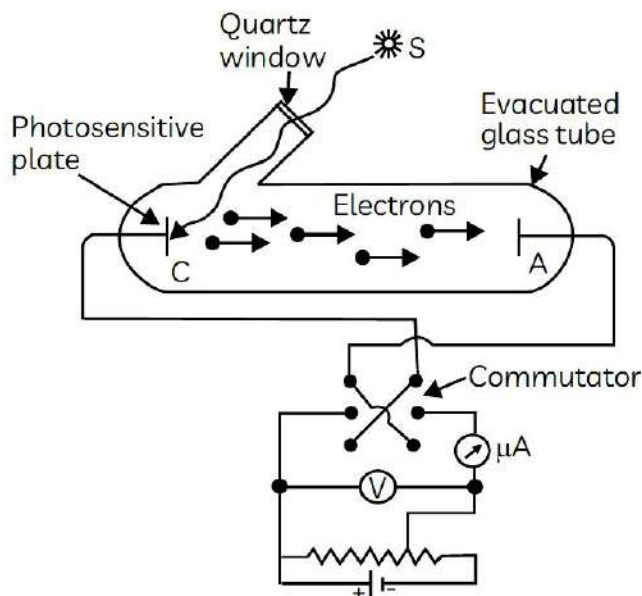

Figure depicts a schematic view of the arrangement used for the experimental study of the photoelectric effect. It consists of an evacuated glass or quartz tube having a thin photosensitive plate C and another metal plate A. Monochromatic light from the source S of sufficiently short wavelength passes through the window W and falls on the photosensitive plate C (emitter). A transparent quartz window is sealed on to the glass tube, which permits ultraviolet radiation to pass through it and irradiate the photosensitive plate C. The electrons are emitted by the plate C and are collected by the plate A (collector), by the electric field created by the battery. The battery maintains the potential difference between the plates C and A, that can be varied. The polarity of the plates C and A can be reversed by a commutator. Thus, the plate A can be maintained at a desired positive or negative potential with respect to emitter C.

- (i) With the increase in the intensity of incident radiation, the:
- (a) Kinetic energy of the emitted photoelectrons increase
- (b) Photoelectric current decreases

- (c) Kinetic energy of the emitted photoelectrons decreases
(d) Photoelectric current increases

(ii) The time taken by a photoelectron to come out after the photon strikes is approximately:

- (a) 10^{-4} s (b) 10^{-10} s (c) 10^{-16} s (d) 10^{-1} s

(iii) In photoelectric effect, the electrons are ejected from metals, if the incident light has a certain minimum:

- (a) amplitude (b) wavelength (c) frequency (d) angle of incidence

(iv) Photoelectron emission rate is a direct function of radiation:

- (a) frequency (b) speed (c) intensity (d) energy

OR

(v) Consider a beam of electrons (each electron with energy E_0) incident on a metal surface kept in an evacuated chamber. Then:

- (a) no electrons will be emitted as only photons can emit electrons.
(b) electrons can be emitted but all with an energy, E_0 .
(c) electrons can be emitted with any energy, with a maximum of $E_0 - \phi$ (ϕ is the work function).
(d) electrons can be emitted with any energy, with a maximum of E_0 .

Ans. (i) (d) Photoelectric current increases

If radiation of a fixed frequency is allowed to fall on the plate and the accelerating potential difference between the two electrodes is kept fixed, then the photoelectric current is found to increase linearly with the intensity of incident radiation.

(ii) (b) 10^{-10} s

The photoelectric effect is an instantaneous phenomenon (experimentally proved). It takes approximate time of the order of 10^{-10} s.

(iii) (c) frequency

For a photosensitive material, there exists a certain minimum cut-off frequency below which no photoelectrons are emitted. This frequency is called threshold frequency.

(iv) (c) intensity

For a given metal and frequency of incident radiation, the rate at which photoelectrons are ejected is directly proportional to the intensity of the incident light.

OR

(v) (d) electrons can be emitted with any energy, with a maximum of E_0 .

The electrons can be emitted with maximum energy E_0 when collision is elastic and with any energy less than E_0 when the part of incident energy of electron is used in liberating the electrons from the surface of metal.

.....

